

SEAL-TITE LT HALF ROUND GUTTER

NON-VERTICAL FASCIA WITH "L" SUPPORT VERSION

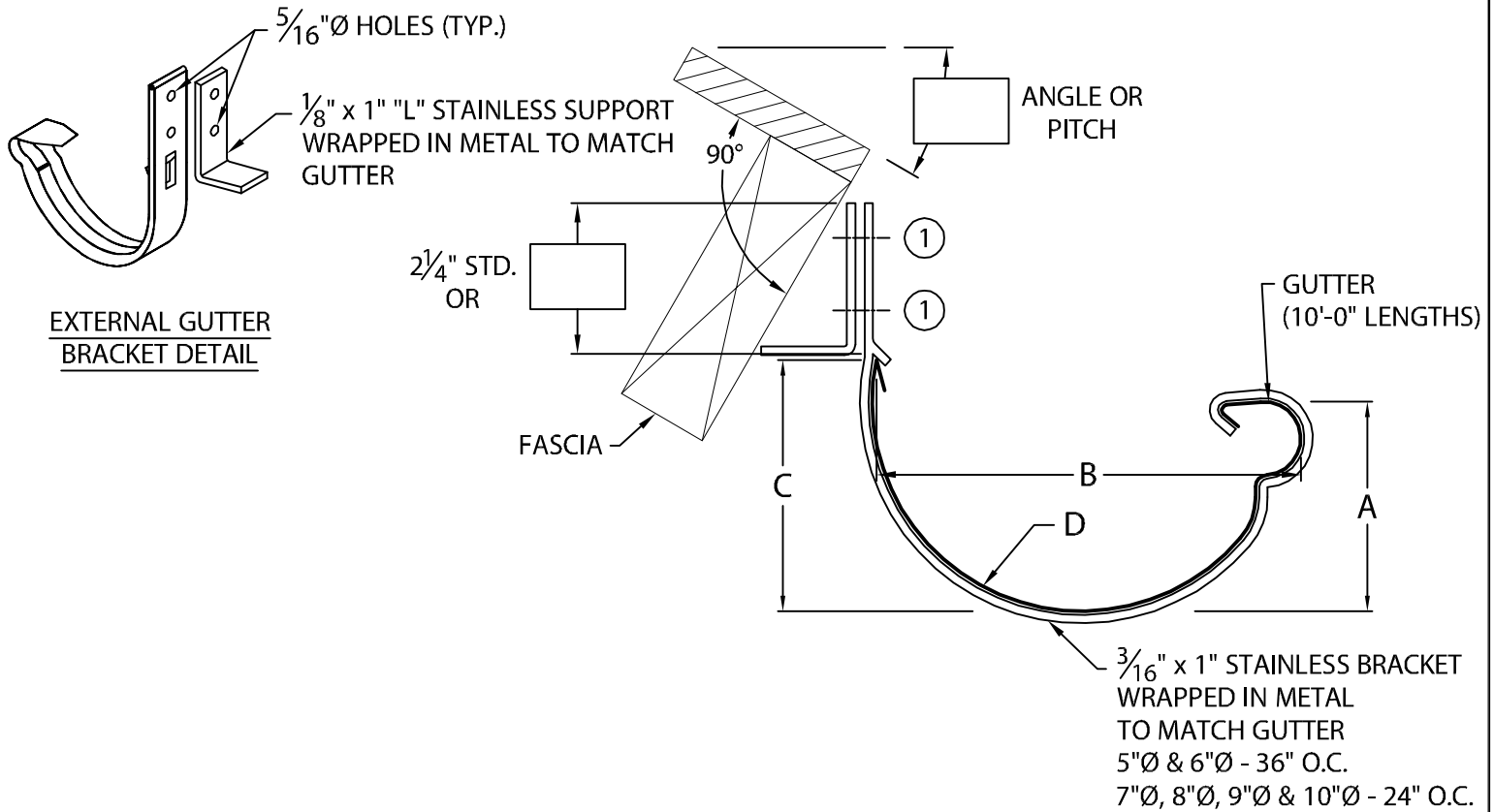

GUTTER DIAMETER	A	B	C	D
<input type="checkbox"/> 5"Ø ②	2½"	5¼"	3"	2½" RADIUS
<input type="checkbox"/> 6"Ø	3"	6¼"	3½"	3" RADIUS
<input type="checkbox"/> 7"Ø	3½"	7¼"	4"	3½" RADIUS
<input type="checkbox"/> 8"Ø	4"	8¼"	4½"	4" RADIUS
<input type="checkbox"/> 9"Ø	4½"	9¼"	5"	4½" RADIUS
<input type="checkbox"/> 10"Ø	5"	10¼"	5½"	5" RADIUS

NOTES:

- MATERIAL PROVIDED WITH 6" WIDE SPLICE PLATES. ④
- MATERIAL NEEDS FIELD NOTCHED LAP JOINTS. ③
- 1/8" STAINLESS STEEL POP RIVETS PROVIDED.
- UNLESS OTHERWISE NOTED, FABRICATION OF MITERS ARE FURNISHED STANDARD UTILIZING POP RIVETS, THEN FACTORY SEALED WATERTIGHT.
- WELDED ACCESSORIES REQUIRE A MINIMUM MATERIAL THICKNESS OF .050".

AUTHORIZED SIGNATURE:

APPROVED BY: _____

DATE:

- ① ROOF PITCH AND "L" SUPPORT SIZE DETERMINE THE TYPE OF FASTENERS PROVIDED
- ② THIS SIZE NOT AVAILABLE IN 22 GA. GALV. STEEL OR .050" ALUM.

MATERIAL:

- ___ 24 GA. GALV. STEEL ③
- ___ 22 GA. GALV. STEEL ② ③
- ___ .032" ALUMINUM ③
- ___ .040" ALUMINUM ③
- ___ .050" ALUMINUM ② ④
- OTHER _____
- COLOR: _____
- FINISH: _____

QUANTITIES:

- _____ LINEAL FEET 10'-0" LENGTHS
- _____ OUTSIDE MITERS @ 90°
- _____ INSIDE MITERS @ 90°
- _____ ENDCAPS: RIGHT _____ LEFT _____
- FOR NON-90 MITERS SEE PRINT APPROVAL #11012-25392

PROJECT: _____

ARCHITECT: _____

ROOFING CONTRACTOR: _____

REPRESENTATIVE/DISTRIBUTOR: _____

Corporate Offices, Manufacturing
 1600 Airport Road; Waukesha, WI 53188
 Phone: 800-558-2162
 Fax: 800-373-9156
 www.metalera.com



DATE: 01/11/17 SHT.# _____ OF _____

DRN BY: JJC

CKD BY: SAK DWG# 11012-25433 **A**