



ELEVATE GOLD COPING

FLAT OR EXISTING SLOPE VERSION - 4'-0" O.C.

INSTALLATION INSTRUCTIONS

IMPORTANT: PRIOR TO INSTALLATION, READ INSTRUCTIONS CAREFULLY.

NOTE: POSITION ROOF MEMBRANE ON TOP OF THE WALL COVERING THE TREATED WOOD NAILER(S) OR SUBSTRATE COMPLETELY. ALLOW 1/2" MINIMUM EXCESS MEMBRANE BEYOND NAILER WHERE APPLICABLE. NRCA REQUIREMENT.

CAUTION: INSTALL MITERS FIRST!

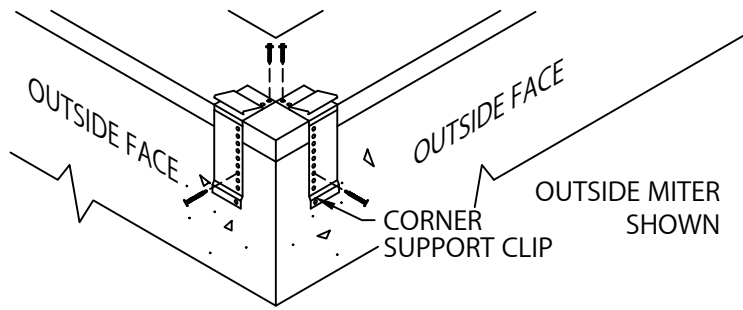

STEP 1 - CORNER SUPPORT CLIPS

LOCATE AND FASTEN GALVANIZED CORNER SUPPORT CLIPS TO THE WALL.

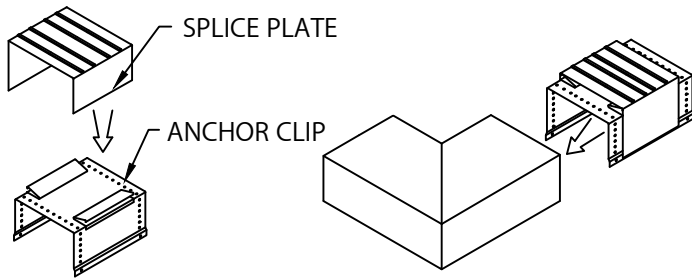

STEP 2 - MITER SPLICE PLATES & ANCHOR CLIPS
POSITION THE SPLICE PLATE IN THE CENTER OF THE ANCHOR CLIP. INSTALL THE SPLICE PLATE AND ANCHOR CLIP ASSEMBLY INTO EACH END OF THE CORNER AS SHOWN

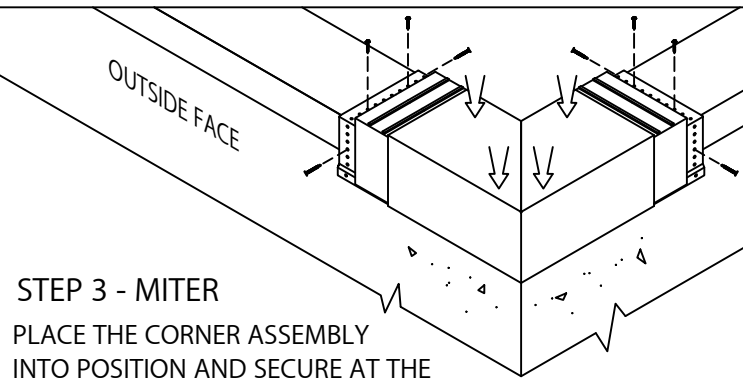

STEP 3 - MITER

PLACE THE CORNER ASSEMBLY INTO POSITION AND SECURE AT THE EXPOSED EDGE OF THE ANCHOR CLIPS AS PER DETAIL A.

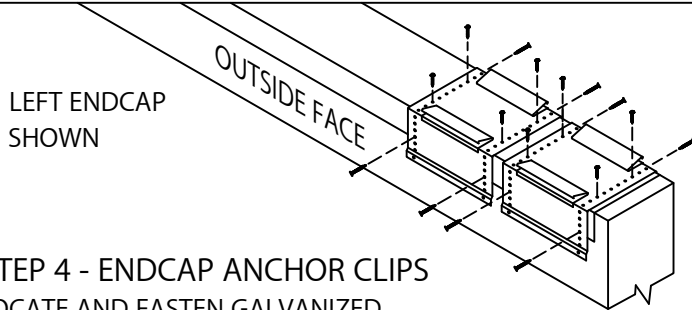

STEP 4 - ENDCAP ANCHOR CLIPS

LOCATE AND FASTEN GALVANIZED ANCHOR CLIPS TO WALL WITH PROVIDED FASTENERS FOR SUBSTRATE (SEE DETAIL A).

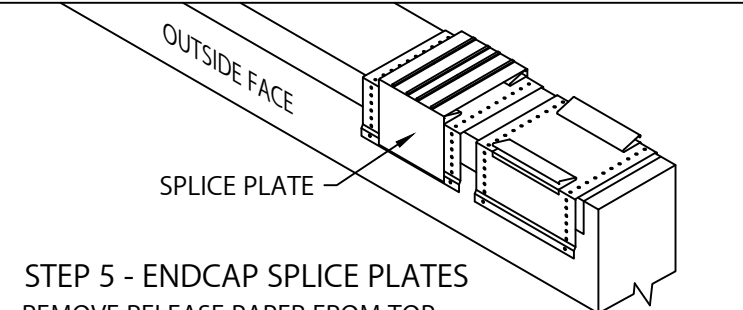

STEP 5 - ENDCAP SPLICE PLATES

REMOVE RELEASE PAPER FROM TOP OF FACTORY APPLIED SEALANT STRIPS. PLACE SPLICE PLATE ONTO SECOND ANCHOR CLIP AS SHOWN.

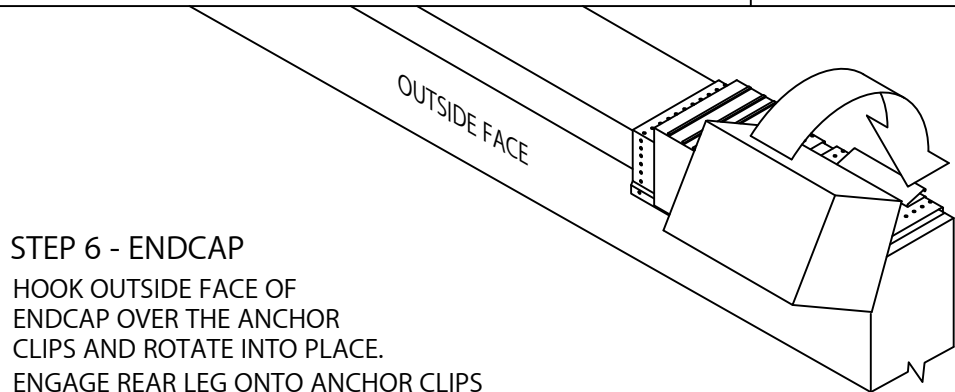

STEP 6 - ENDCAP

HOOK OUTSIDE FACE OF ENDCAP OVER THE ANCHOR CLIPS AND ROTATE INTO PLACE. ENGAGE REAR LEG ONTO ANCHOR CLIPS BY PRESSING DOWNWARD UNTIL SNAP LOCK OCCURS.



ELEVATE
26 CENTURY BLVD.
SUITE 205
NASHVILLE, TN 37214
CONTACT YOUR LOCAL ELEVATE REPRESENTATIVE

DATE: 04/17/23
DRN BY: MLM
CKD BY: MM

SHT.# 1 OF 3
DWG# 13111-38721 **B**



ELEVATE GOLD COPING

FLAT OR EXISTING SLOPE VERSION - 4'-0" O.C.

INSTALLATION INSTRUCTIONS

INSTALLATION NOTES:

- 1) Installing contractor shall check as-built conditions, including nailer attachment, and verify the manufacturer's coping details for accuracy to fit the wall assembly prior to fabrication.
- 2) Fasteners must be corrosion resistant and rated for a minimum 250# pullout force for the substrate that is being used.

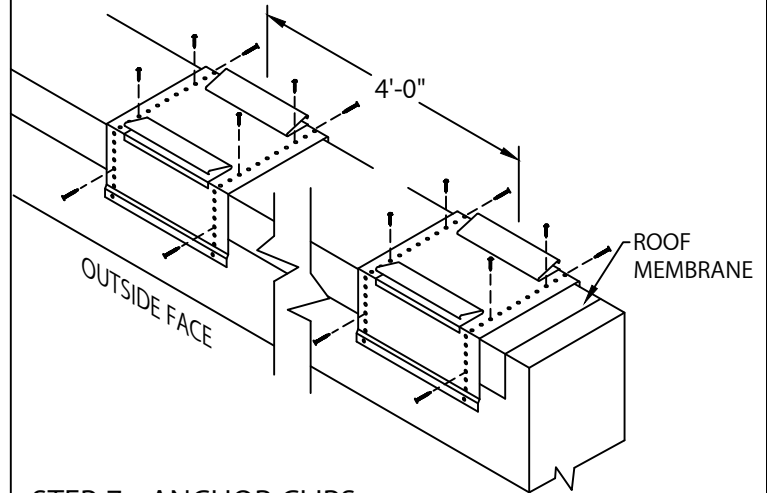
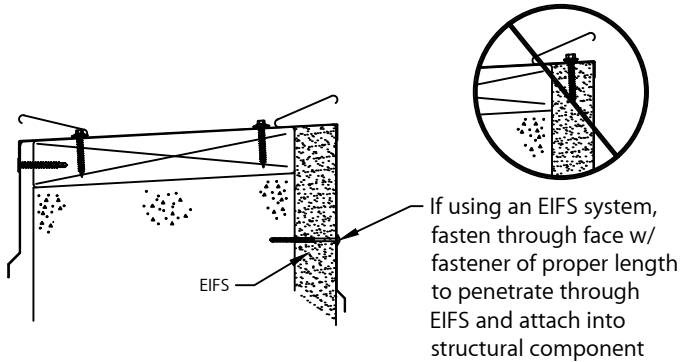

STEP 7 - ANCHOR CLIPS
 LOCATE OVER ROOFING MEMBRANE AND FASTEN GALVANIZED ANCHOR CLIPS TO WALL AT 4'-0" CENTER WITH PROVIDED FASTENERS AS SHOWN IN DETAIL A

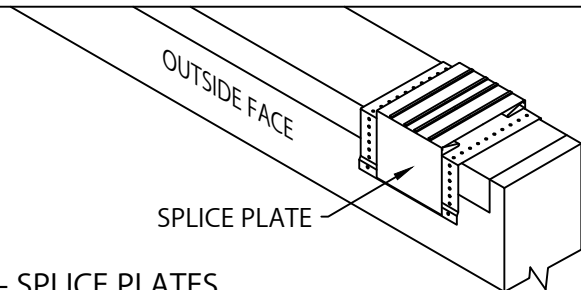

STEP 8 - SPLICE PLATES
 PLACE SPLICE PLATE ONTO ANCHOR CLIPS AT SPLICE JOINTS, 12'-0" O.C.
 NOTE: REMOVE RELEASE PAPER FROM SEALANT STRIPS.

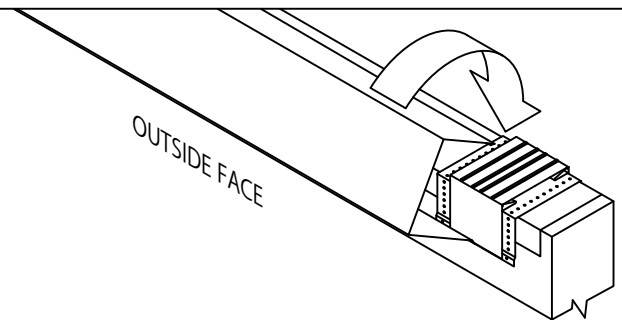

STEP 9 - COPING
 HOOK OUTSIDE FACE OF COPING OVER THE ANCHOR CLIPS AND ROTATE INTO PLACE. ENGAGE REAR LEG ONTO ANCHOR CLIPS BY PRESSING DOWNWARD UNTIL SNAP LOCK OCCURS.

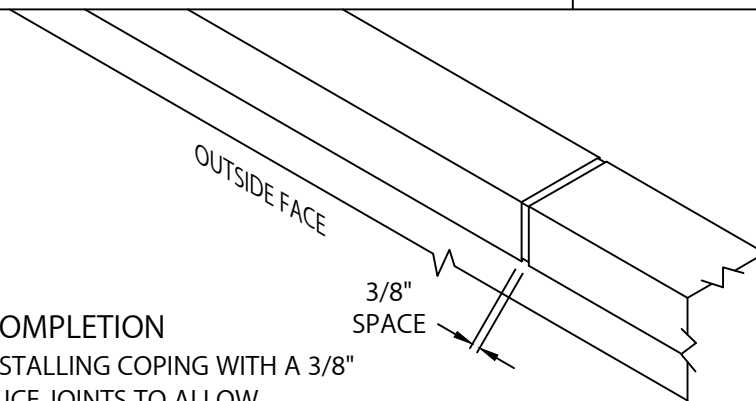

STEP 10 - COMPLETION
 CONTINUE INSTALLING COPING WITH A 3/8" SPACE AT SPLICE JOINTS TO ALLOW FOR THERMAL EXPANSION. FIELD CUT WHERE NECESSARY USING FINE TOOTH HACKSAW OR SNIPS.
 NOTE: REMOVE PROTECTIVE FILM IMMEDIATELY.



ELEVATE
 26 CENTURY BLVD.
 SUITE 205
 NASHVILLE, TN 37214
 CONTACT YOUR LOCAL ELEVATE REPRESENTATIVE

DATE: 04/17/23
 DRN BY: MLM
 CKD BY: MM

SHT.# 2 OF 3
 DWG# 13111-38721 **B**



ELEVATE GOLD COPING

FLAT OR EXISTING SLOPE VERSION - 4'-0" O.C.

INSTALLATION INSTRUCTIONS

TYPICAL COPING INSTALLATION DETAIL A (EXISTING SLOPE VERSION SHOWN)

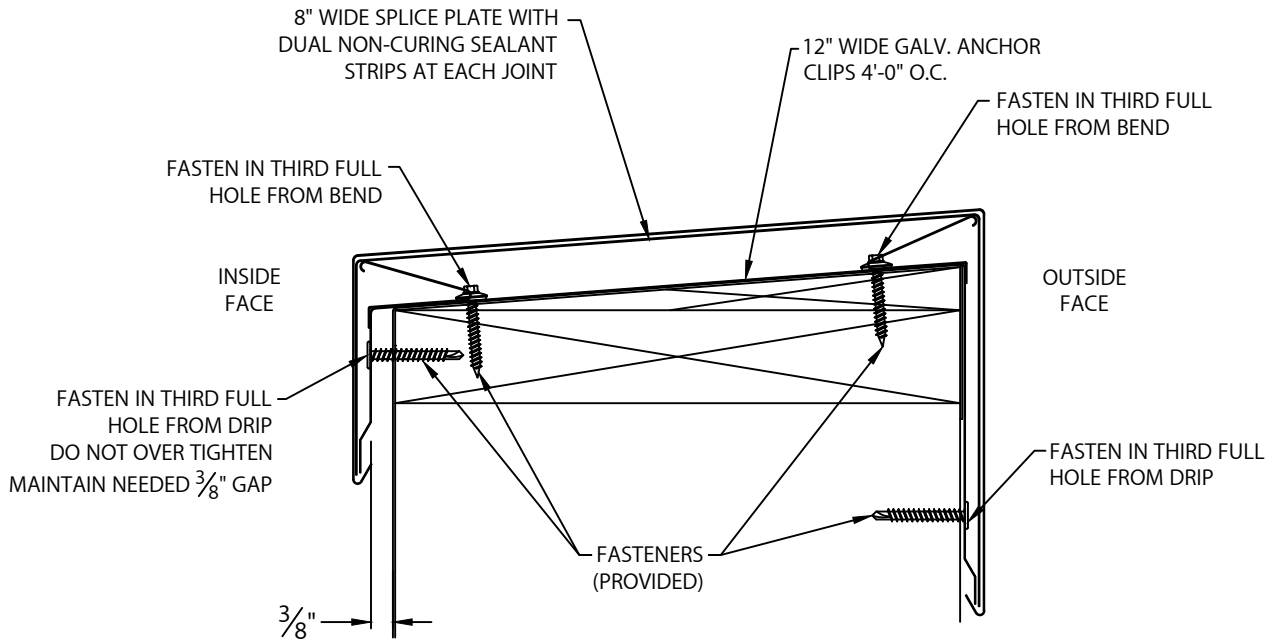

ELEVATE
26 CENTURY BLVD.
SUITE 205
NASHVILLE, TN 37214

CONTACT YOUR LOCAL ELEVATE REPRESENTATIVE

DATE: 04/17/23

DRN BY: MLM

CKD BY: MM

SHT.# 3 OF 3

DWG# 13111-38721

B