

# LG GUTTER

IGG-1 VERSION

WITH WIND STRAPS

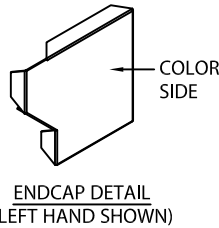
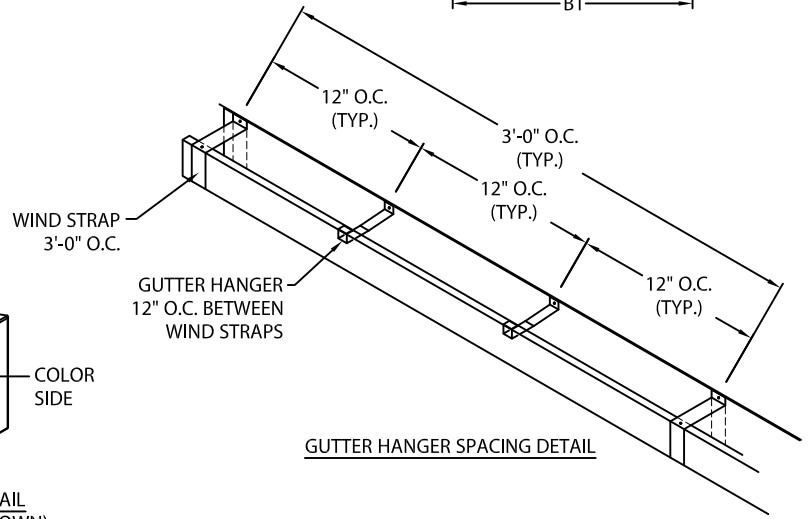
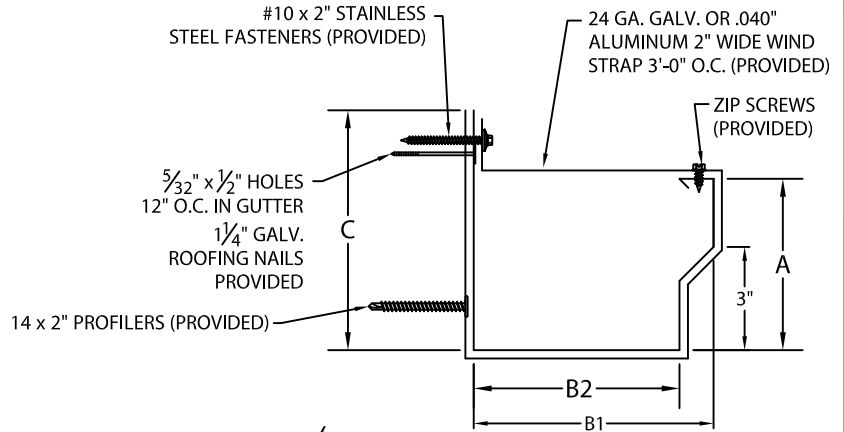
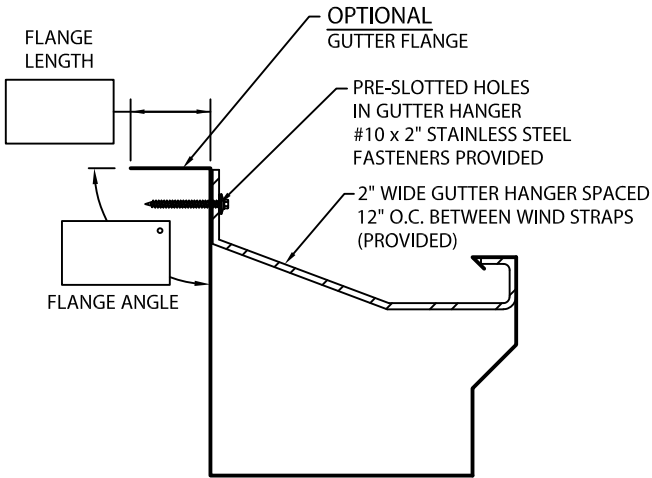

PRODUCT ID #	C	B1	B2	A
<input type="checkbox"/> IGG1-C10	10"	9"	8"	9"
<input type="checkbox"/> IGG1-C11	11"	10"	9"	10"
<input type="checkbox"/> IGG1-C12	12"	11"	10"	11"
<input type="checkbox"/> IGG1-C13	13"	12"	11"	12"

**NOTES:**

- MAXIMUM DOWNSPOUT DIMENSION NOT TO EXCEED "B2" MINUS 9/16".
- 6" WIDE SPLICE PLATES PROVIDED.
- 1/8" STAINLESS STEEL POP RIVETS PROVIDED.
- UNLESS OTHERWISE NOTED, FABRICATION OF MITERS ARE FURNISHED STANDARD UTILIZING A NON-PENETRATING QUICKLOCK JOINT, THEN FACTORY SEALED WATERTIGHT.
- WELDED ACCESSORIES REQUIRE A MINIMUM MATERIAL THICKNESS OF .050".

Fabrication will proceed only after receipt of signed print approval.

**Print Approval:**

Architect and/or contractor shall verify all dimensions, sizes and quantities. All products to be installed in strict accordance with Metal-Era's printed instructions.

Approved by: \_\_\_\_\_

Date: \_\_\_\_\_

**MATERIAL:**

- \_\_\_ 22 GA. GALV. STEEL
- \_\_\_ .050" ALUMINUM
- \_\_\_ .063" ALUMINUM
- \_\_\_ OTHER \_\_\_\_\_

(NOT AVAILABLE IN 24 GA. GALV. STEEL OR .040" ALUMINUM)

COLOR: \_\_\_\_\_ FINISH: \_\_\_\_\_

**QUANTITIES:**

- \_\_\_ LINEAL FEET 12'-0" LENGTHS
- \_\_\_ OUTSIDE MITERS @ 90°
- \_\_\_ INSIDE MITERS @ 90°
- \_\_\_ RIGHT ENDCAPS
- \_\_\_ LEFT ENDCAPS
- \_\_\_ EXPANSION JOINTS STYLE "1"
- \_\_\_ EXPANSION JOINTS STYLE "2"

- SPECIFY MITER TYPE:
- WELDED
  - QUICKLOCK

FOR NON-90 MITERS SEE PRINT APPROVAL #11012-10010

**PROJECT:**

**ARCHITECT:**

**ROOFING CONTRACTOR:**

**REPRESENTATIVE/DISTRIBUTOR:**

Corporate Offices, Manufacturing  
1600 Airport Road; Waukesha, WI 53188  
Phone: 800-558-2162  
Fax: 800-373-9156  
www.metalera.com



DATE: 10/04/21

DRN BY: JJC

CKD BY: MM

SHT.# \_\_\_\_ OF \_\_\_\_

DWG# 11012-37208

A