

# **\*PLEASE READ\***

## **TECH BULLETIN: “PINKING” OF TPO PRODUCTS**

You may notice a pink, red or orangish coloration called "pinking" on the surface of TPO products and samples. Please note that this is a **temporary** coloration. The “pinking” **will** go away within 24 hours of being installed once it is exposed to UV light. It’s important that the product is **installed** and **exposed completely** for the UV light to reach the full product.

Many TPO products contain a stabilization/weathering package which includes very powerful antioxidants that help protect the finished product from degradation due to heat induced thermal oxidation and sunlight induced photo-oxidation. Certain antioxidants in some weathering packages are particularly effective, but they are susceptible to pinking under the right environmental conditions, usually during storage. Pinking or "gas fading" is a surface reaction of these antioxidants with air pollutants, mostly nitrous oxides and sulfur oxides, produced in combustion processes. Pinking occurs over time on unweathered TPO surfaces that are exposed to polluted air, particularly in the absence of light.

As mentioned this is a temporary condition. The pinking will disappear upon exposure to sunlight and weathering in general once the product is completely installed. The products are not stained or permanently discolored in any way.



# GENFLEX TPO SKIRTED DRIP EDGE

TPO VERSION WITH FACTORY APPLIED TPO FLASHING WITH CONTINUOUS CLEAT

NOTE: INSTALL MITERS FIRST

INSTALLATION INSTRUCTIONS

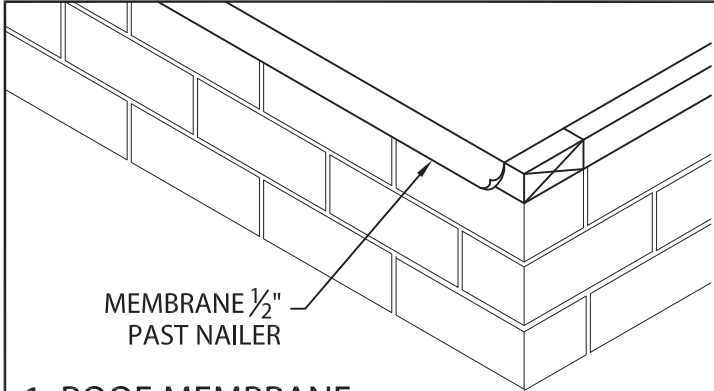

MEMBRANE 1/2" PAST NAILER

## 1. ROOF MEMBRANE

POSITION MEMBRANE OVER THE ROOF EDGE AND DOWN OUTSIDE FACE OF WALL, COVERING WOOD NAILER(S) COMPLETELY. ALLOW 1/2" EXCESS MEMBRANE.

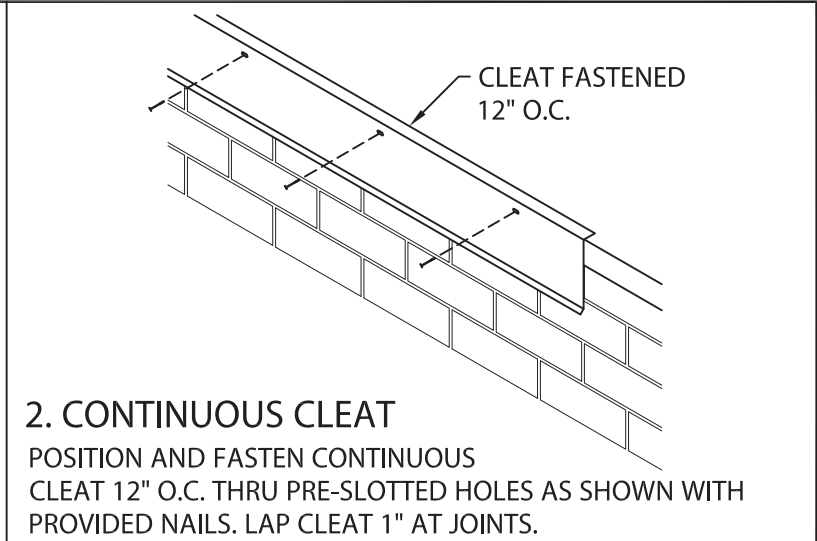

CLEAT FASTENED 12" O.C.

## 2. CONTINUOUS CLEAT

POSITION AND FASTEN CONTINUOUS CLEAT 12" O.C. THRU PRE-SLOTTED HOLES AS SHOWN WITH PROVIDED NAILS. LAP CLEAT 1" AT JOINTS.

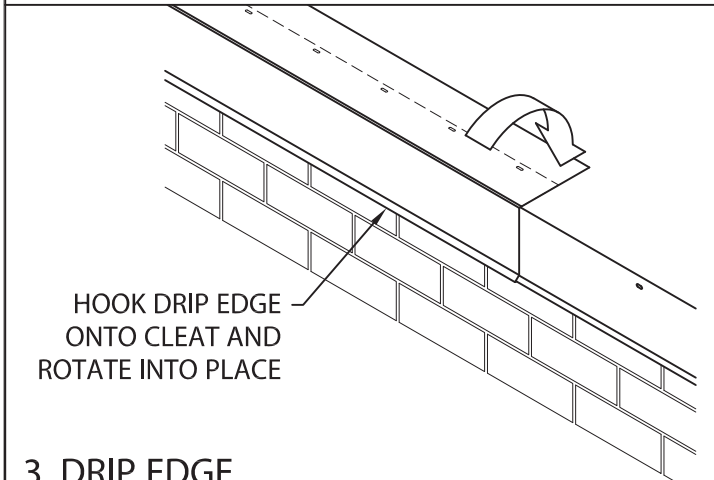

HOOK DRIP EDGE ONTO CLEAT AND ROTATE INTO PLACE

## 3. DRIP EDGE

HOOK DRIP EDGE OF EACH DRIP EDGE SECTION ONTO CONTINUOUS CLEAT, ROTATE INTO PLACE.

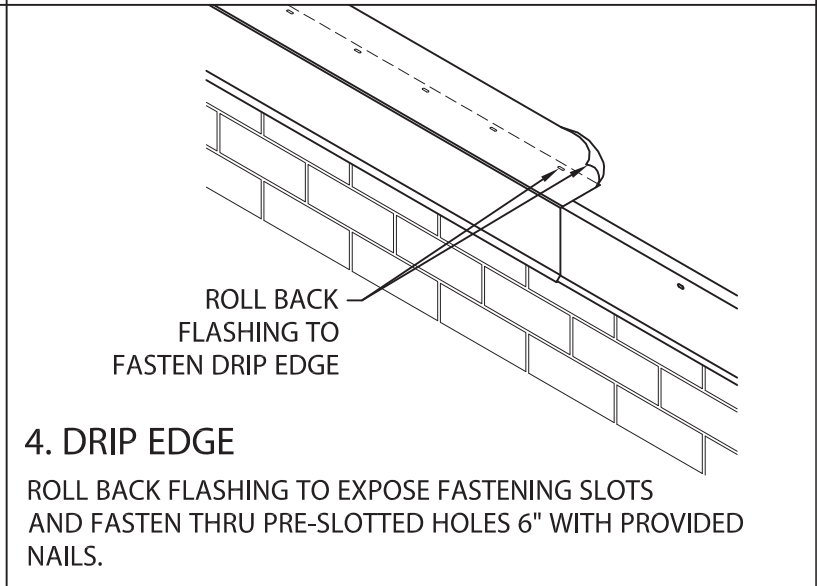

ROLL BACK FLASHING TO FASTEN DRIP EDGE

## 4. DRIP EDGE

ROLL BACK FLASHING TO EXPOSE FASTENING SLOTS AND FASTEN THRU PRE-SLOTTED HOLES 6" WITH PROVIDED NAILS.

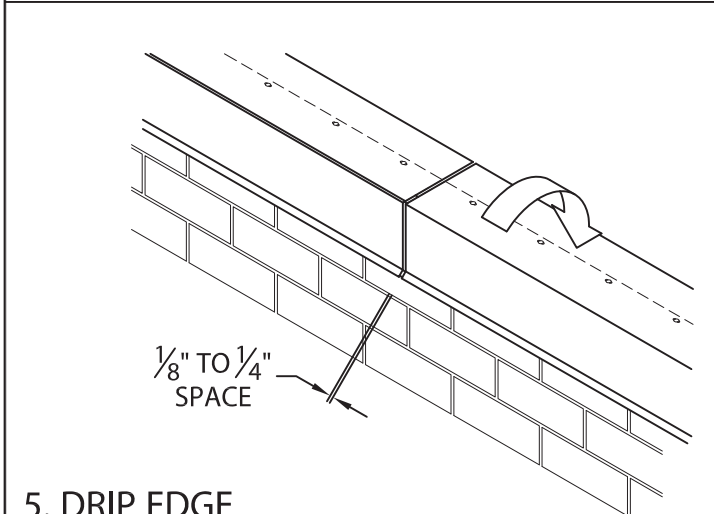

1/8" TO 1/4" SPACE

## 5. DRIP EDGE

CONTINUE INSTALLING LENGTHS OF DRIP EDGE. LEAVE A 1/8" TO 1/4" SPACE BETWEEN PIECES.

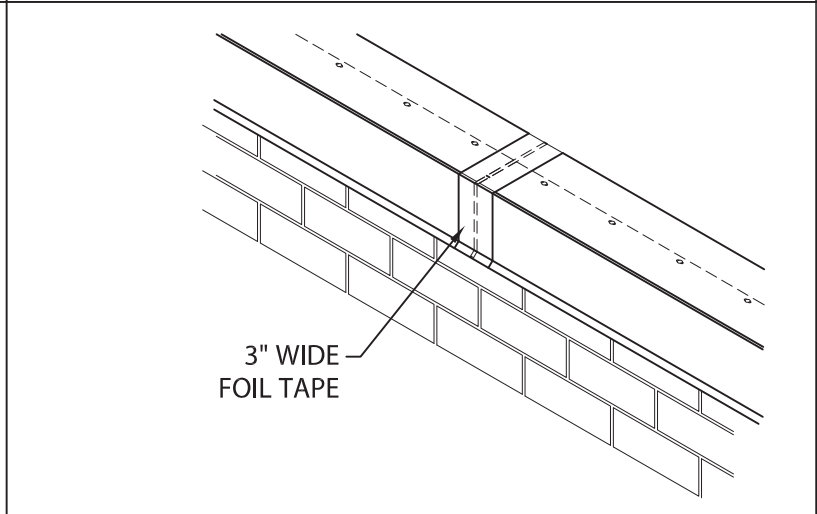

3" WIDE FOIL TAPE

## 6. FOIL TAPE AT JOINT

PLACE A 3" WIDE PIECE OF FOIL TAPE OVER JOINT.



Phone: 800-558-2162  
Fax: 800-373-9156  
www.metalera.com/genflex

DATE: 06/14/21  
DRN BY: JJC  
CKD BY: MM

SHT.# 1 OF 2  
DWG# 22110-36399

A

# GENFLEX TPO SKIRTED DRIP EDGE

TPO VERSION WITH FACTORY APPLIED TPO FLASHING WITH CONTINUOUS CLEAT

NOTE: INSTALL MITERS FIRST

INSTALLATION INSTRUCTIONS

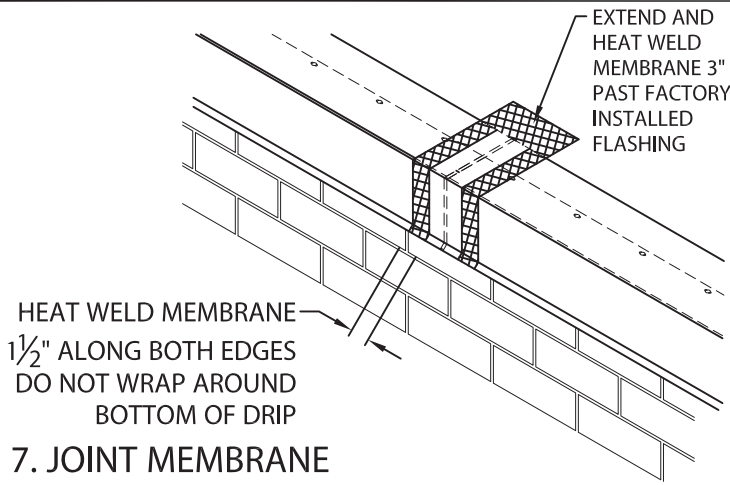

HEAT WELD MEMBRANE  
1½" ALONG BOTH EDGES  
DO NOT WRAP AROUND  
BOTTOM OF DRIP

## 7. JOINT MEMBRANE

HEAT WELD A 6" WIDE PIECE OF NON-REINFORCED MEMBRANE OVER JOINT AS SHOWN ABOVE.

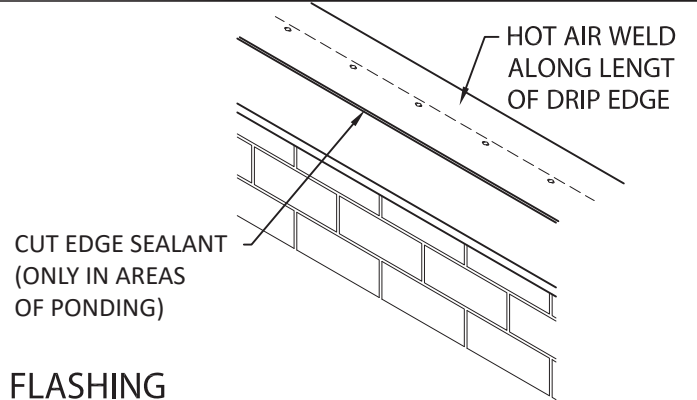

CUT EDGE SEALANT  
(ONLY IN AREAS  
OF PONDING)

## 8. FLASHING

HOT AIR WELD ALONG ENTIRE LENGTH OF DRIP EDGE PER MANUFACTURERS INSTRUCTIONS.

APPLY CUT EDGE SEALANT (ONLY IN AREAS OF PONDING)

## TYPICAL INSTALLATION

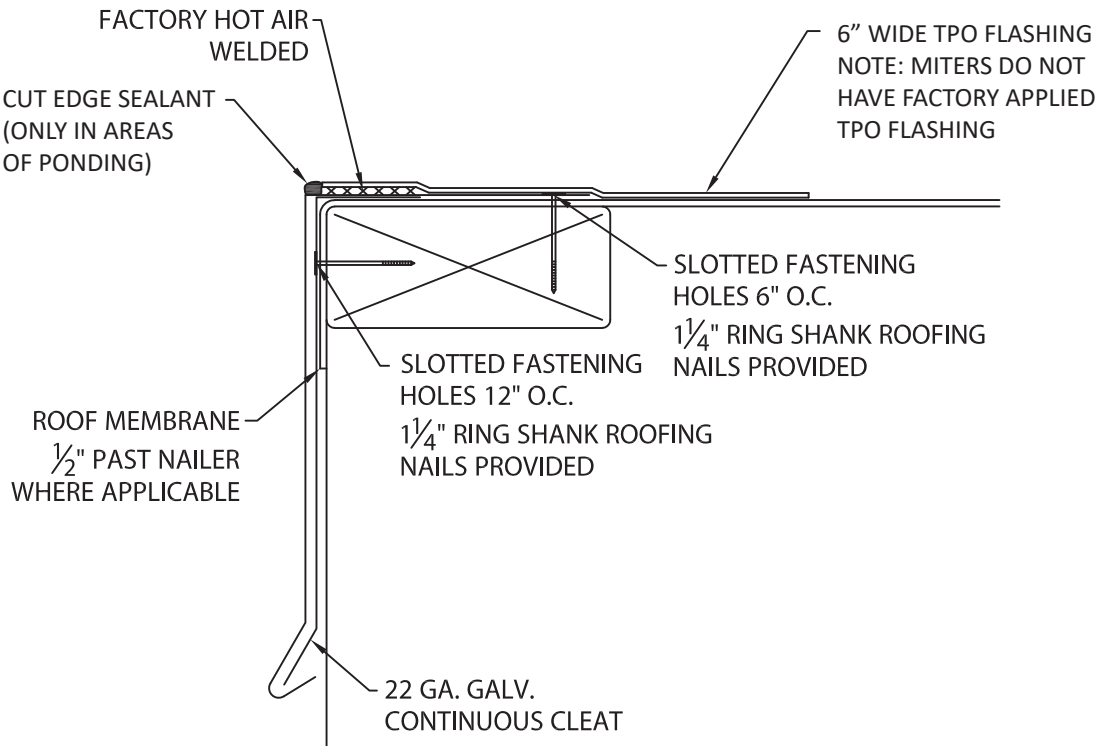

Phone: 800-558-2162  
Fax: 800-373-9156  
www.metalera.com/genflex

DATE: 06/14/21  
DRN BY: JJC  
CKD BY: MM

SHT.# 2 OF 2

DWG# 22110-36399

A