



# Installation Guide for EdgeBox RI

1600 Airport Road  
Waukesha, WI 53188  
Phone: (800) 558-2162  
[WWW.METALERA.COM](http://WWW.METALERA.COM)

DATE: 10/7/22 | DRN BY: PL | CKD BY: PL | DWG #: 11118-38095 | REV: A

# Installation Guide for EdgeBox RI



ANSI/SPRI/FM4435/ES-1 TESTED

**NOTES:**

#1 - Isolate all metal parts from ACQ treated wood or other galvanically incompatible material with appropriate membrane material.  
 #2 - Appliance attachments, such as lightning rods, signs, or antennae that penetrate the edge system, induce a galvanic reaction, or otherwise compromise the effectiveness of the roof edge system, shall be eliminated or isolated to prevent problems per ANSI/SPRI/FM4435/ES-1. Lightning protection systems for example must not be directly affixed to the product provided by the manufacturer. Consult the manufacturer for alternative attachment suggestions.

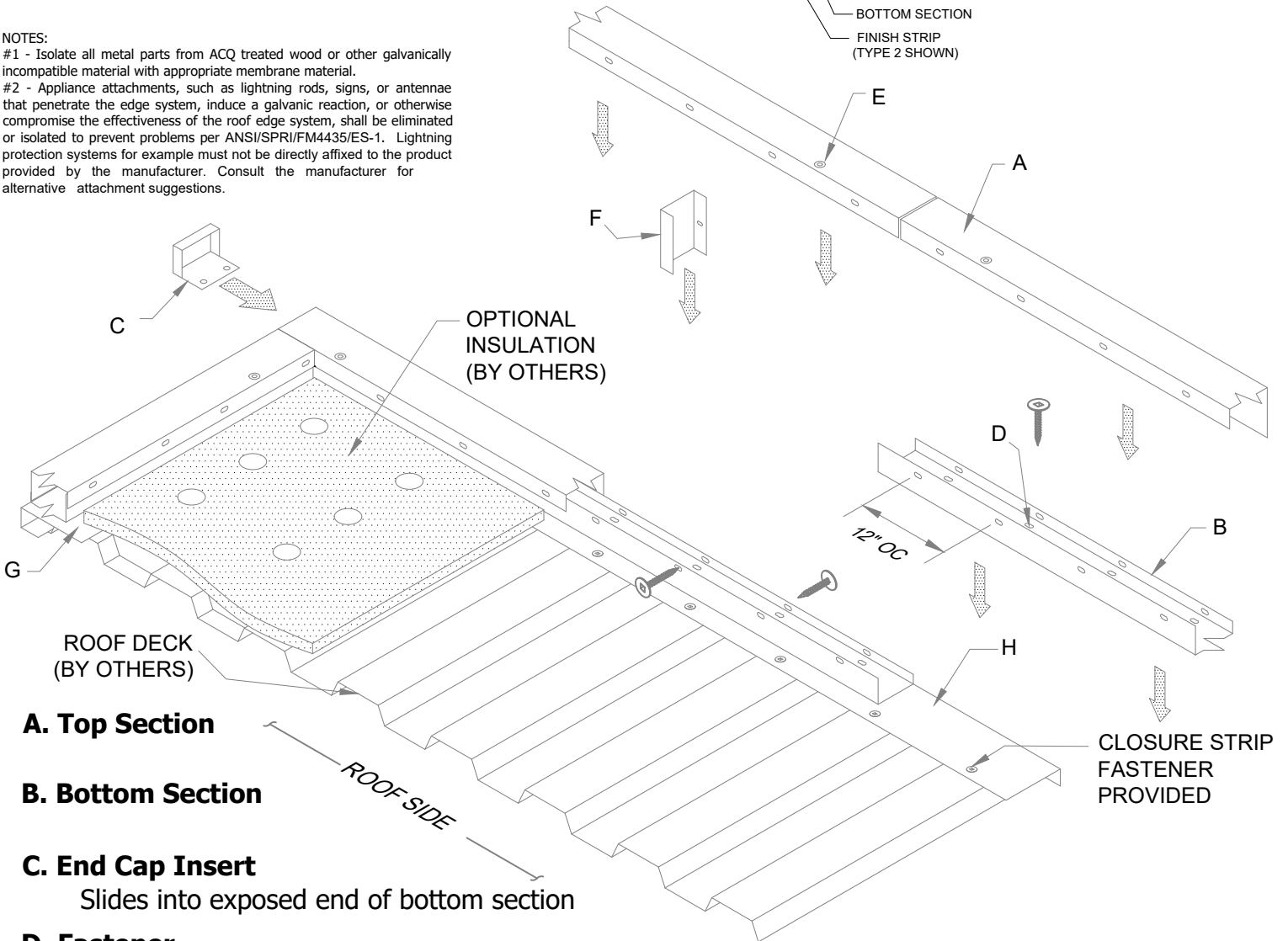
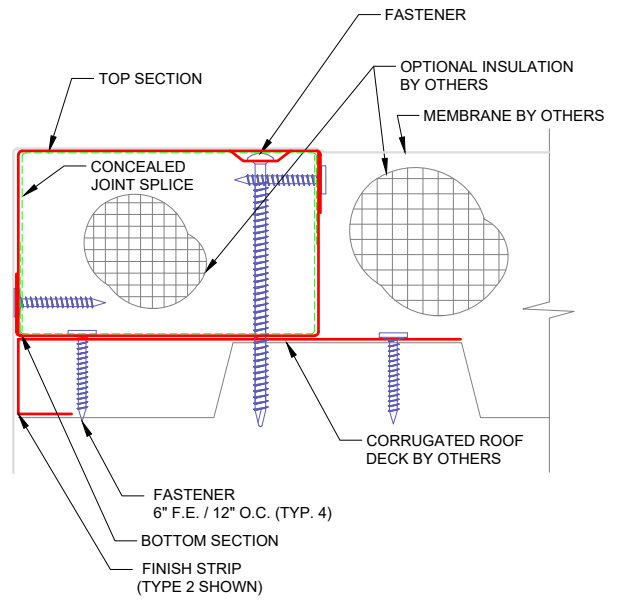

**A. Top Section**

**B. Bottom Section**

**C. End Cap Insert**

Slides into exposed end of bottom section

**D. Fastener**

Included and required

**E. Fastener**

Size varies based on height of EdgeBox  
 min. 1" penetration required

**F. EdgeBox Spine**

Required for height or width greater than 6"

**G. Finish Strip**

Parallel to deck flutes  
 (required for metal deck)

**H. Closure Strip**

Perpendicular to deck flutes  
 (required for metal deck)

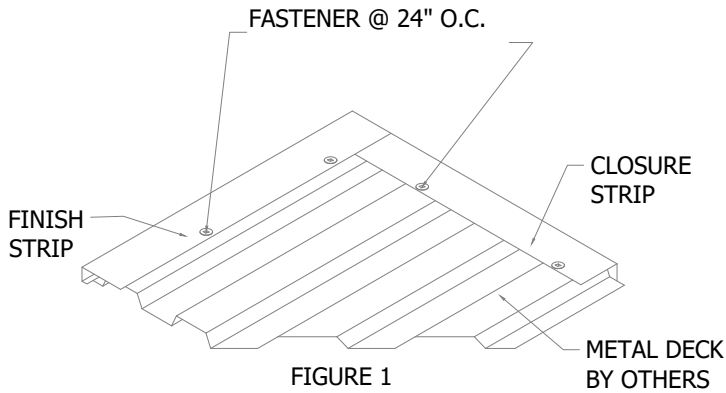

### STEP 1: Installing Closure Strip & Finish Strip

Required for metal deck only. Place appropriate strips on the edge of the metal deck. Secure in place with provided fastener. Fastener heads not to interfere with bottom sections.

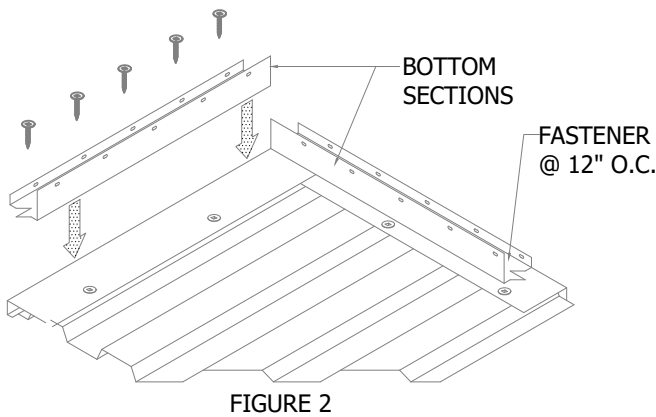

FIGURE 2

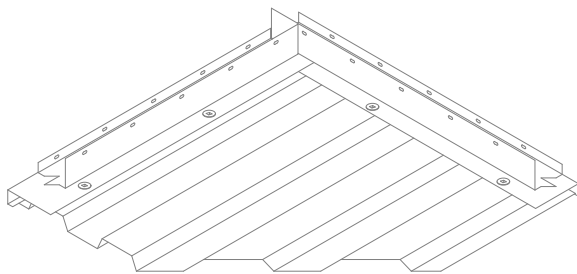

FIGURE 3

### STEP 2: Installing Bottom Section

Starting at the corners, place bottom sections as shown above working from the corners to the center. Secure in place using provided fasteners through pre-punched holes. Butt adjacent sections against original.

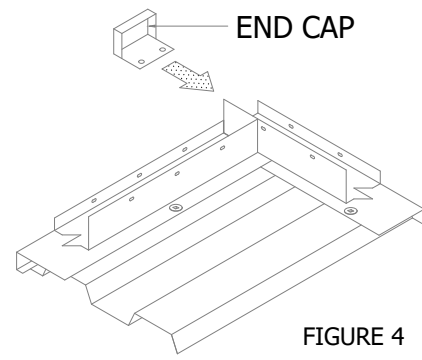

FIGURE 4

### STEP 4: Installing End Caps

Place end cap in exposed end of bottom section, secure with provided fastener (2 per end cap).

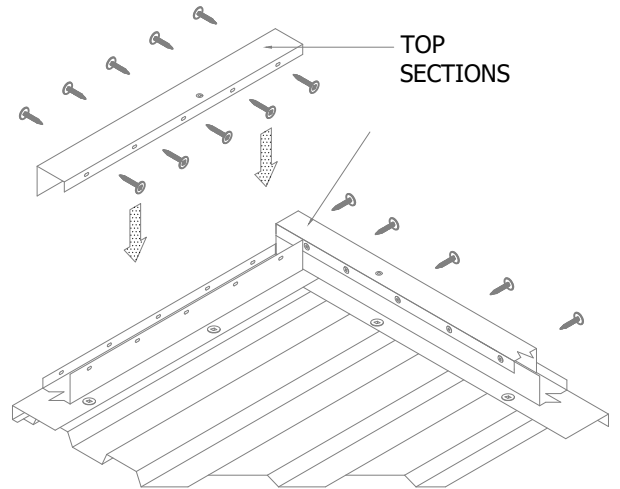

FIGURE 5

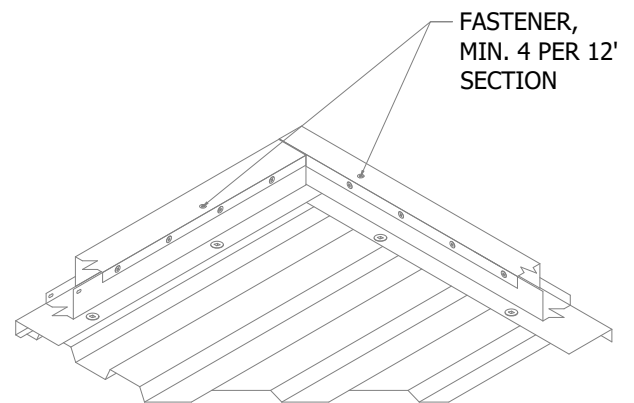

FIGURE 6

### STEP 5: Installing Top Section

Starting at the corners, place top sections as shown in FIGURE 5. Working from the corners to the center, consider lengths of middle pieces prior to cutting to avoid creating relatively short sections (less than 5'-0"). Secure top to bottom using fastener through pre-punched holes in the face and through pre-punched holes in the back. Secure top to substrate using fastener through counter-sunk pre-punched holes, through edgebox assembly into substrate. Butt adjacent sections against original.