

PLEASE READ

TECH BULLETIN: “PINKING” OF TPO PRODUCTS

You may notice a pink, red or orangish coloration called "pinking" on the surface of TPO products and samples. Please note that this is a **temporary** coloration. The “pinking” **will** go away within 24 hours of being installed once it is exposed to UV light. It’s important that the product is **installed** and **exposed completely** for the UV light to reach the full product.

Many TPO products contain a stabilization/weathering package which includes very powerful antioxidants that help protect the finished product from degradation due to heat induced thermal oxidation and sunlight induced photo-oxidation. Certain antioxidants in some weathering packages are particularly effective, but they are susceptible to pinking under the right environmental conditions, usually during storage. Pinking or "gas fading" is a surface reaction of these antioxidants with air pollutants, mostly nitrous oxides and sulfur oxides, produced in combustion processes. Pinking occurs over time on unweathered TPO surfaces that are exposed to polluted air, particularly in the absence of light.

As mentioned this is a temporary condition. The pinking will disappear upon exposure to sunlight and weathering in general once the product is completely installed. The products are not stained or permanently discolored in any way.



ELEVATE COATED DRIP EDGE

PVC AND TPO VERSION WITH CONTINUOUS CLEAT

NOTE: INSTALL MITERS FIRST

INSTALLATION INSTRUCTIONS

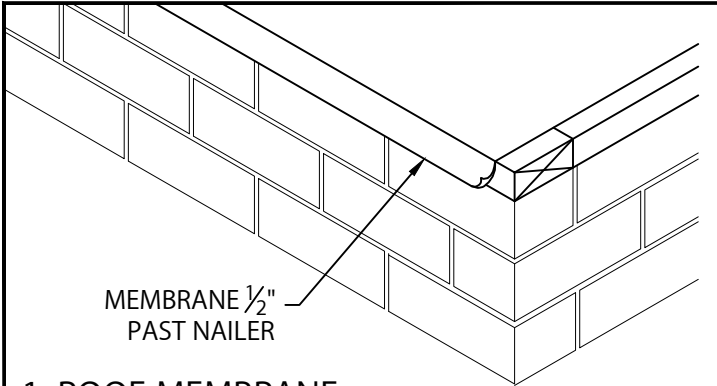

MEMBRANE 1/2" PAST NAILER

1. ROOF MEMBRANE

POSITION MEMBRANE OVER THE ROOF EDGE AND DOWN OUTSIDE FACE OF WALL, COVERING WOOD NAILER(S) COMPLETELY. ALLOW 1/2" EXCESS MEMBRANE.

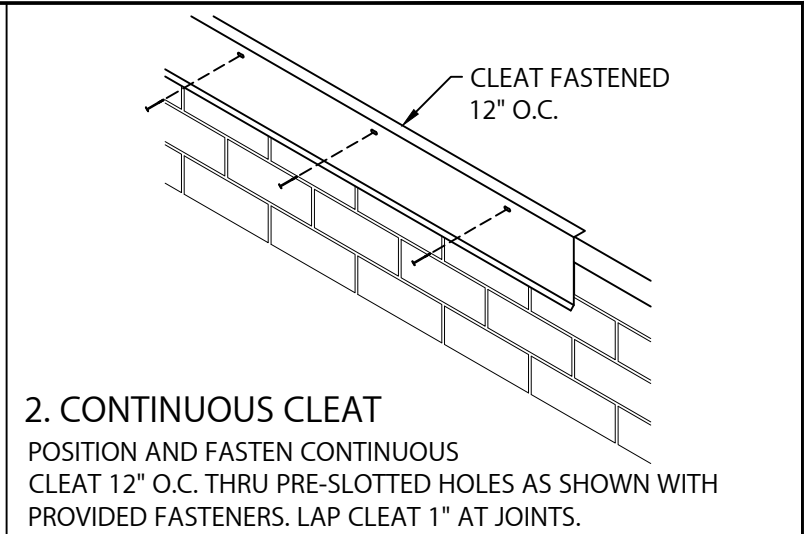

CLEAT FASTENED 12" O.C.

2. CONTINUOUS CLEAT

POSITION AND FASTEN CONTINUOUS CLEAT 12" O.C. THRU PRE-SLOTTED HOLES AS SHOWN WITH PROVIDED FASTENERS. LAP CLEAT 1" AT JOINTS.

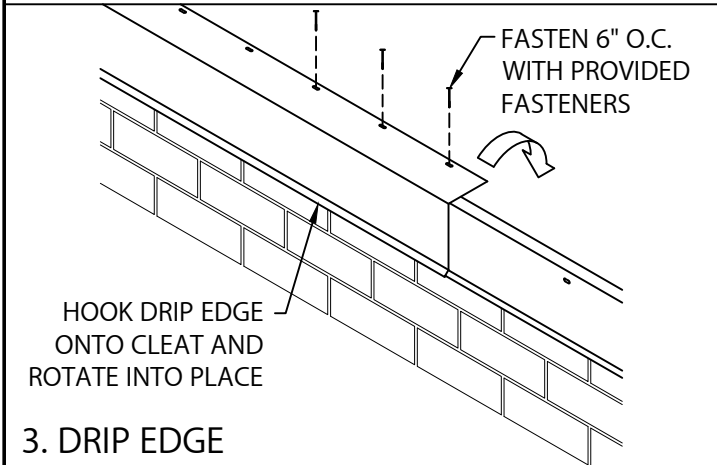

FASTEN 6" O.C. WITH PROVIDED FASTENERS

HOOK DRIP EDGE ONTO CLEAT AND ROTATE INTO PLACE

3. DRIP EDGE

HOOK DRIP EDGE OF EACH DRIP EDGE SECTION ONTO CONTINUOUS CLEAT, ROTATE INTO PLACE. FASTEN THRU PRE-SLOTTED HOLES 6" WITH PROVIDED FASTENERS.

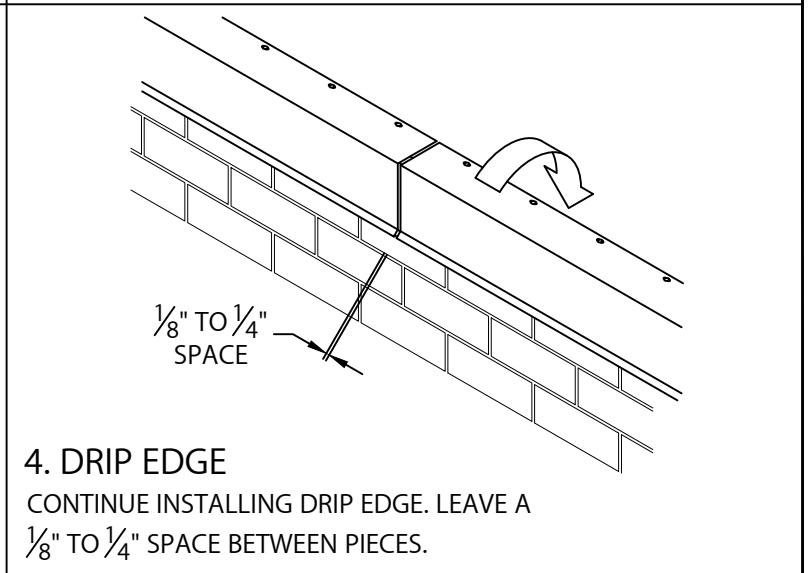

1/8" TO 1/4" SPACE

4. DRIP EDGE

CONTINUE INSTALLING DRIP EDGE. LEAVE A 1/8" TO 1/4" SPACE BETWEEN PIECES.

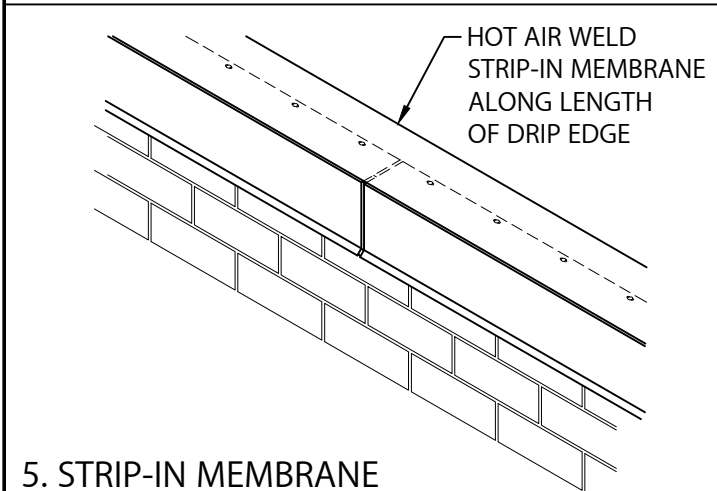

HOT AIR WELD STRIP-IN MEMBRANE ALONG LENGTH OF DRIP EDGE

5. STRIP-IN MEMBRANE

HOT AIR WELD STRIP-IN MEMBRANE ALONG ENTIRE LENGTH OF DRIP EDGE PER MANUFACTURERS INSTRUCTIONS.

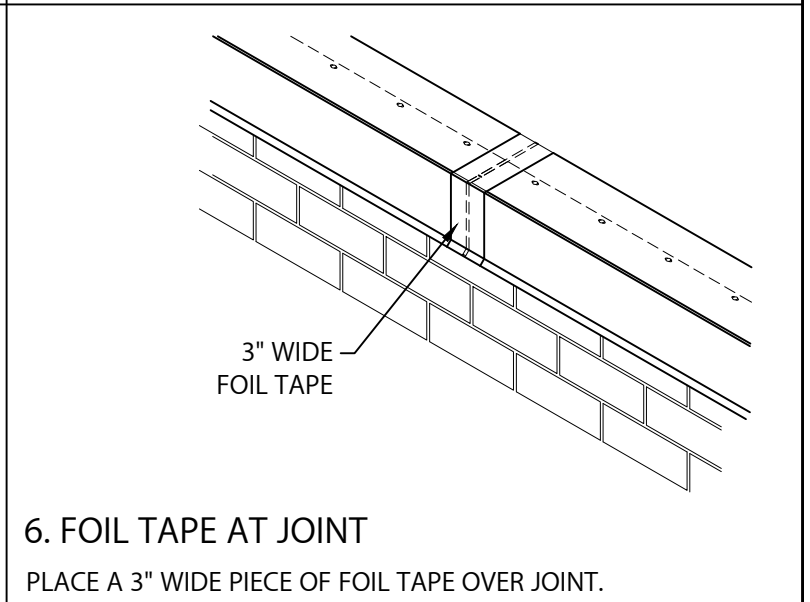

3" WIDE FOIL TAPE

6. FOIL TAPE AT JOINT

PLACE A 3" WIDE PIECE OF FOIL TAPE OVER JOINT.



ELEVATE
26 CENTURY BLVD.
SUITE 205
NASHVILLE, TN 37214

CONTACT YOUR LOCAL ELEVATE REPRESENTATIVE

DATE: 03/23/23

DRN BY: MLM

CKD BY: MM

SHT.# 1 OF 2

DWG# 13110-21963

E



ELEVATE COATED DRIP EDGE

PVC AND TPO VERSION WITH CONTINUOUS CLEAT

NOTE: INSTALL MITERS FIRST

INSTALLATION INSTRUCTIONS

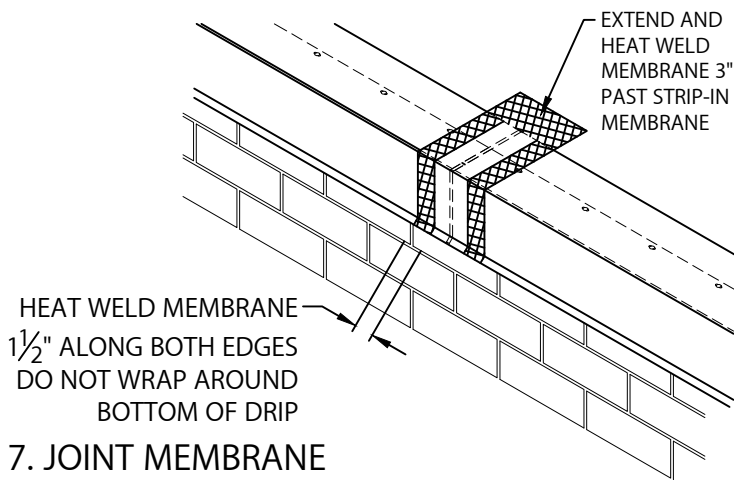

HEAT WELD A 6" WIDE PIECE OF NON-REINFORCED MEMBRANE OVER JOINT AS SHOWN ABOVE.

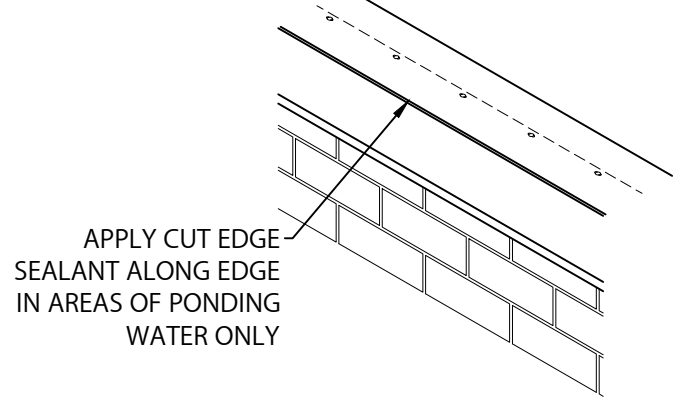

8. SEALANT

APPLY CUT EDGE SEALANT ONLY TO EDGES WHERE PONDING OCCURS.

TYPICAL INSTALLATION

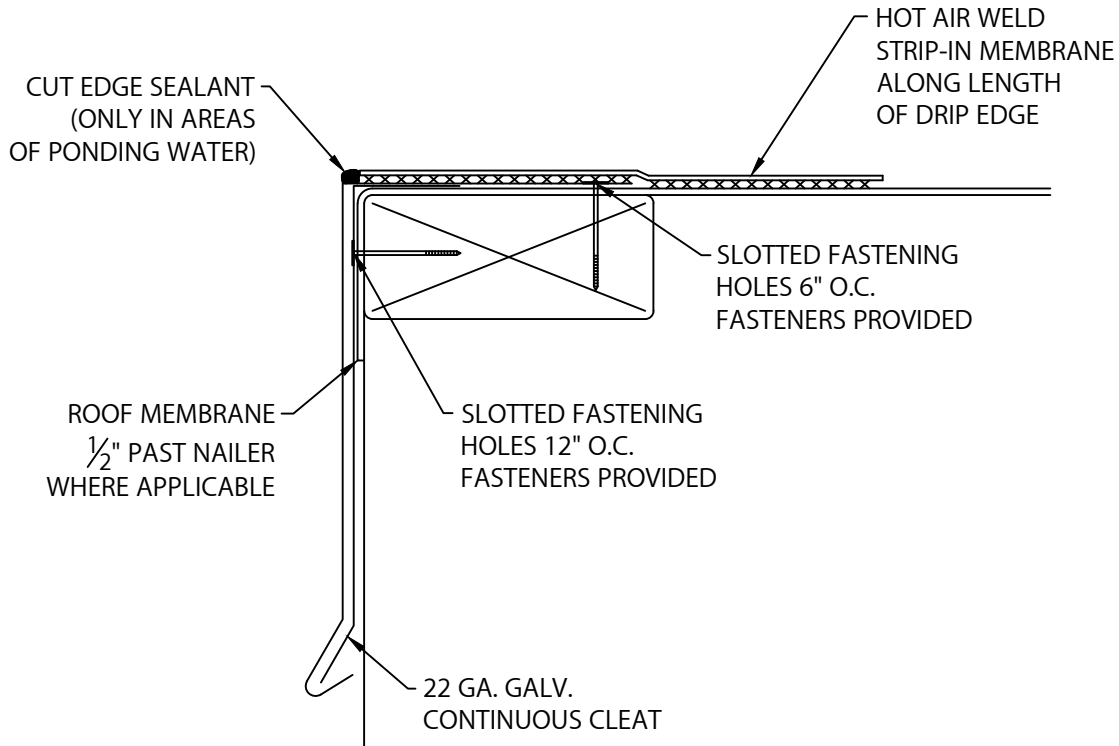

ELEVATE
26 CENTURY BLVD.
SUITE 205
NASHVILLE, TN 37214
CONTACT YOUR LOCAL ELEVATE REPRESENTATIVE

DATE: 03/23/23
DRN BY: MLM
CKD BY: MM

SHT.# 2 OF 2
DWG# 13110-21963

E