

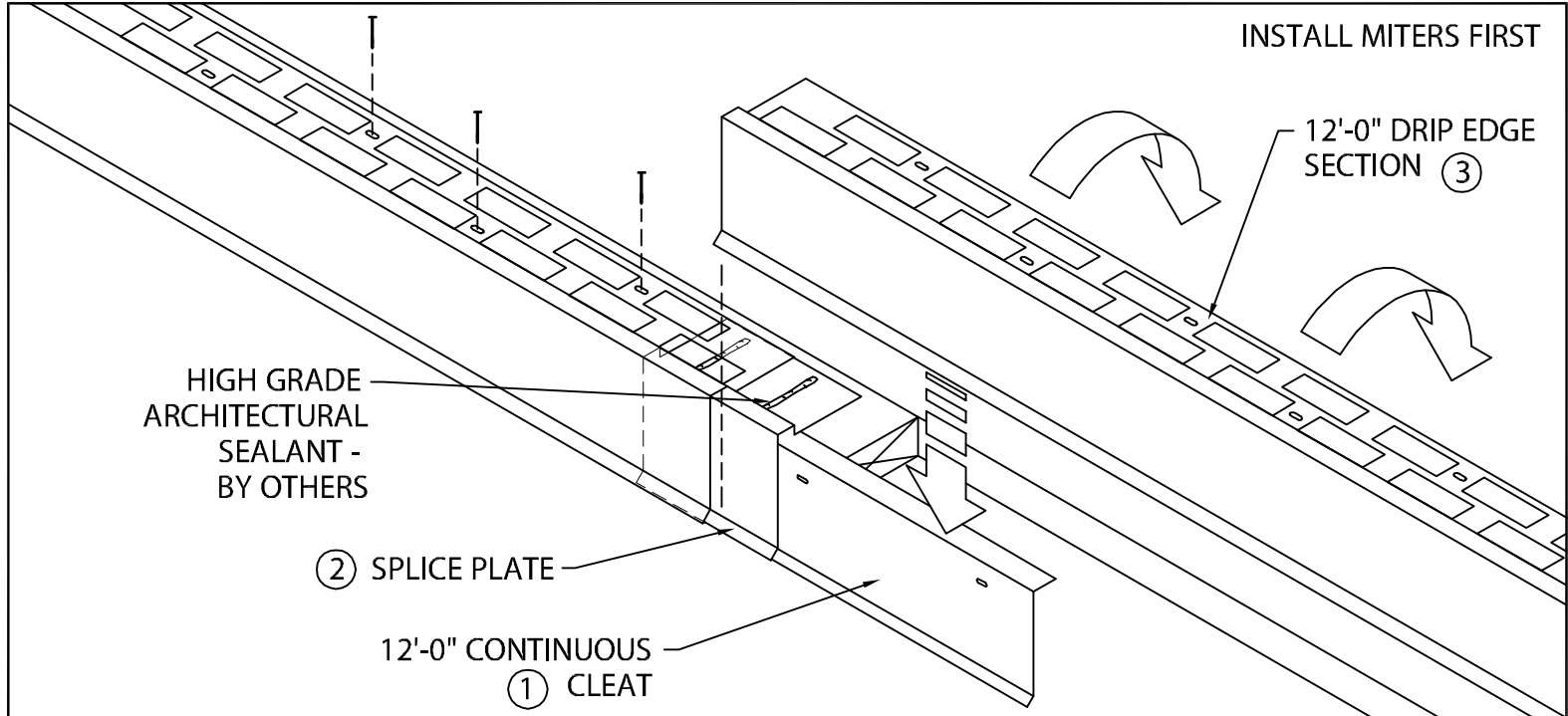

# JOHNS MANVILLE FLASH-THROUGH DRIP EDGE

BUILT-UP OR MODIFIED VERSION WITH CONTINUOUS CLEAT

## INSTALLATION INSTRUCTIONS



INSTALL MITERS FIRST

12'-0" DRIP EDGE SECTION (3)

(2) SPLICE PLATE

12'-0" CONTINUOUS (1) CLEAT

STEP (1) POSITION AND FASTEN CONTINUOUS CLEAT 12" O.C. AS SHOWN WITH PROVIDED 1 1/4" RING SHANK NAILS.

STEP (2) LOCATE AND FASTEN 6" WIDE SPLICE PLATES AT EACH JOINT. SEALANT (BY OTHERS) TO BE FIELD APPLIED TO TOP OF EACH SPLICE PLATE AS SHOWN.

STEP (3) HOOK DRIP EDGE OF EACH DRIP EDGE SECTION ONTO CONTINUOUS CLEAT, ROTATE INTO PLACE, AND FASTEN WITH PROVIDED 1 1/4" RING SHANK NAILS.

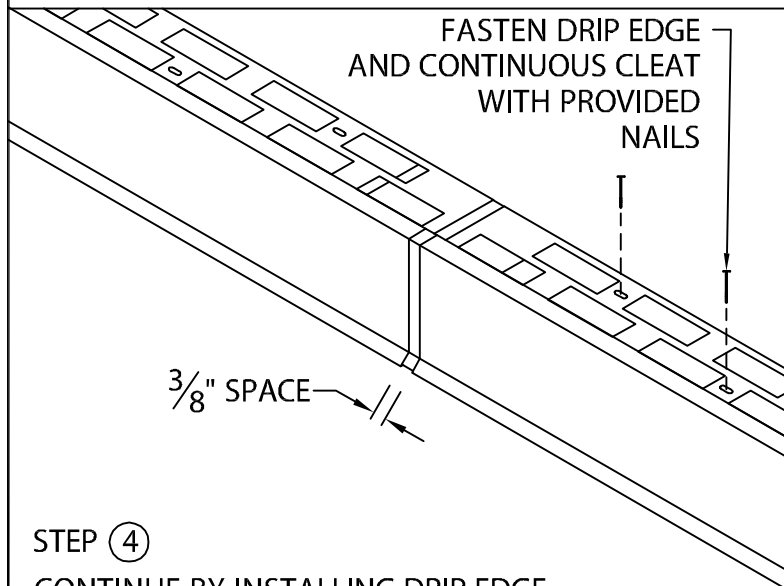

STEP (4) CONTINUE BY INSTALLING DRIP EDGE SECTIONS ALLOWING A 3/8" SPACE BETWEEN SECTIONS AS SHOWN. FIELD CUT AS NECESSARY. REMOVE PROTECTIVE FILM IMMEDIATELY AFTER INSTALLATION. INSTALLERS SHALL WEAR PROTECTIVE EYEWEAR TO PREVENT INJURY.

### TYPICAL INSTALLATION

