



PAVER TERMINATION BAR

WESTILE BALLAST PAVER

NOTES

- Fasteners by others. Use appropriate fasteners as recommended by membrane manufacturer to maintain constant compression seal
- Includes Cover Plates
- For non-90 miters, see separate print approval
- Product should be installed per provided installation instructions

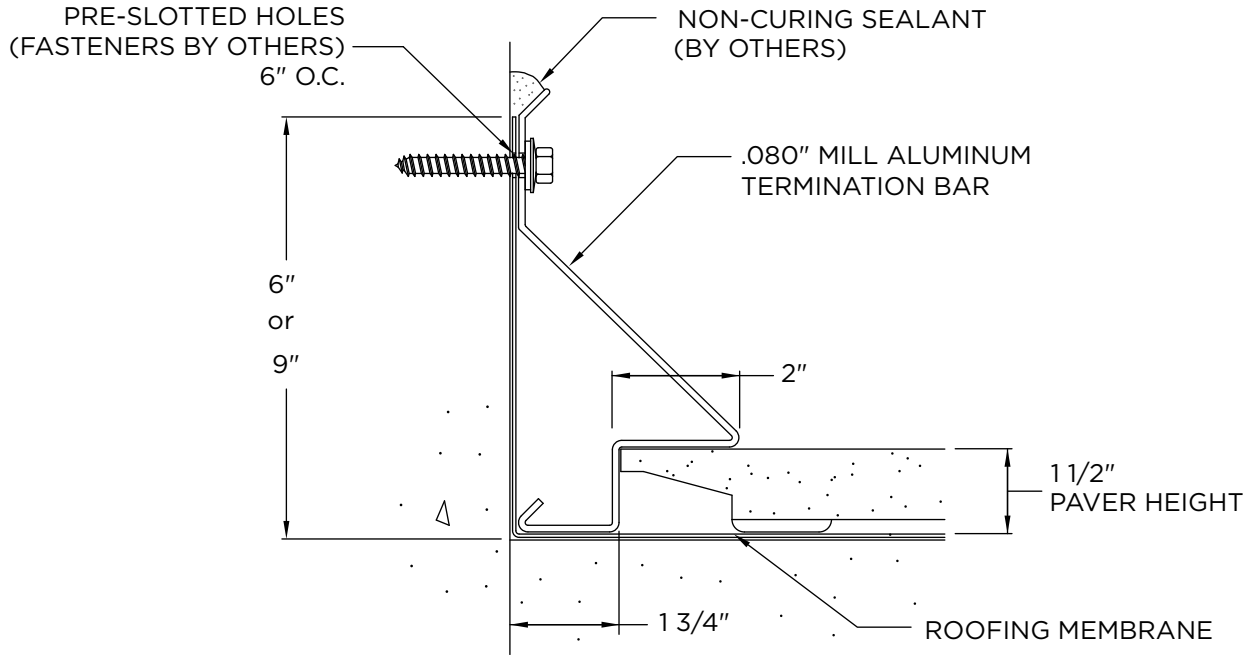

PROJECT INFO

Project Name: _____

Architect: _____

Roofing Contractor: _____

Project Type:

By selecting this box you have verified and confirmed that dimensions, sizes, and quantities are correct. All products will be installed in strict accordance with printed instructions.

Date: _____

SHT# 1 of 1

DATE: " & ") ! \$ %

DRN BY: JJC

CKD BY: MM

8 K ; , . SSSSSSSSS

REV: D

Elevate
 26 Century Blvd.
 Suite 205
 Nashville, TN 37214
 Contact your local
 Elevate representative.

DIMENSIONS

- 6" (WL-660)
- 9" (WL-690)

MATERIAL

.080" Mill Finish Aluminum

QUANTITIES

_____ Lineal Feet (12'-0" Lengths)

_____ Welded Outside Miters (90°)

_____ Welded Inside Miters (90°)