

FLEXCAP FLC WELDED RADIUS COPING

TAPERED VERSION

IMPORTANT!!! MUST INDICATE PROPER RADIUS CONDITION BY CIRCLING APPROPRIATE OUTSIDE FACE

PROVIDING A RADIUS
THE RADIUS MAY BE PROVIDED
IN ONE OF TWO METHODS:

1.) THE ACTUAL KNOWN RADIUS IS

' FEET " INCHES MINIMUM OF 3'-0"

OR

2.) FIELD CONDITION MEASUREMENTS

NOTE: REFER TO ATTACHED WORKSHEET
FOR FURTHER INFORMATION

" INCHES

RISE MAXIMUM
OF 4 ³/₄"

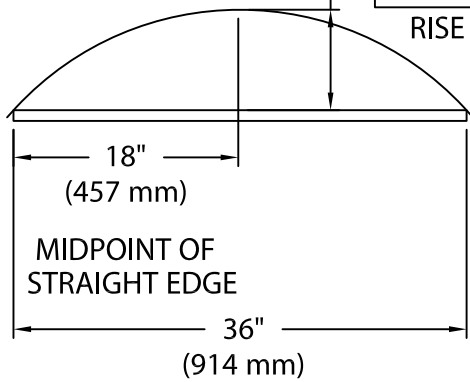

LENGTH OF
STRAIGHT EDGE

NOTE: CHECK MEASUREMENTS ALONG ENTIRE RADIUS.

DETAIL A

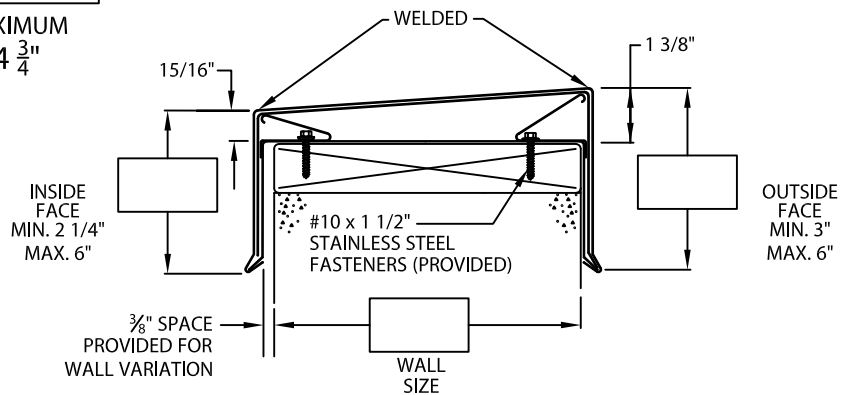
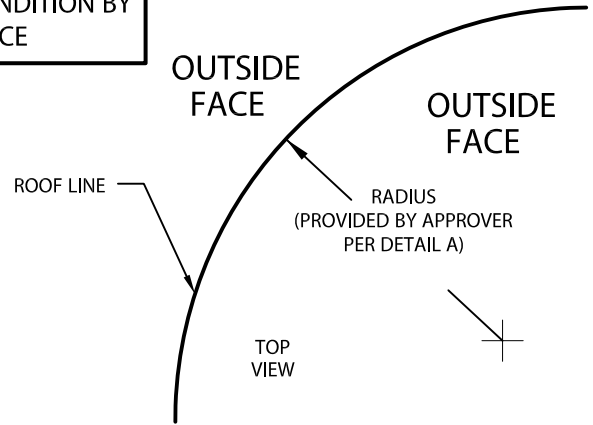

NOTES: -- Concealed splice plates are provided with factory applied dual non-curing sealant strips.

MATERIALS:

Top - .080" Alum.

Sides - .063" Alum.

Color: _____

Finish: _____

QUANTITIES:

_____ Lineal Feet 4'-0" Lengths

Fabrication will proceed only after receipt of signed print approval.

Print Approval:

Architect and/or contractor shall verify all dimensions, sizes and quantities. All products to be installed in strict accordance with Flex's printed instructions.

Approved by: _____

Date: _____

PROJECT:

ARCHITECT:

ROOFING CONTRACTOR:

REPRESENTATIVE/DISTRIBUTOR:

Customer Service:

Phone: 800-969-0108

Fax: 610-916-9501

Flex™

DATE: 12/19/16

DRN BY: JAB

CKD BY: SAK

SHT.# ___ OF ___

DWG# 28011-3478

D