

INDUSTRIAL EXTERNAL GUTTER BRACKET

IG-2 VERSION

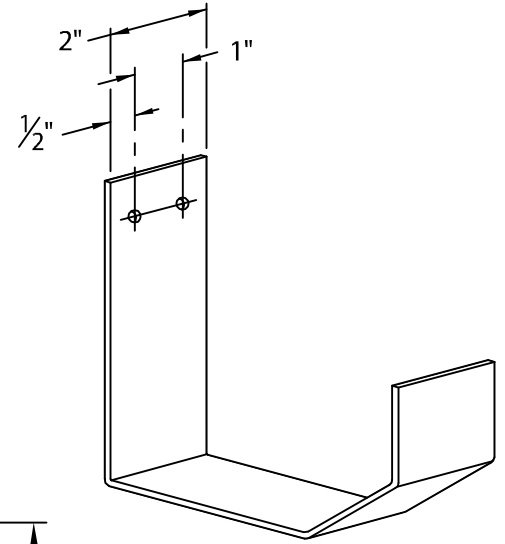
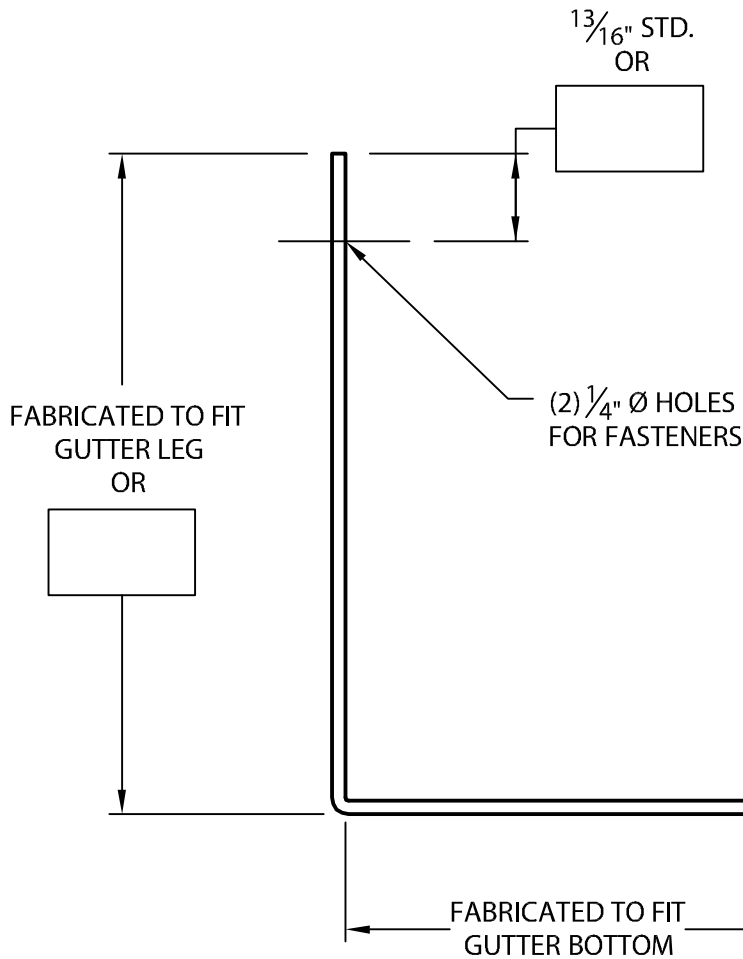

ISOMETRIC VIEW

2" WIDE BRACKET

Fabrication will proceed only after receipt of signed print approval.

Print Approval:

Architect and/or contractor shall verify all dimensions, sizes and quantities. All products to be installed in strict accordance with FiberTite's printed instructions.

Approved by: _____

Date: _____

MATERIAL:

.125" ALUMINUM

COLOR: _____

FINISH: _____

QUANTITIES:

_____ AMOUNT REQUIRED*

*QUANTITIES OVER 200 REQUIRE AN EXTENDED LEAD TIME DUE TO POST COATING PROCESS.

PROJECT:

ARCHITECT:

ROOFING CONTRACTOR:

REPRESENTATIVE/DISTRIBUTOR:

Customer Service

1-800-355-6416



DATE: 03/04/16

DRN BY: JJC

CKD BY: SAK

SHT.# ____ OF ____

DWG# 23012-4217

C