

PRESTO-LOCK RADIUS COPING

EXISTING SLOPE WITHOUT NAILER VERSION - 4'-0" O.C.

INSTALLATION INSTRUCTIONS

NOTE: Position Johns Manville roofing membrane up and over the top of the wall and down the outside face of the wall covering the treated wood nailer(s) completely. Allow 1/2" excess membrane if necessary.

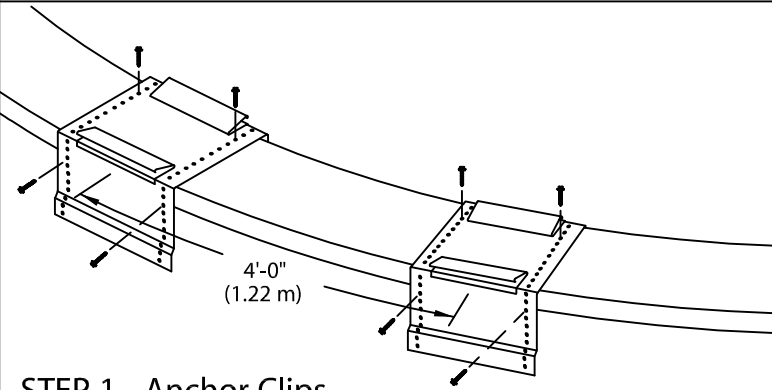

STEP 1 - Anchor Clips

Locate and fasten 8" (203 mm) wide anchor clips at 4'-0" (1.22 m) O.C. with provided fasteners for substrate (see detail A).

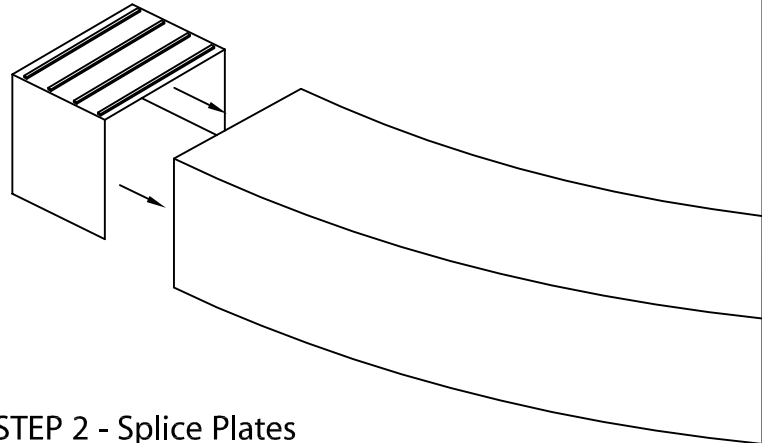

STEP 2 - Splice Plates

Remove release paper from left two sealant strips. Insert splice plate into the right end of radius section.

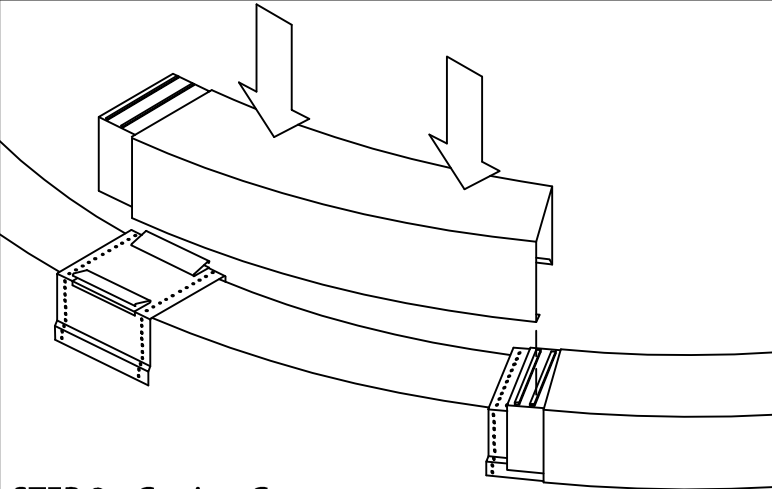

STEP 3 - Coping Cover

Remove release paper from right two factory applied sealant strips on the splice plate in the coping section. Install 4'-0" (1.22 m) radius coping sections from left to right. Place coping into position and press downward until snap-lock occurs.

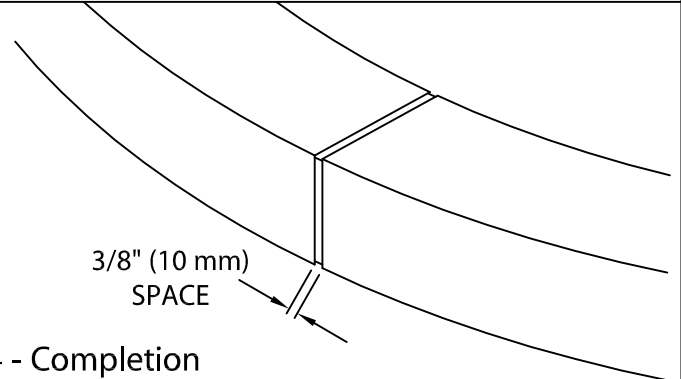

STEP 4 - Completion

Continue installing coping with a 3/8" (10 mm) space at splice joints to allow for thermal expansion. Field cut where necessary using a fine tooth hacksaw or snips.

NOTE: REMOVE PROTECTIVE FILM IMMEDIATELY.

LOCATE PROVIDED FASTENER IN THIRD FULL HOLE FROM BEND

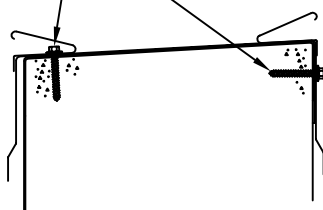

ANCHOR CLIP FASTENING-DETAIL A

TYPICAL COPING INSTALLATION

