

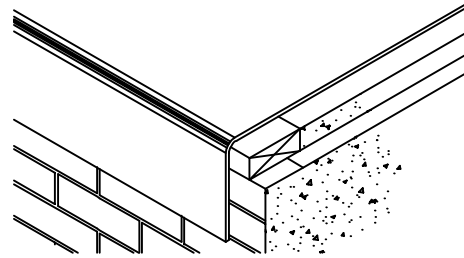

# DERBIGUM ONE EDGE

LAP JOINT VERSION

## INSTALLATION INSTRUCTIONS

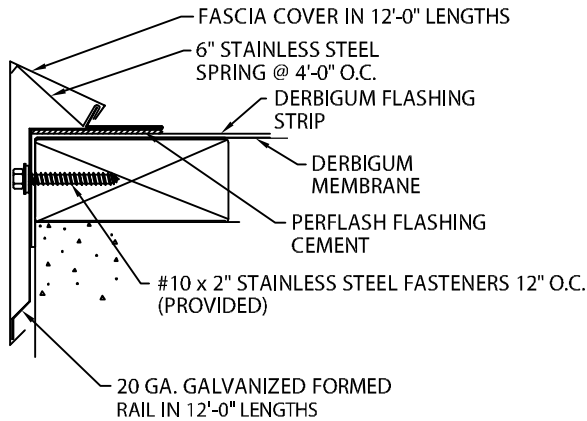

### STEP 1 - MEMBRANE

POSITION BASE SHEET OF THE MODIFIED ROOFING MEMBRANE OVER THE ROOF EDGE COVERING NAILS COMPLETELY.

NOTE: FOLLOW GENERAL RECOMMENDATIONS OF THE DERBIGUMS APPLICATION OF THE MEMBRANE OVER THE EDGE.

CAUTION: TAKE EXTREME CARE TO AVOID SPILLAGE OF THE ASPHALT OVER THE EDGE

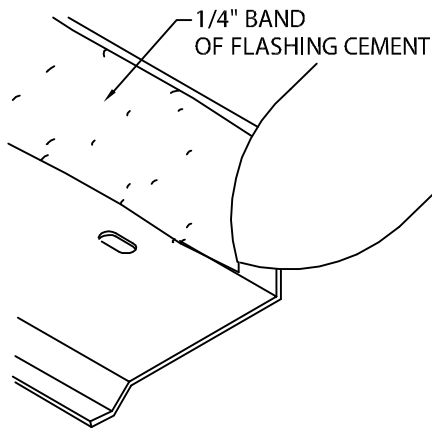

BASE RAIL SHOWN WITH INSIDE FACE UP.

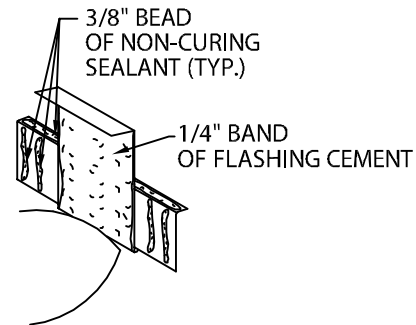

### STEP 2 - BASE RAIL (PREPARATION)

LAY THE BASE RAIL ON THE DECK WITH THE OUTSIDE FACE DOWN. IF NECESSARY, CLEAN THE BACK SIDE OF THE BASE RAIL OF DUST OR DIRT. APPLY A HEAVY 1/4" BAND OF FLASHING CEMENT TO THE BACK OF THE DECK FLANGE FOR THE ENTIRE LENGTH OF THE RAIL AS SHOWN

### STEP 3 - BASE RAIL SPLICE PLATE

APPLY A HEAVY 1/4" BAND OF FLASHING CEMENT TO THE BOTTOM OF THE 2" WIDE DECK FLANGE OF THE RAIL SPLICE PLATE AS SHOWN.

NEXT, APPLY 3/8" BEADS OF NON-CURING SEALANT TO TOP AND SIDES OF THE RAIL SPLICE AS SHOWN.



Customer Service  
1-800-727-9872

DATE: 02/08/17  
DRN BY: JJC  
CKD BY: SAK

SHT.# 1 OF 5  
DWG# 20110-25641

A



# DERBIGUM ONE EDGE

LAP JOINT VERSION

## INSTALLATION INSTRUCTIONS

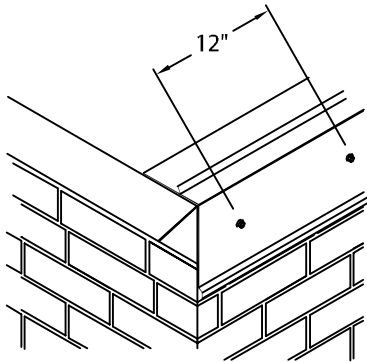

### STEP 4 - OUTSIDE MITERS

ON THE BUILDING CORNER, IDENTIFY THE "DOG EAR" OR THE OVERLAP OF THE FLASHING STRIP. FASTEN A 12'-0" SECTION OF BASE RAIL, PREPARED WITH FLASHING CEMENT AS SHOWN IN STEP #2, TO THE OPPOSITE FACE, WITH THE END EVEN WITH THE EDGE OF THE WALL. FASTEN IN PLACE THROUGH THE RAIL SLOTS 12" O.C. WITH PROVIDED FASTENERS.

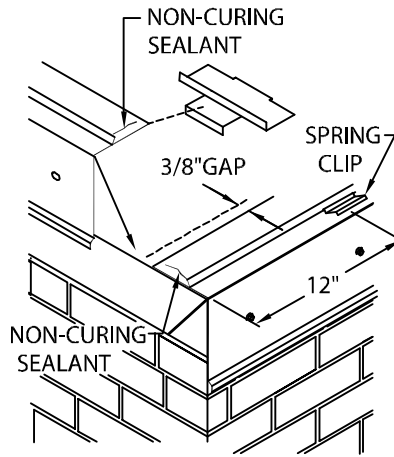

### STEP 5 - OUTSIDE MITERS

APPLY NON-CURING SEALANT ADJOINING ENDS OF BASE RAIL AS SHOWN. SLIDE BASE RAIL SPLICE PLATE OVER THE EDGE OF 12'-0" RAIL SECTION. INSTALL RAIL SECTION TO "DOG EAR" SIDE OF THE WALL, LEAVING A 3/8" GAP TO ADJOINING RAIL. FASTEN TO NAILER THROUGH SLOTS 12" O.C. & 24" O.C. WITH PROVIDED FASTENERS. FIELD CUT AS NEEDED. LOCATE 6" SPRING CLIPS AT MITER COVER SPLICE PLATE OR NO FURTHER THAN 12" FROM CORNER. THEN 4'-0" O.C., MAKING SURE THERE WILL BE A SPRING CLIP UNDER EACH FASCIA COVER END.

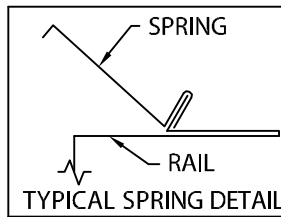

Customer Service  
1-800-727-9872

DATE: 02/08/17  
DRN BY: JJC  
CKD BY: SAK

SHT.# 2 OF 5

DWG# 20110-25641

**A**



# DERBIGUM ONE EDGE

LAP JOINT VERSION

## INSTALLATION INSTRUCTIONS

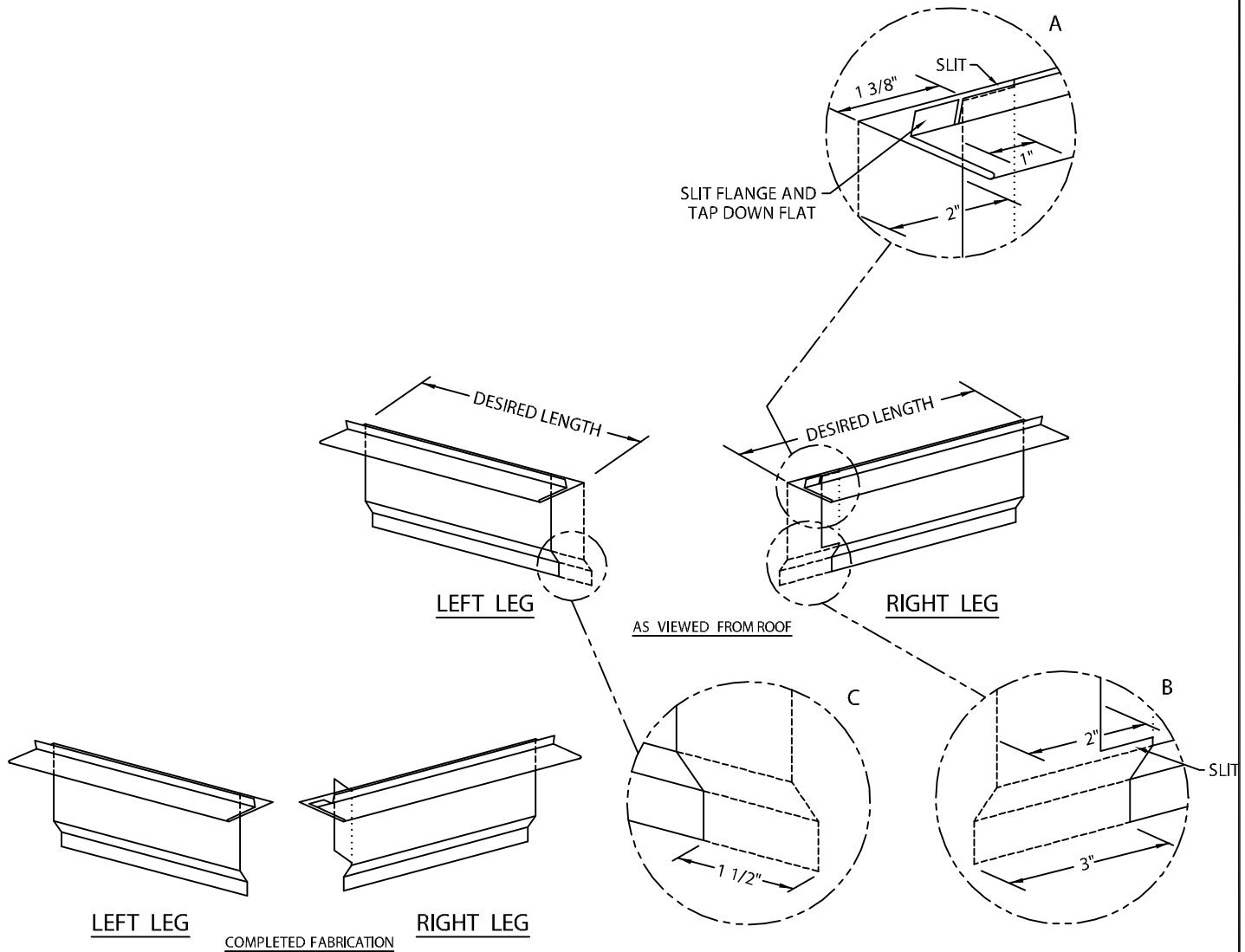

### STEP 6 - INSIDE MITER RAIL FABRICATION (CUT RAIL TO DESIRED LENGTH)

FOR RIGHT LEG-SEE DETAIL A: ON THE TOP FLANGE CUT SLIT  $1\frac{3}{8}$ " FROM THE END AND TAP DOWN FLAT. TRIM BACK THE FRONT FACE  $2"$  AND SLIT FACE  $1"$  AS SHOWN. DETAIL B: ON THE BOTTOM FLANGE TRIM BACK  $3"$ . SLIT FACE  $1"$  CREATING A  $1"$  TAB. BEND THE TAB OUTWARDS  $90^\circ$ . FOR LEFT LEG- DETAIL C: TRIM ENTIRE FACE AND BOTTOM FLANGE BACK  $1\frac{1}{2}"$  AS SHOWN.



Customer Service  
1-800-727-9872

DATE: 02/08/17  
DRN BY: JJC  
CKD BY: SAK

SHT.# 3 OF 5

DWG# 20110-25641

A



# DERBIGUM ONE EDGE

LAP JOINT VERSION

## INSTALLATION INSTRUCTIONS

### STEP 7 - OUTSIDE MITER COVER FABRICATION (CUT COVER TO DESIRED LENGTH)

RIGHT LEG - DETAIL A: CREATE TAB BY REMOVING 1" PORTION OF TOP FLANGE AND EXTEND REMOVAL 1/8" DOWN FACE.

DETAIL B: CUT TOP FLANGE AT ANGLE 2" AS SHOWN. DETAIL C: CUT LOWER FLANGE AT AN ANGLE 3/4" AS SHOWN.

BEND 1" TAB 90° INWARD AS SHOWN.

LEFT LEG - DETAIL D: CUT TOP FLANGE AT ANGLE 2" AS SHOWN. DETAIL E: CUT LOWER FLANGE AT AN ANGLE 3/4" AS SHOWN.

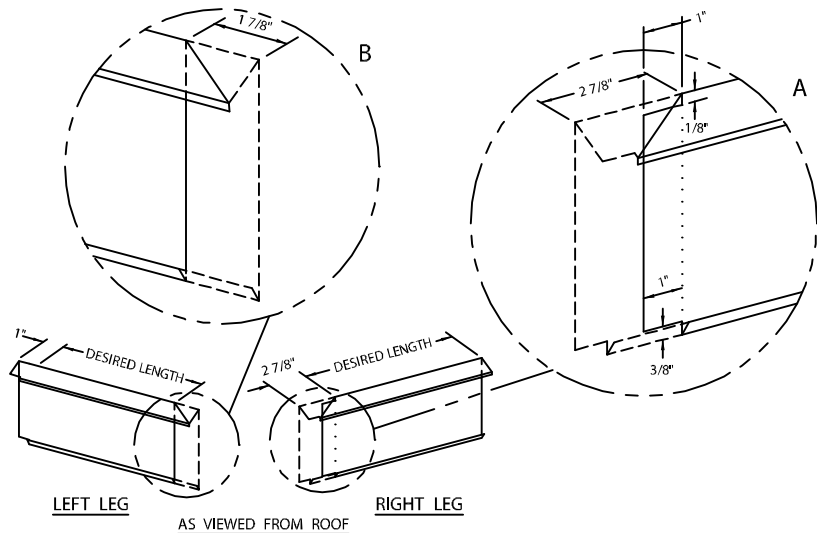
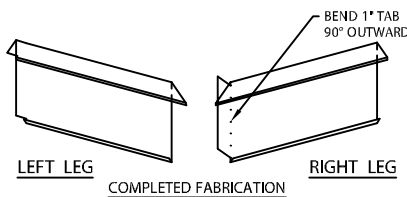
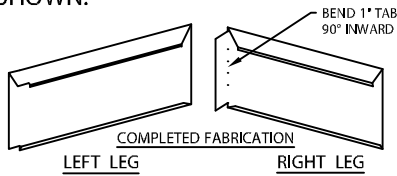
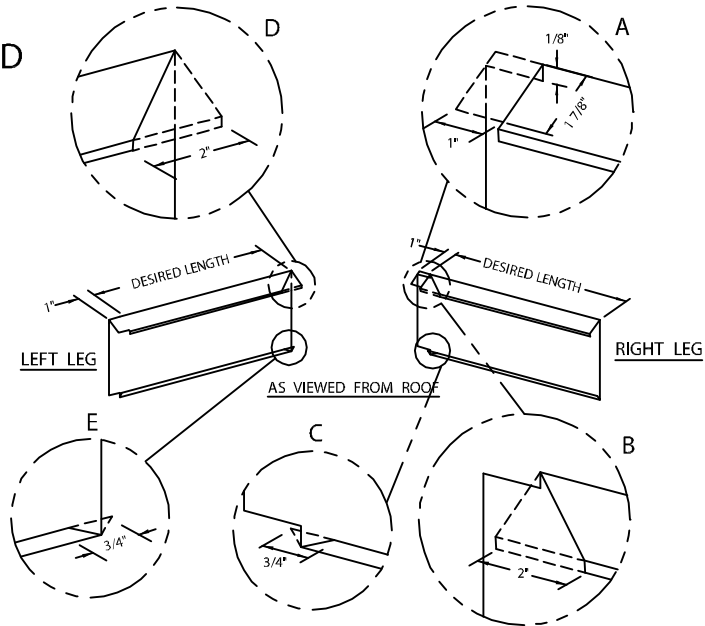

### STEP 8 - INSIDE MITER COVER FABRICATION (CUT COVER TO DESIRED LENGTH)

RIGHT LEG - DETAIL A: CREATE TAB BY CUTTING TOP FLANGE AT ANGLE 2 7/8" AS SHOWN. CUT 1/8" DOWN FACE AND 1" HORIZONTALLY. CUT DOWNWARD THROUGH FACE AND CONTINUE CUTTING TO WITHIN 3/8" FROM BOTTOM FLANGE. CUT 1" HORIZONTALLY AS SHOWN, THEN CUT THROUGH BOTTOM FLANGE. BEND 1" TAB 90° OUTWARD AS SHOWN.

LEFT LEG : DETAIL B: TRIM BACK THE TOP FLANGE ON ANGLE 1 7/8". PROCEED CUTTING THROUGH FRONT FACE AS SHOWN.



Customer Service  
1-800-727-9872

DATE: 02/08/17  
DRN BY: JJC  
CKD BY: SAK

SHT.# 4 OF 5

DWG# 20110-25641

A



# DERBIGUM ONE EDGE

LAP JOINT VERSION

## INSTALLATION INSTRUCTIONS

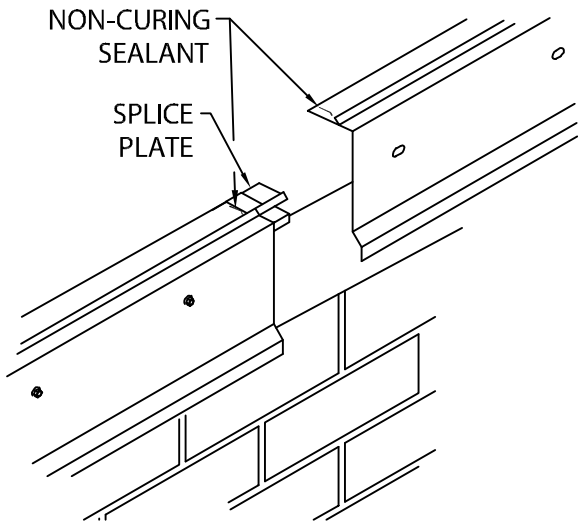

### STEP 9 - BASE RAIL INSTALLATION

CONTINUE WITH APPLICATION OF NON-CURING SEALANT TO ENDS OF 12'-0" BASE RAIL SECTIONS. INSTALL A BASE RAIL SPLICE PLATE ONTO THE END OF A RAIL SECTION TO THE HALFWAY POINT OF THE SPLICE PLATE FLANGE

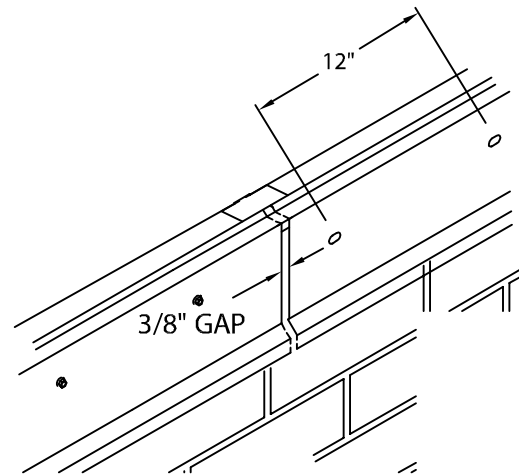

### STEP 10 - BASE RAIL INSTALLATION

INSTALL 12'-0" SECTION OF BASE RAIL FROM RIGHT TO LEFT AS SEEN FROM ROOF TOP. LEAVE A 3/8" GAP BETWEEN RAIL SECTIONS. FASTEN RAIL TO NAILER THROUGH RAIL SLOTS 12" O.C. WITH PROVIDED FASTENERS. FIELD CUT THE BASE RAIL SECTIONS AS NEEDED.

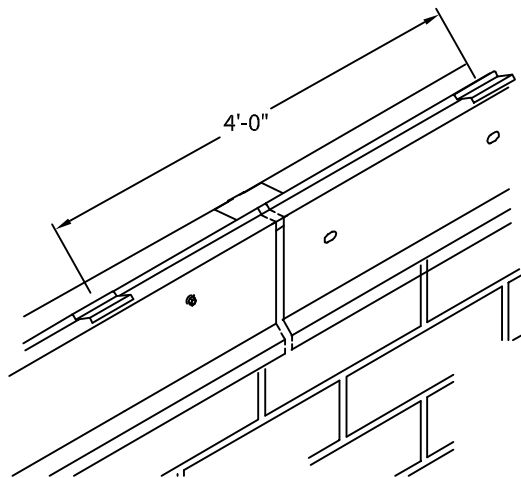

### STEP 11 - SPRING CLIPS

SET 6" WIDE STAINLESS STEEL SPRING CLIPS STARTING AT FASCIA COVER END AND EVERY 4'-0" O.C. ON THE INSTALLED BASE RAIL AS SHOWN.

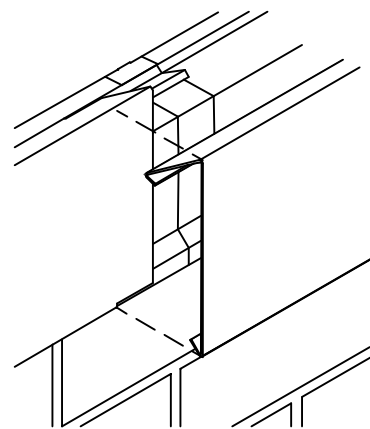

### STEP 12 - FASCIA COVER

REMOVE THE PROTECTIVE FILM FROM FASCIA COVERS. PLACE 12'-0" COVERS ON TOP OF BASE RAIL, LAPPING PRECEDING COVER 1", AGAIN INSTALLING RIGHT TO LEFT AS PER STEP 3. WHEN COVERS ARE IN POSITION, SNAP EACH COVER ONTO BASE RAIL BY PRESSING DOWN WITH THE PALM OF YOUR HAND UNTIL THE COVER IS FULLY ENGAGED ALONG THE ENTIRE LENGTH. FIELD CUT COVERS AS REQUIRED.



**DERBIGUM®**  
MAKING BUILDINGS SMART

Customer Service  
1-800-727-9872

DATE: 02/08/17  
DRN BY: JJC  
CKD BY: SAK

SHT.# 5 OF 5  
DWG# 20110-25641

**A**