

NOTES:

- ① ANCHOR CLIP PROFILE ON WALLS 14" AND GREATER.
- ② FACE = COVERAGE (SHOULD EXTEND A MIN. OF 1" BELOW WATERPROOFING MEMBRANE) + 1⁹/₁₆".
- ③ 24 GA. GALV. AND .040" ALUM. COPING COVERS AVAILABLE FOR WALL SIZES 3¹/₂" TO 24" ONLY.
- ④ WELDED ACCESSORIES REQUIRE A MINIMUM MATERIAL THICKNESS OF .050".
- ⑤ FOR NON 90° MITERS PLEASE USE PRINT APPROVAL #11011-1487.

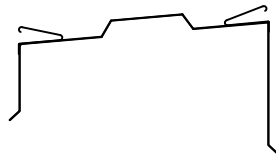

MATERIAL:

___ 24 GA. GALVANIZED STEEL ③ ___ .040" ALUMINUM ③
 ___ 22 GA. GALVANIZED STEEL ___ .050" ALUMINUM
 ___ OTHER _____ ___ .063" ALUMINUM
 COLOR: _____ FINISH: _____

QUANTITIES:

_____ LINEAL FEET 12'-0" LENGTHS

ACCESSORIES:

___ OUTSIDE MITERS @ 90° ⑤ SPECIFY ACCESSORY TYPE:
 ___ INSIDE MITERS @ 90° ⑤ WELDED ④
 ___ RIGHT ENDCAPS QUICKLOCK
 ___ LEFT ENDCAPS
 ___ RIGHT ENDWALL (COPING VERSION)
 ___ LEFT ENDWALL (COPING VERSION)
 ___ RIGHT ENDWALL (SPLICE PLATE VERSION)
 ___ LEFT ENDWALL (SPLICE PLATE VERSION)

AUTHORIZED SIGNATURE:

APPROVED BY: _____

DATE: _____



ANSI/SPRI ES-1 TESTED

PROJECT:

ARCHITECT:

ROOFING CONTRACTOR:

REPRESENTATIVE/DISTRIBUTOR:

CORPORATE OFFICES, MANUFACTURING
 1600 AIRPORT ROAD; WAUKESHA, WI 53188

PHONE: 800-558-2162
 FAX: 800-373-9156

WEBSITE: WWW.METALERA.COM
 EMAIL: QUOTE@METALERA.COM

DATE: 03/05/19
 DRN BY: ZS
 CKD BY: SAK

SHT.# ___ OF ___

DWG# 11011-19170

F

PERMA-TITE COPING

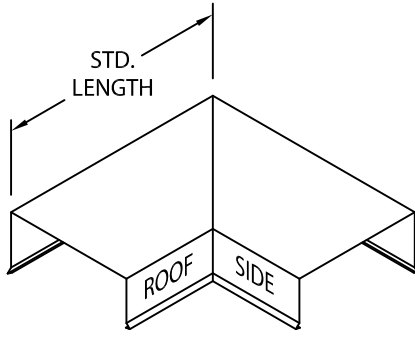

OUTSIDE MITER

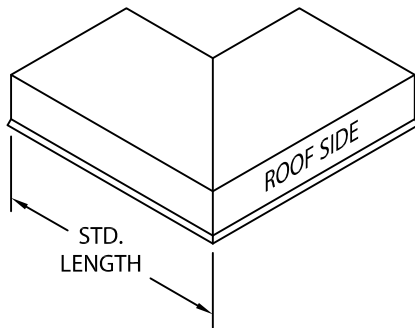

INSIDE MITER

MITER STANDARD LEG LENGTH:
WALL SIZE + 9⁵/₈" = LENGTH

PERMA-TITE COPING STANDARD ACCESSORIES

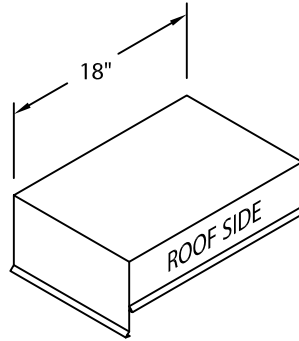

ENDCAP
(LEFT HAND SHOWN)

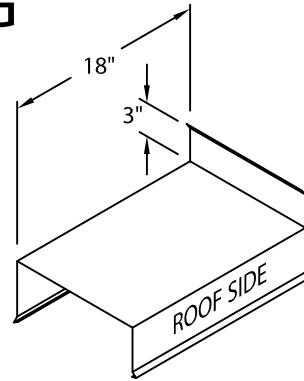

ENDWALL FLASHING
COPING VERSION
(RIGHT HAND SHOWN)

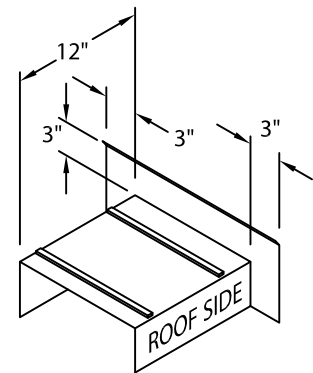

ENDWALL FLASHING
SPLICE PLATE VERSION
(RIGHT HAND SHOWN)
(AVAILABLE ONLY IN
.040" WELDED, PAINTED
TO MATCH COPING)

ADDITIONAL ACCESSORIES ARE AVAILABLE ON WEBSITE:

- TRANSITION MITERS
- STRAIGHT TRANSITION MITERS
- "T" MITERS
- "Z" MITERS
- STEP-UP MITERS
- PEAK / VALLEY MITERS
- PILASTER CAPS
- RADIUS COPING
- ARCHED COPING

(FOR ADDITIONAL ACCESSORY REQUIREMENTS, ATTACH SKETCHES OR CALL MANUFACTURER FOR ASSISTANCE).

ANCHOR CLIP SPACING:

- 24 GA. / .040", 16" WALL SIZE OR LESS, ANCHOR CLIPS ARE 48" O.C.
- 24 GA. / .040", OVER 16" WALL SIZE, ANCHOR CLIPS ARE 36" O.C.
- 22 GA. / .050" / .063", 26¹/₂" WALL SIZE OR LESS, ANCHOR CLIPS ARE 48" O.C.
- 22 GA. / .050" / .063", OVER 26¹/₂" WALL SIZE, ANCHOR CLIPS ARE 36" O.C.
- FLORIDA JOBS HAVE ANCHOR CLIPS 36" O.C. FOR ALL WALL SIZES.

ANCHOR CLIP MATERIAL IS 20 GA. GALV. FOR ALL WALL SIZES UP TO 26¹/₂".
16 GA. GALV. FOR ALL WALL SIZES GREATER THAN 26¹/₂"