

DOWNSPOUT TRANSITION

ISOMETRIC VIEW

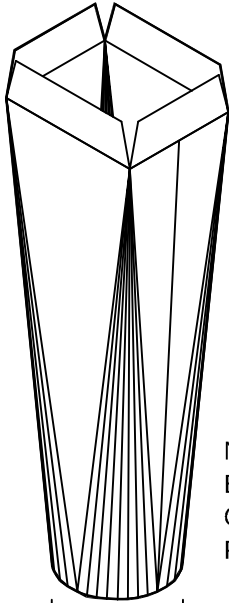

FRONT VIEW

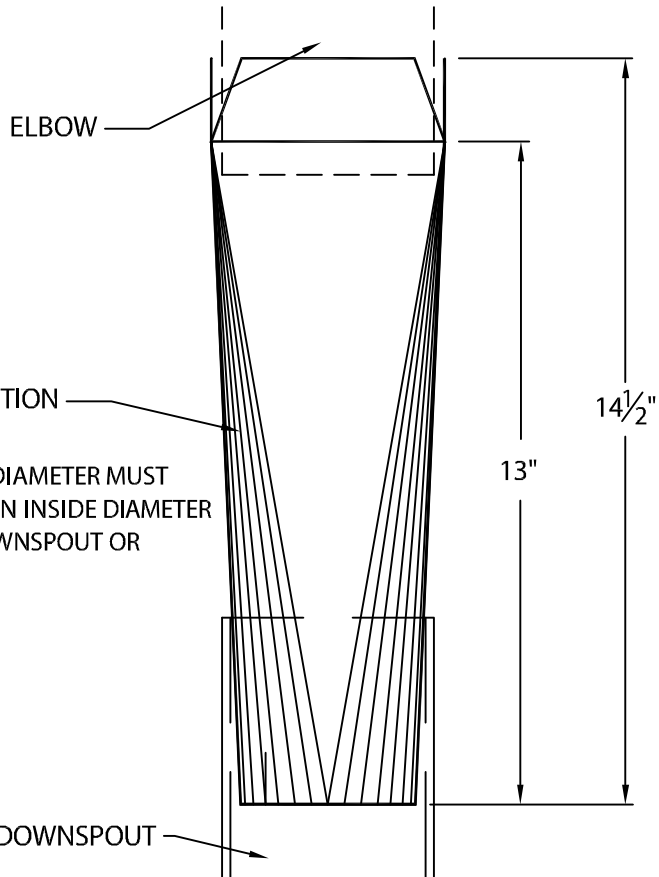

NOTE: OUTSIDE DIAMETER MUST BE SMALLER THAN INSIDE DIAMETER OF EXISTING DOWNSPOUT OR PVC PIPE

FRONT VIEW

SPECIFY OUTSIDE DIAMETER

EXISTING DOWNSPOUT

-- WELDED SEAM OR QUICKLOCK SEAM
 CHECK ONE WELDED QUICKLOCK

Fabrication will proceed only after receipt of signed print approval.

Print Approval:

Architect and/or contractor shall verify all dimensions, sizes and quantities. All products to be installed in strict accordance with Metal-Era's printed instructions.

Approved by: _____

Date: _____

MATERIAL:

__ 24 GA. GALVANIZED STEEL __ .050" ALUMINUM

__ .040" ALUMINUM __ .063" ALUMINUM

__ OTHER : _____

COLOR: _____ FINISH: _____

QUANTITIES:

_____ AMOUNT REQUIRED*

DOWNSPOUT SIZE _____" x _____"

*WELDED VERSION WITH QUANTITIES OVER 15 REQUIRE AN EXTENDED LEAD TIME DUE TO POST COATING PROCESS.

PROJECT: _____

ARCHITECT: _____

ROOFING CONTRACTOR: _____

REPRESENTATIVE/DISTRIBUTOR: _____

Corporate Offices, Manufacturing
 1600 Airport Road; Waukesha, WI 53188
 Phone: 800-558-2162
 Fax: 800-373-9156
 www.metalera.com



DATE: 11/23/16 SHT.# ____ OF ____

DRN BY: JJC

CKD BY: SAK DWG# 11013-1309 **D**