



ELEVATE GOLD COPING

TAPERED VERSION - 3'-0" O.C.

INSTALLATION INSTRUCTIONS

IMPORTANT: PRIOR TO INSTALLATION, READ INSTRUCTIONS CAREFULLY.

NOTE: POSITION ROOF MEMBRANE ON TOP OF THE WALL COVERING THE TREATED WOOD NAILER(S) OR SUBSTRATE COMPLETELY. ALLOW 1/2" MINIMUM EXCESS MEMBRANE BEYOND NAILER WHERE APPLICABLE. NRCA REQUIREMENT.

CAUTION: INSTALL MITERS FIRST!

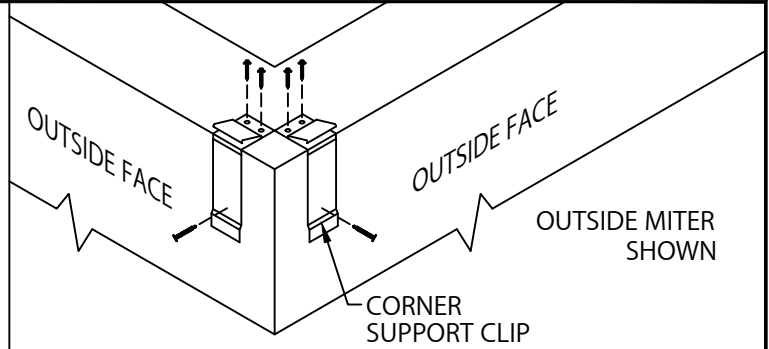

STEP 1 - CORNER SUPPORT CLIPS
LOCATE AND FASTEN GALVANIZED CORNER SUPPORT CLIPS TO THE WALL.

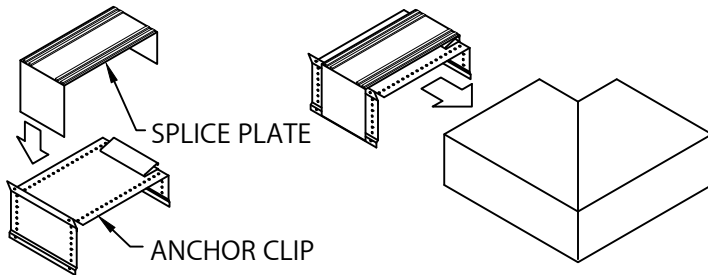

STEP 2 - MITER SPLICE PLATES & ANCHOR CLIPS

REMOVE RELEASE PAPER FROM SPLICE PLATE SEALANT STRIPS. POSITION THE SPLICE PLATE IN THE CENTER OF THE ANCHOR CLIP. INSTALL THE SPLICE PLATE AND ANCHOR CLIP ASSEMBLY INTO EACH END OF THE CORNER AS SHOWN.

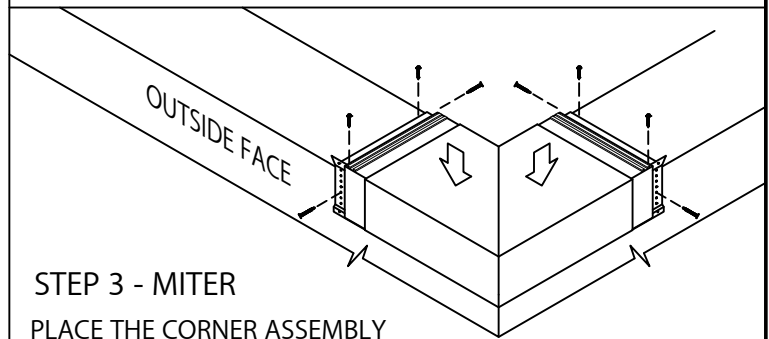

STEP 3 - MITER
PLACE THE CORNER ASSEMBLY INTO POSITION AND SECURE AT THE EXPOSED EDGE OF THE ANCHOR CLIPS AS PER DETAIL A.

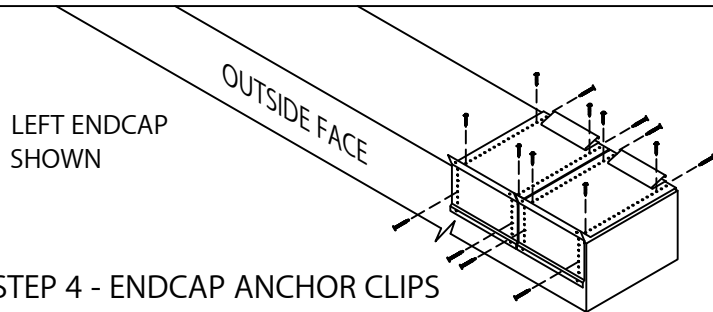

STEP 4 - ENDCAP ANCHOR CLIPS
LOCATE AND FASTEN GALVANIZED ANCHOR CLIPS TO WALL WITH PROVIDED FASTENERS FOR SUBSTRATE (SEE DETAIL A).

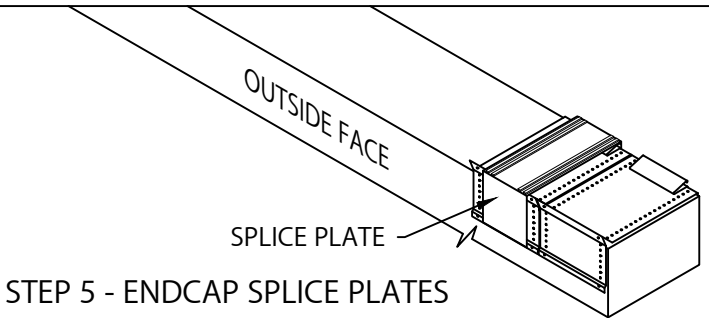

STEP 5 - ENDCAP SPLICE PLATES
REMOVE RELEASE PAPER FROM TOP OF FACTORY APPLIED SEALANT STRIPS. PLACE SPLICE PLATE ONTO SECOND ANCHOR CLIP AS SHOWN.

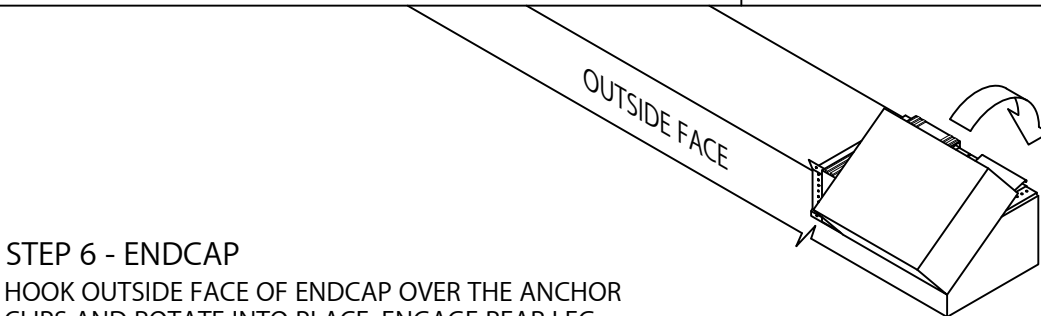

STEP 6 - ENDCAP
HOOK OUTSIDE FACE OF ENDCAP OVER THE ANCHOR CLIPS AND ROTATE INTO PLACE. ENGAGE REAR LEG ONTO ANCHOR CLIPS BY PRESSING DOWNWARD UNTIL SNAP LOCK OCCURS.



ELEVATE
26 CENTURY BLVD.
SUITE 205
NASHVILLE, TN 37214

CONTACT YOUR LOCAL ELEVATE REPRESENTATIVE

DATE: 04/17/23
DRN BY: MLM
CKD BY: MM

SHT.# 1 OF 3

DWG# 13111-33183





ELEVATE GOLD COPING

TAPERED VERSION - 3'-0" O.C.

INSTALLATION INSTRUCTIONS

INSTALLATION NOTES:

- 1) Installing contractor shall check as-built conditions, including nailer attachment, and verify the manufacturer's coping details for accuracy to fit the wall assembly prior to fabrication.
- 2) Fasteners must be corrosion resistant and rated for a minimum 250# pullout force for the substrate that is being used.

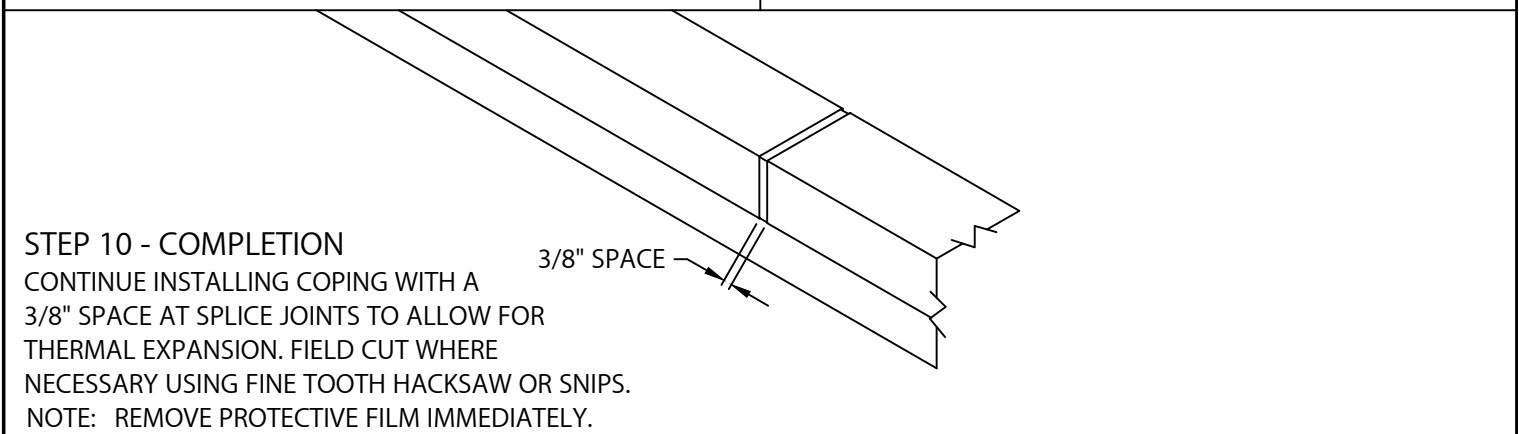
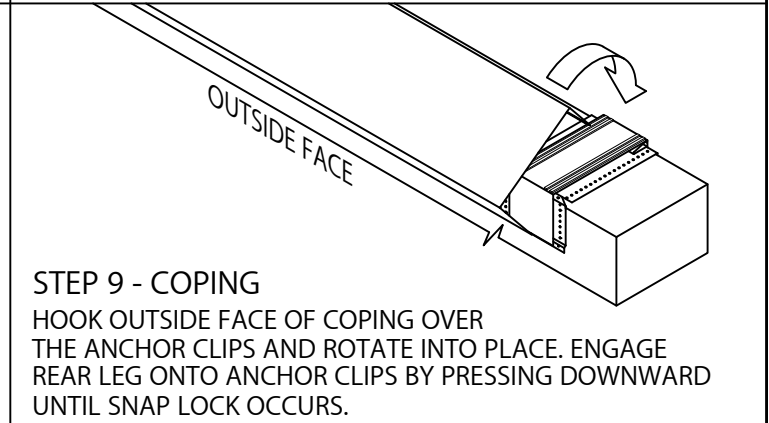
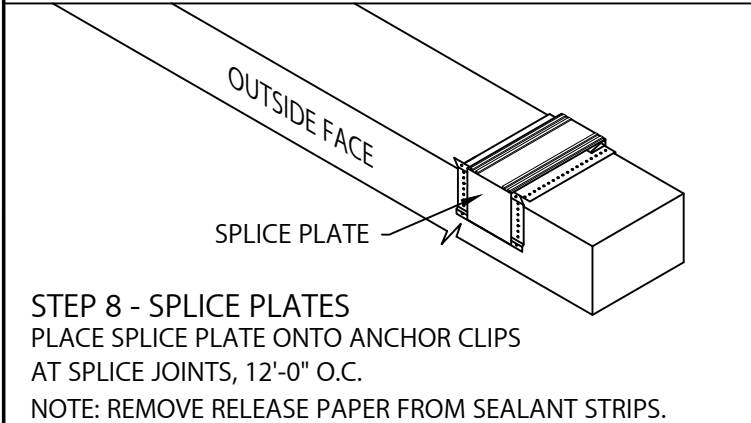
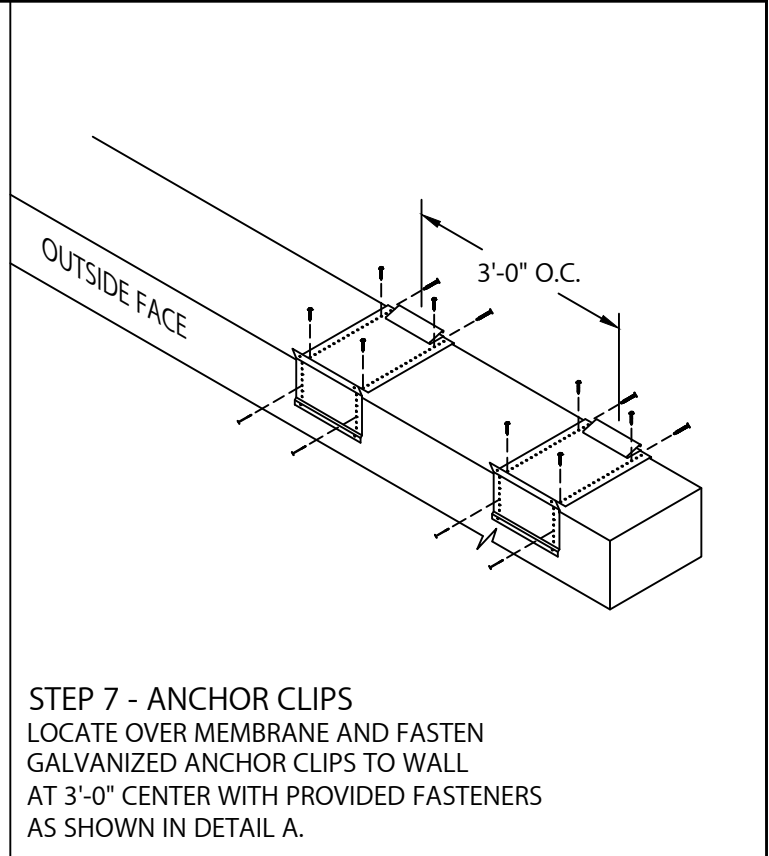
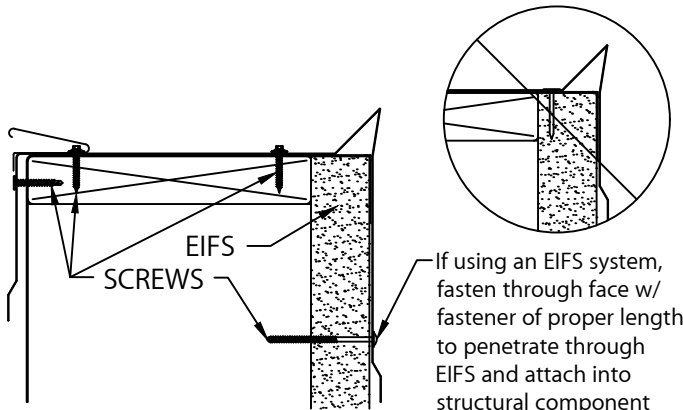

ELEVATE
26 CENTURY BLVD.
SUITE 205
NASHVILLE, TN 37214
CONTACT YOUR LOCAL ELEVATE REPRESENTATIVE

DATE: 04/17/23
DRN BY: MLM
CKD BY: MM

SHT.# 2 OF 3
DWG# 13111-33183

D



ELEVATE GOLD COPING

TAPERED VERSION - 3'-0" O.C.

INSTALLATION INSTRUCTIONS

TYPICAL COPING INSTALLATION DETAIL A

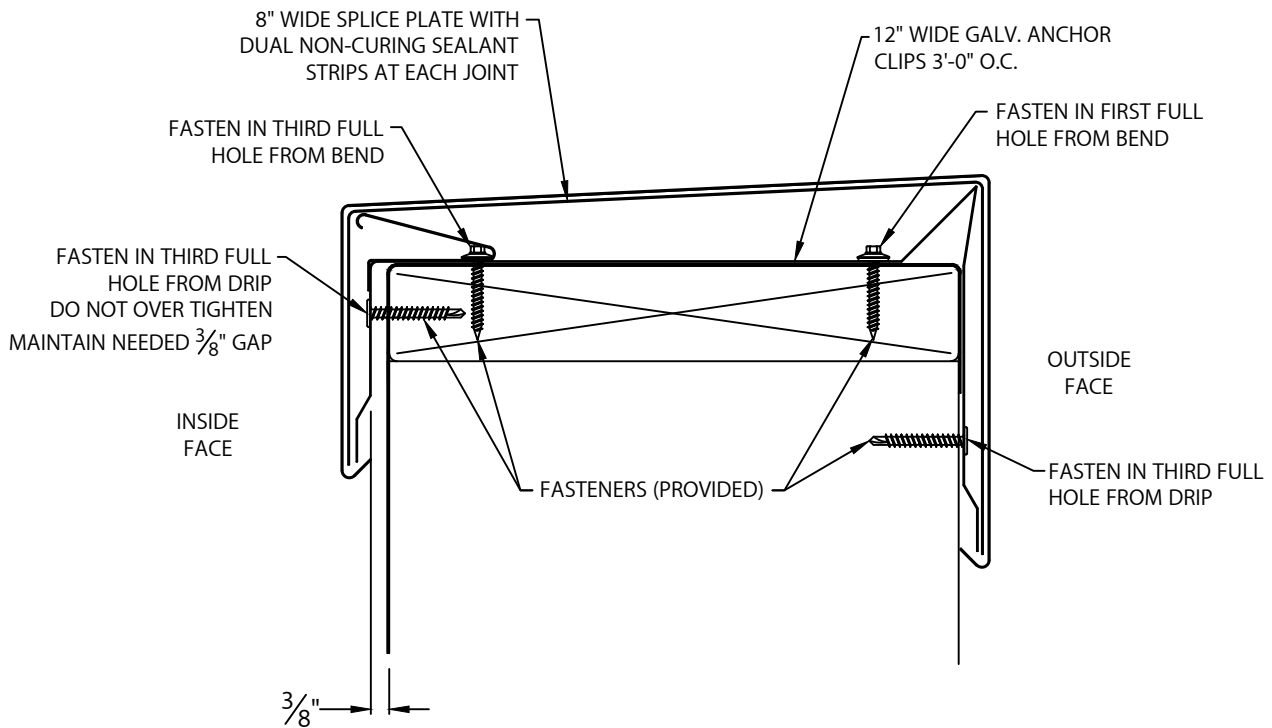

ELEVATE
26 CENTURY BLVD.
SUITE 205
NASHVILLE, TN 37214
CONTACT YOUR LOCAL ELEVATE REPRESENTATIVE

DATE: 04/17/23
DRN BY: MLM
CKD BY: MM

SHT.# 3 OF 3

DWG# 13111-33183

D