

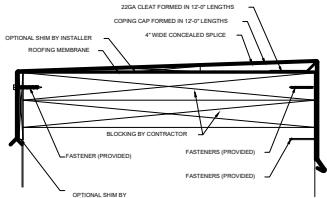

Installation Guide for VersiTrim One Coping

PO BOX 1289, CARLISLE, PA 17013 USA
800-992-766
WWW.VERSICO.COM

Installation Guide for VersiTrim One Coping



NOTES:

#1 - Isolate all metal parts from ACQ treated wood or other galvanically incompatible material with appropriate membrane material.

#2 - Appliance attachments, such as lightning rods, signs, or antennae that penetrate the edge system, induce a galvanic reaction, or otherwise compromise the effectiveness of the roof edge system, shall be eliminated or isolated to prevent problems per ANSIS/SPRI/FM4435/ES-1. Lightning protection systems for example must not be directly affixed to the product provided by the manufacturer.

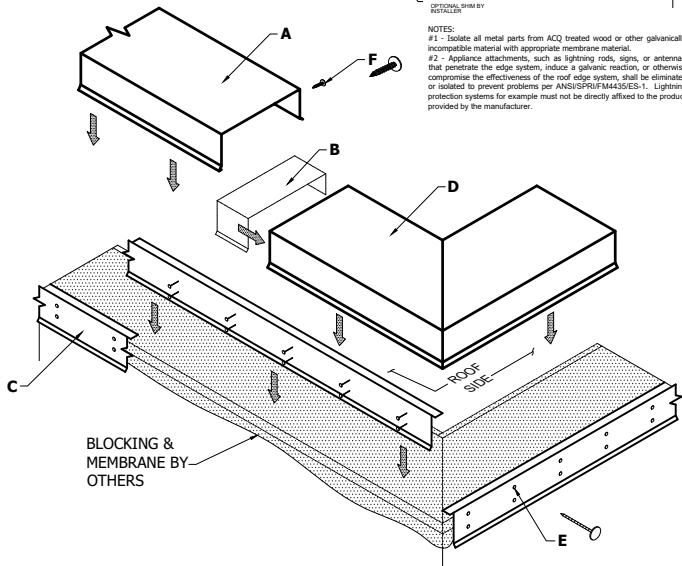

A. Coping Cap

12'-0" Lengths

B. Concealed Joint Splice

4" Wide at Each Coping Cap Joint

C. Galvanized Steel Cleat

12'-0" Lengths

D. Coping Miter Cap

(Outside Corner Shown)

E. Fastener

6" from ends, 12" o.c.
(Included & Required)

F. Fastener w/ Washer

at 12" o.c. into pre-punched holes
(Included & Required)

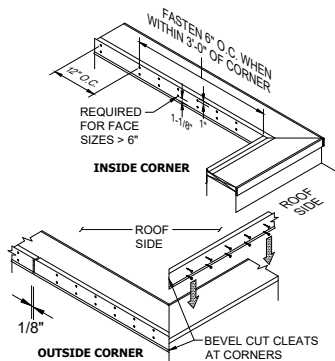

STEP 1: Installing Cleat

Prior to installing the cleat, ensure that all metal components have been isolated from ACQ treated lumber with appropriate membrane material. Field cut cleat to fit corner conditions. Install cleat working away from corners. Allow 1/8" gap between sections for thermal movement. Press cleats securely in position and fasten through the cleat using fasteners provided at the locations shown above and at 12" O.C.; 6" O.C. when fastening within 3'-0" of corners. The lower row of fasteners are required for face sizes > 6" or for wall widths > 16".

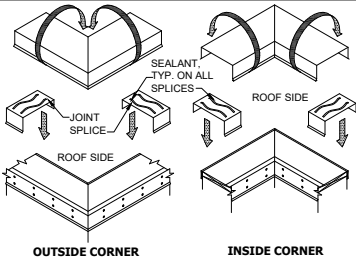

STEP 2: Installing Coping Miters

Locate the miter for the appropriate corner. Place a joint splice on the wall at each end of the coping miter (approx. half way covered by the coping miter). Seal all cap-to-splice junctions with non-hardening sealant (by installer). Do not fasten joint splices. Hook the drip of the coping miter over the kick out of the cleat, rotate the coping miter over the top of the parapet and secure the roof side leg of the coping @ 12" o.c. w/ threaded fasteners provided.

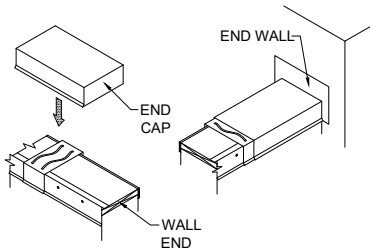

STEP 3: Installing End Caps and End Walls

Install end caps and end walls by hooking the drip over the kick out and rotating the cap over the parapet. End caps and end walls must be restrained from moving by securing with a min. of (2) screws through the roof side leg. Apply sealant at all joints.

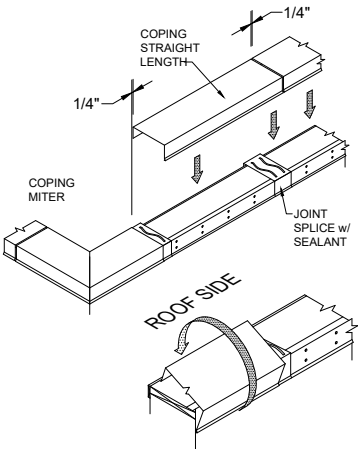

STEP 4: Installing Coping Straight Lengths

Begin installing from the corners and ends working inward to the center. Allow a 1/4" gap between the coping sections for thermal expansion. Fasten the roof side leg of the coping at the pre-punched holes (12" o.c.) using threaded fasteners provided. Review lengths of all straight pieces prior to cutting to avoid creating relatively short sections of cap adjacent to full length sections. Seal all joints between coping cap and joint splices using non-hardening sealant.