

# INDUSTRIAL EXTERNAL GUTTER BRACKET

IG-2 VERSION

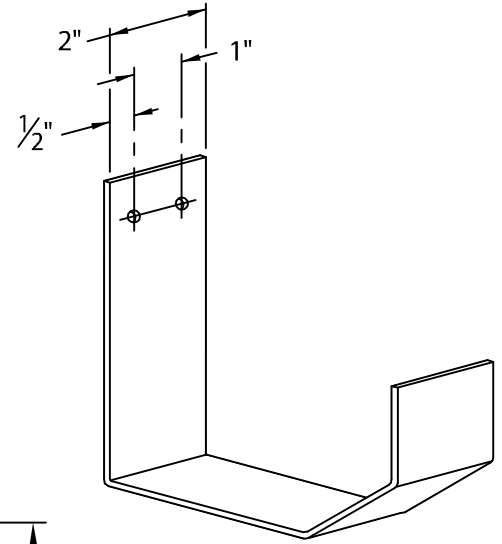
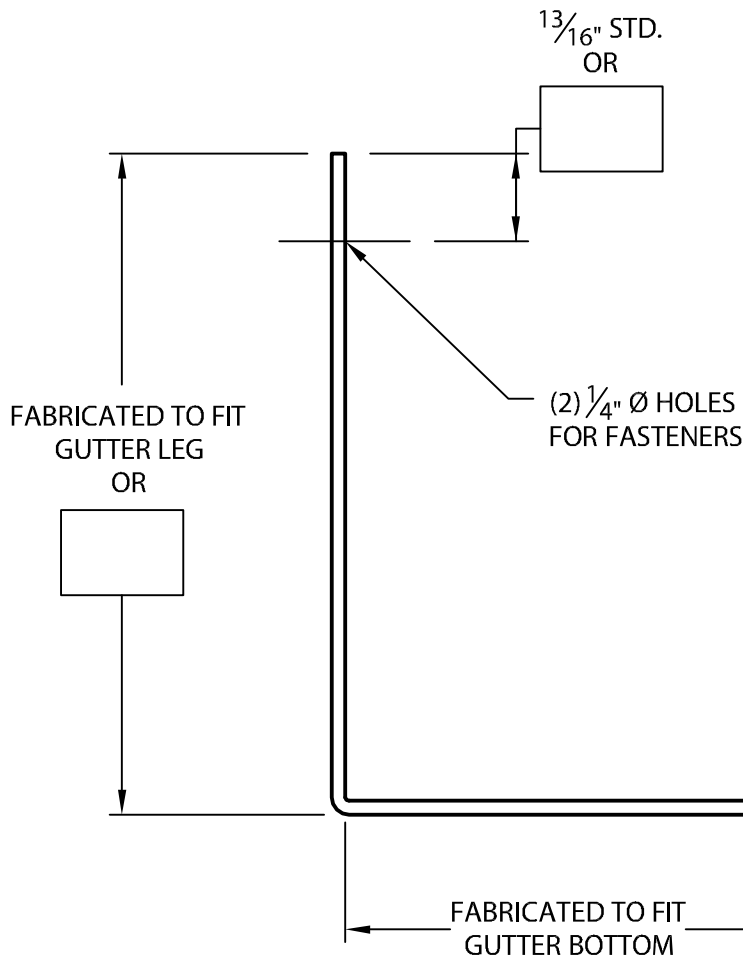

ISOMETRIC VIEW

2" WIDE BRACKET

Fabrication will proceed only after receipt of signed print approval.

## Print Approval:

Architect and/or contractor shall verify all dimensions, sizes and quantities. All products to be installed in strict accordance with Carlisle SynTec, Inc.'s printed instructions.

Approved by: \_\_\_\_\_

Date: \_\_\_\_\_

## MATERIAL:

.125" ALUMINUM

COLOR: \_\_\_\_\_

FINISH: \_\_\_\_\_

## QUANTITIES:

\_\_\_\_\_ AMOUNT REQUIRED\*

\*QUANTITIES OVER 200 REQUIRE AN EXTENDED LEAD TIME DUE TO POST COATING PROCESS.

PROJECT:

ARCHITECT:

ROOFING CONTRACTOR:

REPRESENTATIVE/DISTRIBUTOR:

Customer Service  
866-458-3537  
(Metal-Era)



DATE: 03/04/16

DRN BY: JJC

CKD BY: SAK

SHT.# \_\_\_ OF \_\_\_

DWG# 15012-1734

C