



ONE FLASH-THRU DRIP EDGE

6" MAX. FACE HEIGHT, BUILT-UP OR MODIFIED VERSION WITH CONTINUOUS CLEAT

ANSI/SPRI ES-1 DESIGN PRESSURE OF 276 psf

5/32" x 1/2" SLOTTED HOLES STAGGERED 6" O.C.

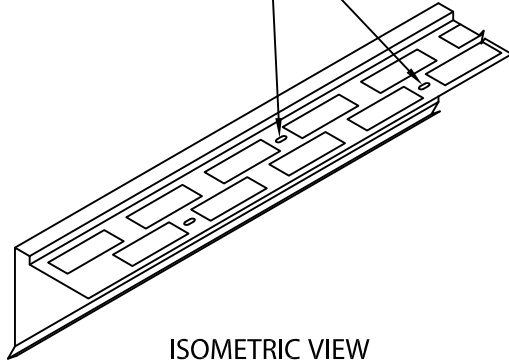

ISOMETRIC VIEW

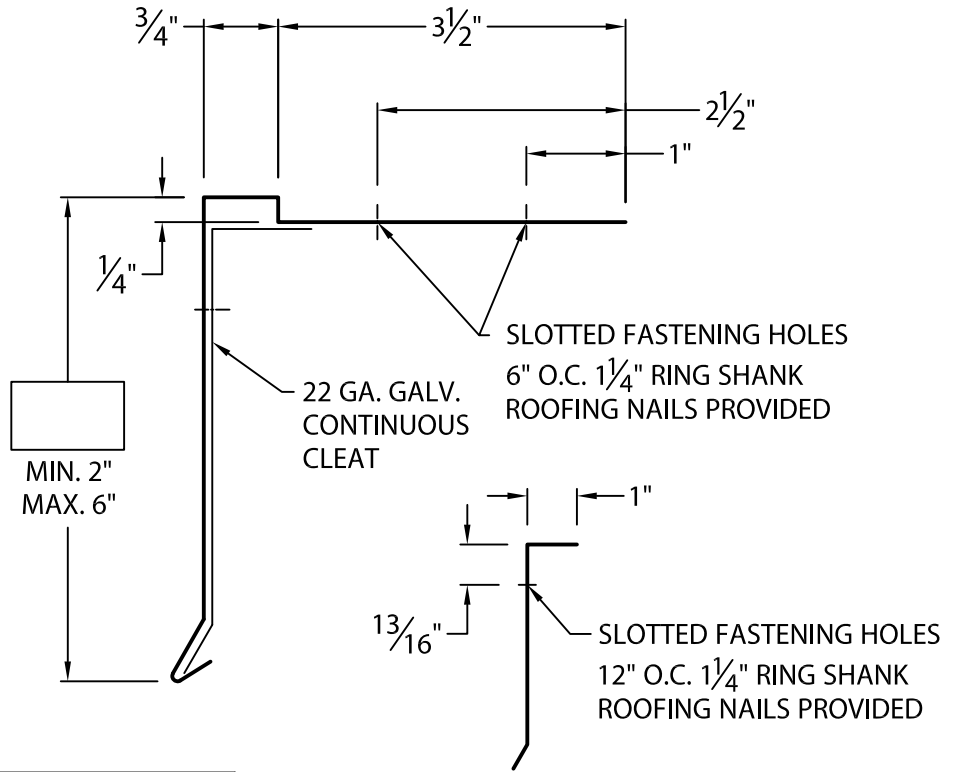

CLEAT DETAIL

NOTES:

- INCLUDES 6" WIDE CONCEALED SPLICE PLATES.
- CONCEALED SPLICE PLATE MUST BE FIELD CAULKED TO PREVENT WATER ENTRY.
- UNLESS OTHERWISE NOTED, FABRICATION OF MITERS AND ACCESSORIES ARE FURNISHED STANDARD UTILIZING A NON-PENETRATING QUICKLOCK JOINT, THEN FACTORY SEALED WATERTIGHT.

Fabrication will proceed only after receipt of signed print approval.

Print Approval:

Architect and/or contractor shall verify all dimensions, sizes and quantities. All products to be installed in strict accordance with Metal-Era's printed instructions.

Approved by: _____

Date: _____

WELDED MITERS AND ACCESSORIES

CHECK ONE REQUIRED (SURCHARGE) NOT APPLICABLE

MATERIAL:

- ___ 24 GA. GALVANIZED STEEL
- ___ .040" ALUMINUM COLOR: _____
- ___ .050" ALUMINUM
- ___ .063" ALUMINUM FINISH: _____
- ___ OTHER _____

QUANTITIES:

- _____ LINEAL FEET (12'-0" LENGTHS)
- _____ OUTSIDE MITERS @ 90°
- _____ INSIDE MITERS @ 90°

FOR NON-90° MITERS SEE PRINT APPROVAL #11010-1103

PROJECT:

ARCHITECT:

ROOFING CONTRACTOR:

REPRESENTATIVE/DISTRIBUTOR:

Corporate Offices, Manufacturing
1600 Airport Road; Waukesha, WI 53188
Phone: 800-558-2162
Fax: 800-373-9156
www.metalera.com



DATE: 09/25/18

DRN BY: JJC

CKD BY: SAK

SHT.# ___ OF ___

DWG# 11010-21139

H