

PRESTO-LOCK WELDED RADIUS COPING

OVER 6" TO 12" FACE HEIGHT TAPERED VERSION

IMPORTANT!!! MUST INDICATE PROPER RADIUS CONDITION BY CIRCLING APPROPRIATE OUTSIDE FACE

PROVIDING A RADIUS
THE RADIUS MAY BE PROVIDED
IN ONE OF TWO METHODS:

1.) THE ACTUAL KNOWN RADIUS IS



OR

2.) FIELD CONDITION MEASUREMENTS

NOTE: REFER TO ATTACHED WORKSHEET
FOR FURTHER INFORMATION

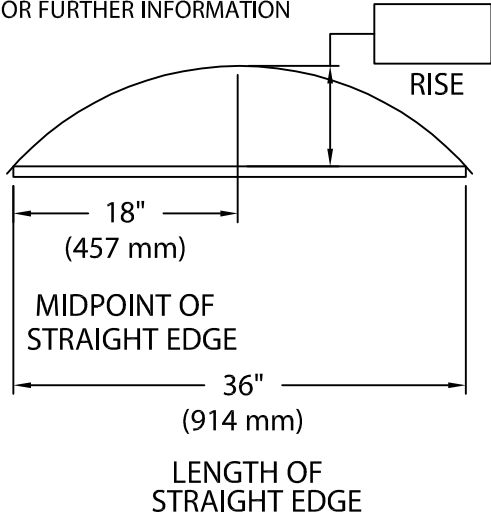

NOTE: CHECK MEASUREMENTS ALONG ENTIRE RADIUS.

DETAIL A

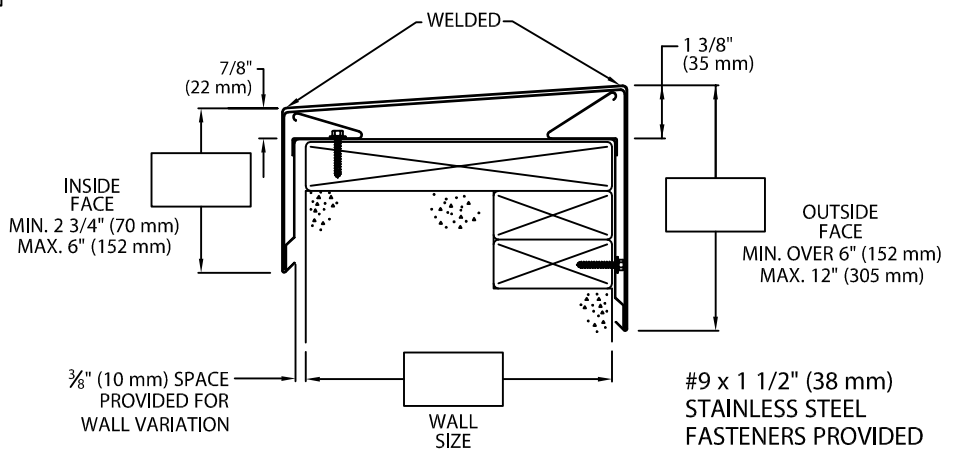
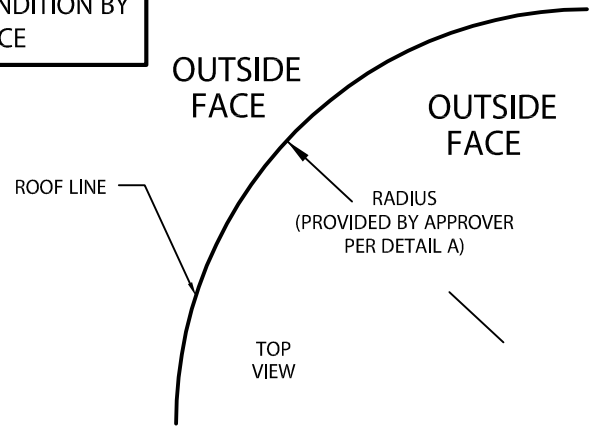

NOTES: -- Concealed splice plates are provided with factory applied dual non-curing sealant strips.

MATERIALS:

Top - .080" (2.03 mm) Alum.

Sides - .063" (1.60 mm) Alum.

Color: _____

Finish: _____

QUANTITIES:

_____ Lineal Feet 4'-0" (1.22 m) Lengths

Fabrication will proceed only after receipt of signed print approval.

Print Approval:

Architect and/or contractor shall verify all dimensions, sizes and quantities. All products to be installed in strict accordance with Johns Manville's printed instructions.

Approved by: _____

Date: _____

PROJECT:

ARCHITECT:

ROOFING CONTRACTOR:

REPRESENTATIVE/DISTRIBUTOR:

51 Lexington Street; Lewiston, ME 04240
CUSTOMER SERVICE: 800-223-8317 USA
800-445-1500 Canada
TECHNICAL SERVICE: 800-445-1500 USA & Canada
FAX: 207-784-0125
OTHER AREAS CALL: 207-784-0123



DATE: 01/05/10

DRN BY: JJC

CKD BY: SAK

SHT.# ____ OF ____

DWG# 16011-11182

A