

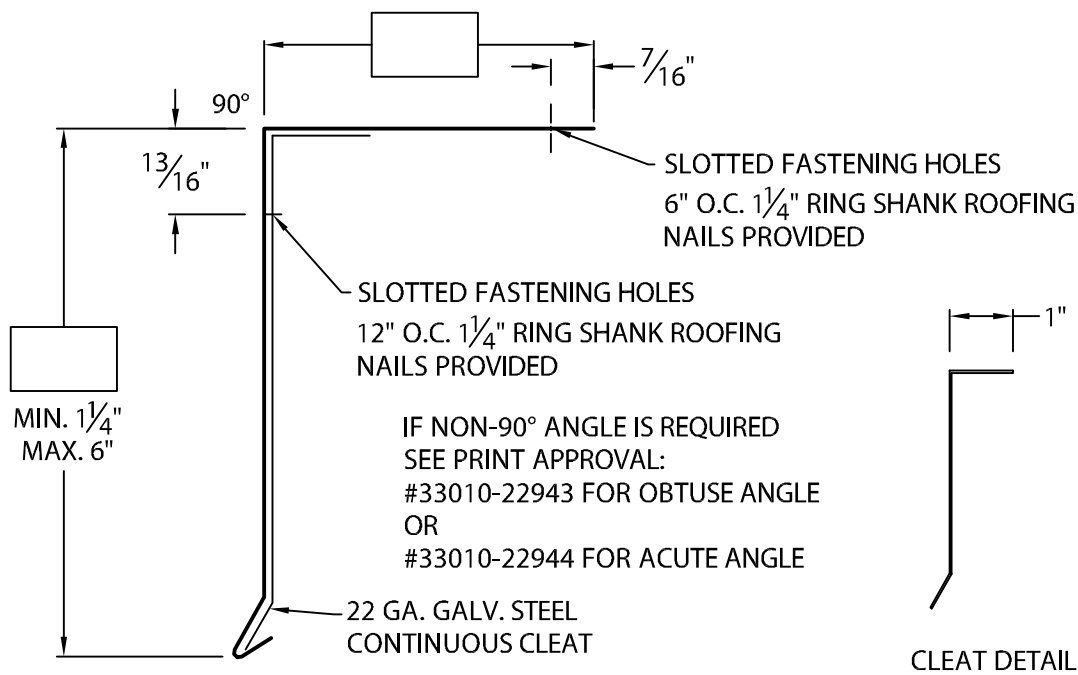

SOPREMA MODIFIED DRIP EDGE

1 1/4" TO 6" FACE HEIGHT WITH CONTINUOUS CLEAT VERSION

ANSI/SPRI/FM 4435/ ES-1 DESIGN PRESSURE OF 282 psf



NOTES:

- INCLUDES 6" WIDE CONCEALED SPLICE PLATES.
- CONCEALED SPLICE PLATES MUST BE FIELD CAULKED TO PREVENT WATER ENTRY.
- UNLESS OTHERWISE NOTES, FABRICATION OF MITERS AND ACCESSORIES ARE FURNISHED STANDARD UTILIZING A NON-PENETRATING QUICKLOCK JOINT, THEN FACTORY SEALED WATERTIGHT.

Fabrication will proceed only after receipt of signed print approval.

Print Approval:

Architect and/or contractor shall verify all dimensions, sizes and quantities. All products to be installed in strict accordance with SOPREMA's printed instructions.

Approved by: _____

Date: _____

FOR FACE SIZES OVER 6" SEE PRINT APPROVAL #41010-12235

-- WELDED MITERS AND ACCESSORIES

CHECK ONE REQUIRED (SURCHARGE) NOT APPLICABLE

MATERIAL:

____ 24 GA. GALVANIZED STEEL

____ .040" ALUMINUM COLOR: _____

____ .050" ALUMINUM FINISH: _____

____ .063" ALUMINUM

____ OTHER _____

QUANTITIES:

_____ LINEAL FEET 12'-0" LENGTHS

_____ OUTSIDE MITERS @ 90°

_____ INSIDE MITERS @ 90°

FOR NON 90° MITERS SEE PRINT APPROVAL #33010-20199

PROJECT:

ARCHITECT:

ROOFING CONTRACTOR:

REPRESENTATIVE/DISTRIBUTOR:

800-356-3521

www.soprema.us

310 Quadral Dr. Wadsworth, OH 44281

f: 330-334-6257



DATE: 01/09/17

DRN BY: JJC

CKD BY: SAK

SHT.# ____ OF ____

DWG# 33010-22942

C