

INDUSTRIAL DOWNSPOUT

CLOSED DOWNSPOUT, STYLE 2 DOWNSPOUT STRAP VERSION

INSTALLATION INSTRUCTIONS

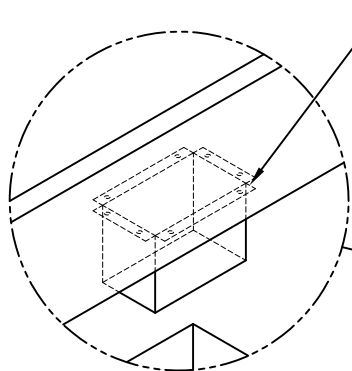

DETERMINE OUTLET LOCATIONS AND FIELD CUT HOLE IN A NEAT WORKMANLIKE MANNER. INSERT ALUMINUM KYNAR OUTLET, FASTEN WITH TWO RIVETS IN EACH FLANGE AND SEAL, WITH NON-CURING SEALANT

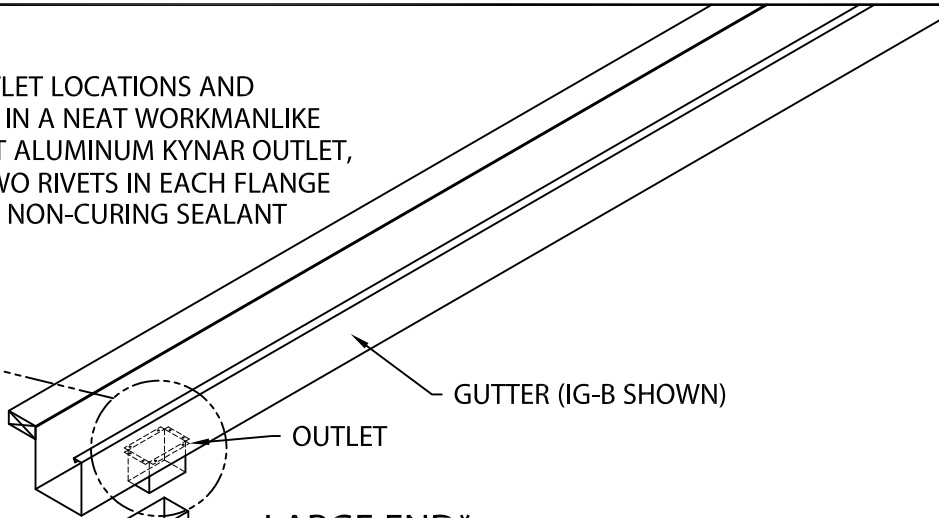

GUTTER (IG-B SHOWN)

OUTLET

LARGE END*

STANDARD ELBOW (STYLE A SHOWN)

SMALL END*

LARGE END*

DOWNSPOUT (12'-0" LENGTHS)

STYLE 2 DOWNSPOUT STRAPS
2" WIDE
TYPICAL 3 PER 12'-0" LENGTH
OF DOWNSPOUT. MOUNTED
IN FRONT OF DOWNSPOUT

SMALL END*

* TO DETERMINE WHICH END IS THE LARGE END AND WHICH END IS THE SMALL END, THE DOWNSPOUT WILL NEED TO BE MEASURED. AS AN EXAMPLE, ON A 4" x 6" DOWNSPOUT THE LARGE END WOULD BE 4" x 6" AND THE SMALL END WOULD BE 3⁷/₈" x 5⁷/₈".

DOWNSPOUT SECTION

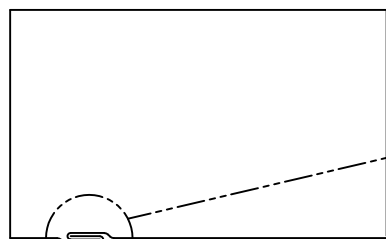

DOWNSPOUT
SNAP LOCK SEAM

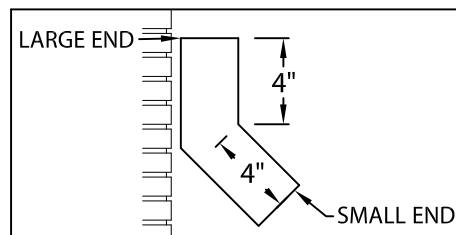

STYLE A DOWNSPOUT

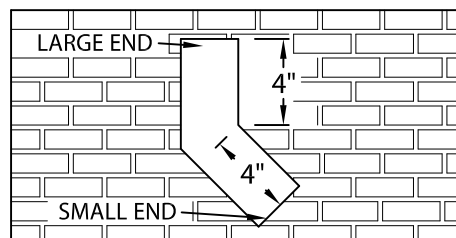

STYLE B DOWNSPOUT