

For Use With Modified Roof Systems

1. Roof Membrane

Follow the general recommendations of the roofing membrane manufacturer for membrane treatment at the roof edge. Position modified membrane over the roof edge and down the outside face as shown.

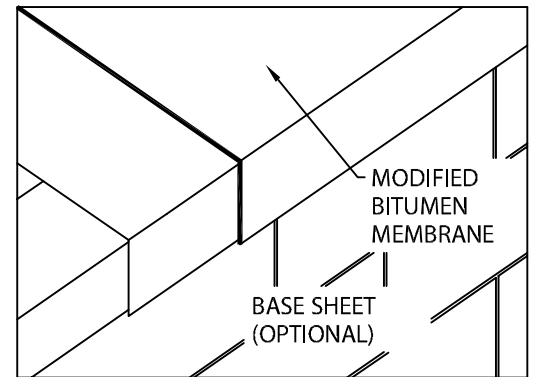

NOTE: Some manufacturers may require a "sacrificial" flashing strip. (Refer to drawing 2A & 2B) Please check with membrane manufacturer prior to installation.

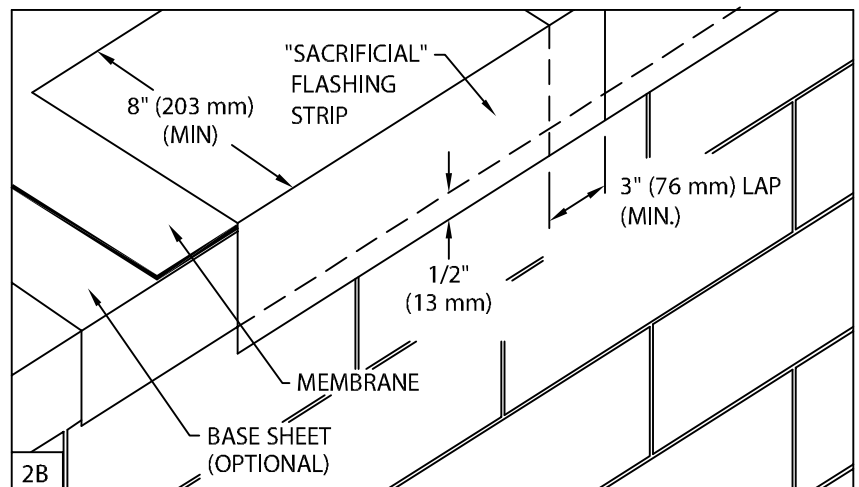
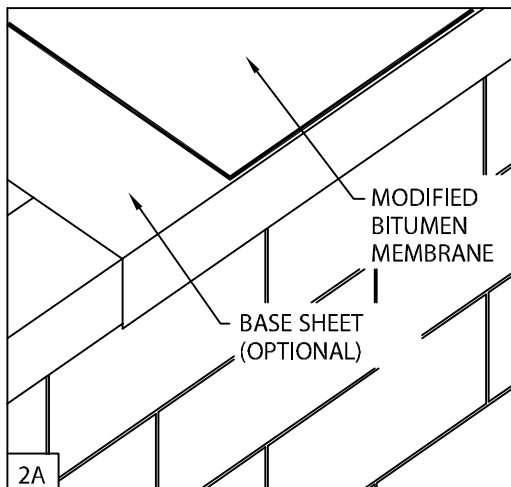

2. Roof Edge

Install "sacrificial" flashing strips according to membrane manufacturers recommendations. Install the largest manageable lengths possible to minimize overlaps under the anchor bar. Following the applicable flashing method (hot mop, cold adhesive, etc..) according to the manufacturer's recommendations, lay the flashing strip into place extending a minimum 8" (203 mm) onto the roof membrane and down the outside face of wall, 1/2" (13 mm) beyond the wood nailer.

NOTE: In cold weather, the back of flashing strip should be treated appropriately and shorter lengths of flashing strips should be used.



DESIGNER BULLNOSE FASCIA

BUILT-UP OR MODIFIED VERSION

INSTALLATION INSTRUCTIONS

For Use with Built-Up Roof Systems

1. Roof Membrane

Prior to the application of the Anchor-Tite Fascia, it is suggested that the contractor follow the common recommended industry practice of installing an "envelope" over the ends of the base or B.U.R. plies. As always, follow the general recommendations of the roofing membrane manufacturer for membrane treatment at the roof edge.

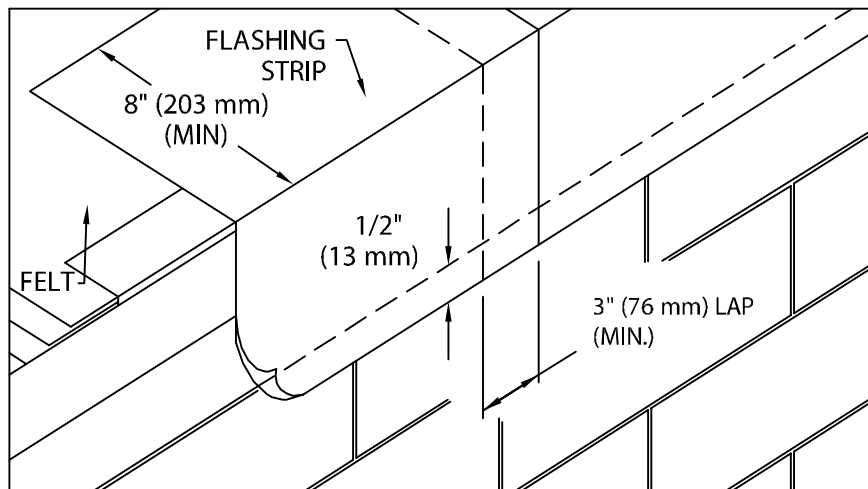
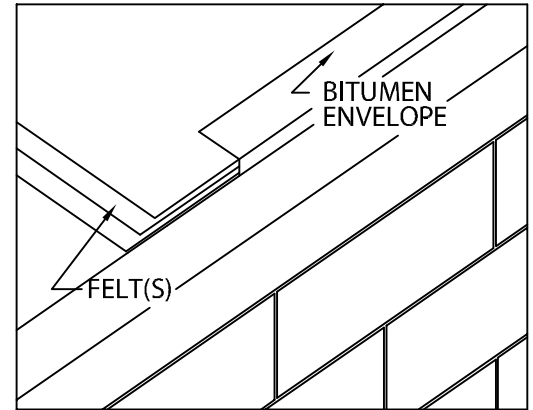

2. Roof Edge

Cut flashing strip into the longest possible sections manageable to minimize laps at the edge. Starting at outside edge, mop surface of felts out onto the roof membrane with Type III or IV asphalt. Lay the flashing strip into place over the roof edge extending 1/2" (13 mm) below nailer and onto the roof membrane a minimum of 8" (203 mm) . The sheet should be "worked-in" to ensure that it is firmly and uniformly bonded. In cool or cold weather, the back of flashing strip should also be mopped with the hot bitumen, and shorter lengths of flashing strips should be used. Laps in the flashing strip should be a minimum of 3" (76 mm) and well sealed.

NOTE! Flashing strip is material used in construction of traditional flashing systems on built-up roofs. It readily conforms to transitions at the outside edge and wall area. (Follow general recommendations of the roofing membrane manufacturer.)



Phone: 800-558-2162
Fax: 800-373-9156
www.metalera.com

DATE: 11/04/14
DRN BY: JJC
CKD BY: SAK

SHT.# 2 OF 5
DWG# 11110-1384

E

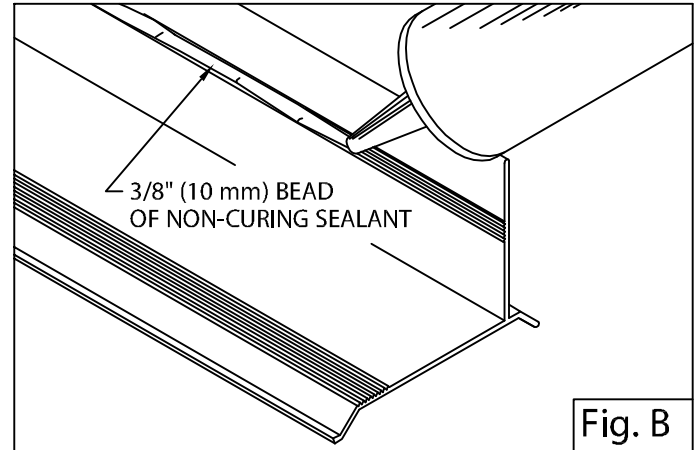
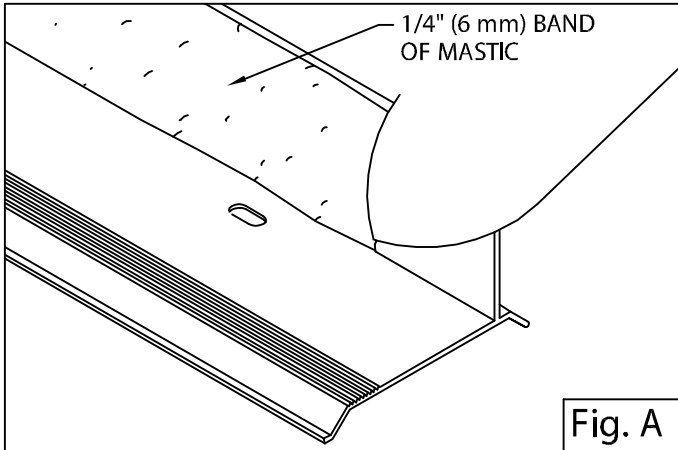

OPTIONAL INSTALL

3. Miter & Scupper Anchor Bar (Preparation)

Lay miters and spillout scuppers on deck with outside face down. Be sure aluminum anchor bar is clean and free of dirt or dust. Refer to Fig. A or B, depending on roofing manufacturer's recommendations. For Fig. A, Apply a 3" (76 mm) wide 1/4" (6 mm) thick band of mastic to the back of the anchor bar as shown. For Fig. B Apply a heavy 3/8" (10 mm) bead of non-curing sealant to the back of anchor bar as shown. Application of either type of mastic or sealant is required along the full length of each miter anchor bar.

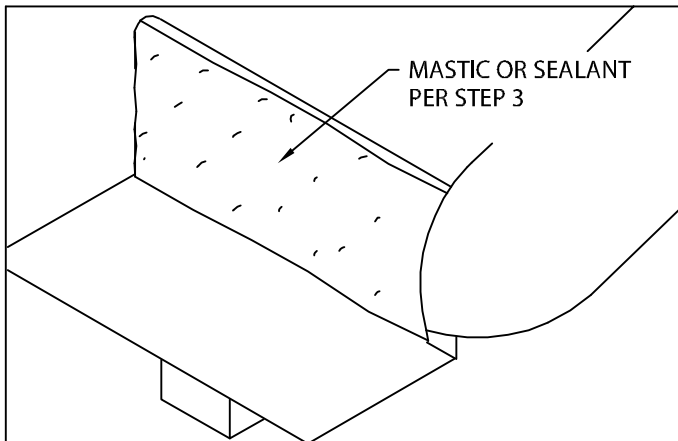

4. Anchor Bar Splice Plates

Apply mastic or sealant to each splice plate as shown and described in STEP 3.

CAUTION! Installers shall wear protective eyewear to prevent injury. Do not overdrive fasteners, as stripping can occur at high driver torque. Recommended Driving Tool: 600 - 800 rpm electric drill equipped with depth sensing nosepiece to prevent overdriving and stripout. Do not use impact type tool.

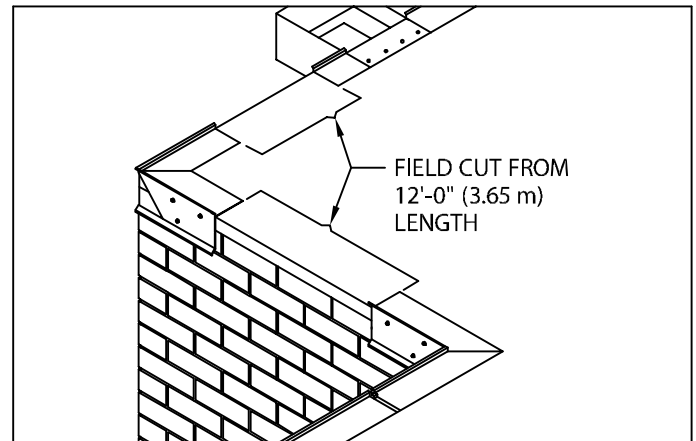

5. Miter Bar Installation

Install miters using 2" (51 mm) stainless steel fasteners and driver bit furnished by Metal-Era. Fasten anchor bar corners to nailer with one splice plate under each end of corner. The sponge gasket on each splice plate must be snug to ends of anchor bar. Next locate and install spillouts and scuppers with mastic or sealant 2" (51 mm) fasteners and splice plates.



DESIGNER BULLNOSE FASCIA

BUILT-UP OR MODIFIED VERSION

INSTALLATION INSTRUCTIONS

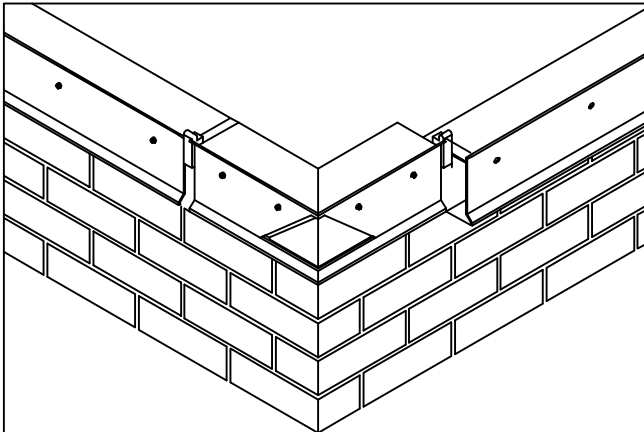

6. Anchor Bar (Installation)

Position 12'-0" (3.65 m) sections of anchor bar with applied mastic or sealant as shown in steps 3 & 4 overlapping splice plate and butting snugly into gasket. Allow 1/2" (13 mm) space between anchor bars. Install splice plate at other end of 12'-0" (3.65 m) bar. Fasten anchor bar 12" (305 mm) O.C. through slots using 2" (51 mm) stainless steel fasteners provided. Field cut sections as necessary.

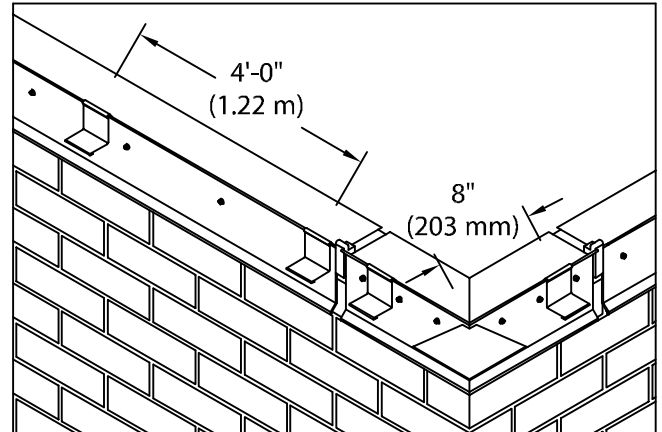

7. Support Clips

At miter sections, position support clips over anchor bar 8" (203 mm) from corner. Along straight runs, position support clips at each end of 12'-0" (3.65 m) anchor bar and 4'-0" (1.22 m) O.C. between.

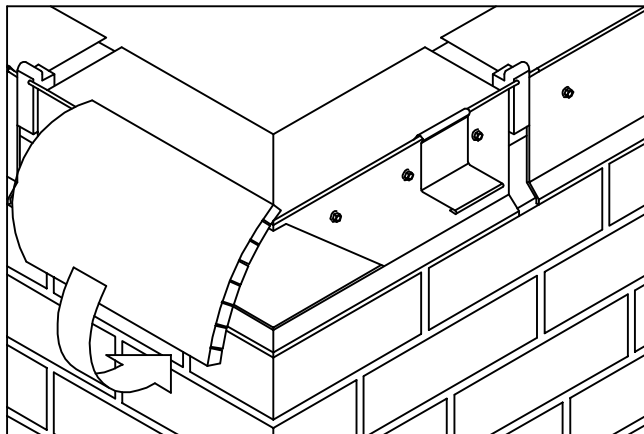

8. Miter Cover (Right Half)

Install right (tabbed) half of miter cover first. Place miter cover half over anchor bar with the face angled up to allow enough clearance past the support clip. Rotate cover into place. Engage cover to anchor bar by applying slight downward and inward pressure with palm of hand.

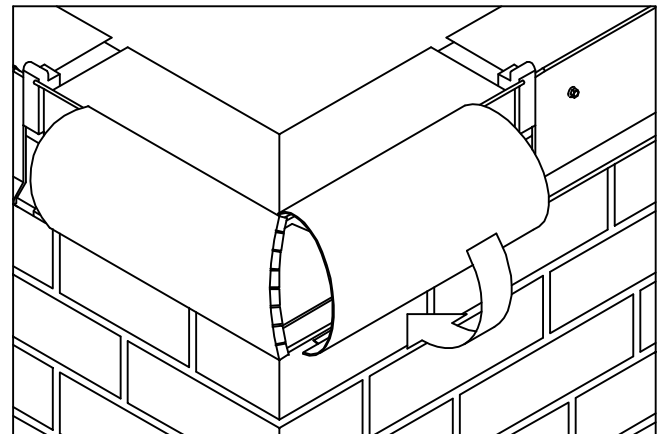

9. Miter Cover (Left Half)

Next, install left half of miter cover. Place miter cover half over anchor bar with the face angled up to allow enough clearance past the support clip. Rotate cover into place. Engage cover to anchor bar by applying slight downward and inward pressure with palm of hand.

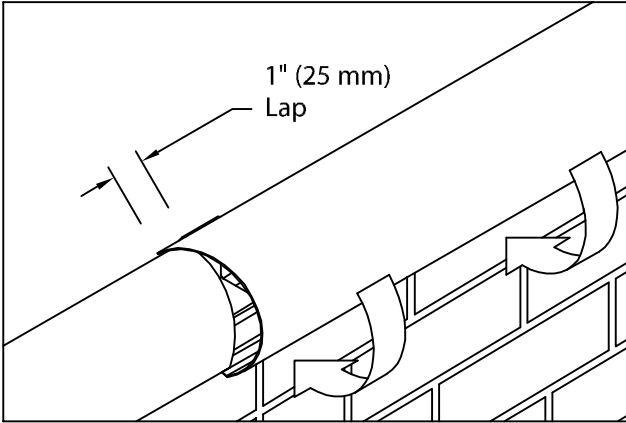

10. Fascia Covers

Place 4'-0" (1.22 m) fascia cover over anchor bar with the face angled up to allow enough clearance past the support clip. Rotate cover into place. Engage cover to anchor bar by applying slight downward and inward pressure with palm of hand. Continue installation by overlapping preceding cover approximately 1" (25 mm) at notches provided. Fascia covers shall be installed from right to left as seen from rooftop. Where field cutting is necessary, use a fine tooth hacksaw.

IMPORTANT! Be sure to remove protective plastic film prior to installing each fascia section.

