

FLEXCAP FLC QUICKLOCK RADIUS COPING

EXSITING SLOPE WITH NAILER VERSION

IMPORTANT!!! MUST INDICATE PROPER RADIUS CONDITION BY CIRCLING APPROPRIATE OUTSIDE FACE

PROVIDING A RADIUS
THE RADIUS MAY BE PROVIDED
IN ONE OF TWO METHODS:

1.) THE ACTUAL KNOWN RADIUS IS

' FEET " INCHES

OR

2.) FIELD CONDITION MEASUREMENTS

NOTE: REFER TO ATTACHED WORKSHEET
FOR FURTHER INFORMATION

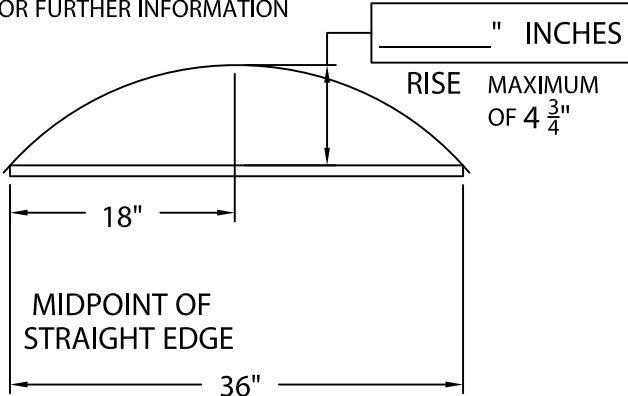

LENGTH OF
STRAIGHT EDGE

NOTE: CHECK MEASUREMENTS ALONG ENTIRE RADIUS.

DETAIL A

MINIMUM
OF 3'-0"

RISE

SUBSTRATE CONDITION

OUTSIDE
FACE

OUTSIDE
FACE

RADIUS
(PROVIDED BY APPROVER
PER DETAIL A)

TOP
VIEW

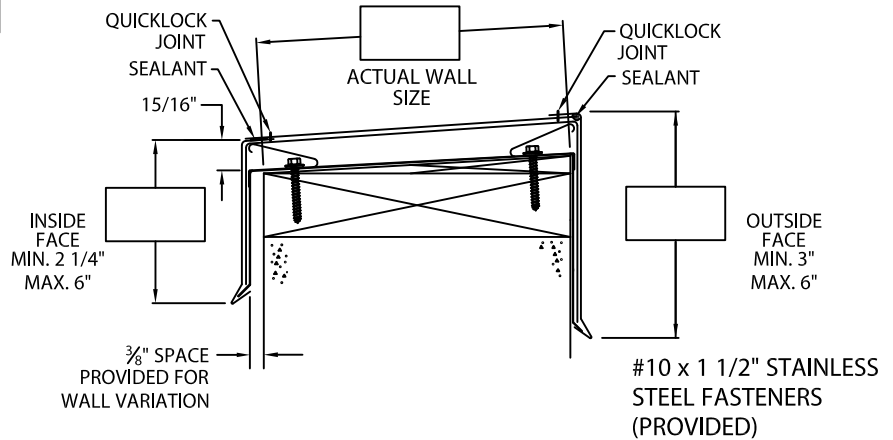

NOTES: -- Concealed splice plates are provided with factory applied dual non-curing sealant strips.

-- Fabrication of radius is furnished utilizing a non-penetrating quicklock joint, then factory sealed watertight.

Fabrication will proceed only after receipt of signed print approval.

Print Approval:

Architect and/or contractor shall verify all dimensions, sizes and quantities. All products to be installed in strict accordance with Flex's printed instructions.

Approved by: _____

Date: _____

MATERIAL:

- ___ 24 Ga. Steel
- ___ .040" Aluminum
- ___ .050" Aluminum
- ___ .063" Aluminum
- ___ Other _____

Color: _____

Finish: _____

QUANTITIES:

_____ Lineal Feet 4'-0" Lengths

PROJECT:

ARCHITECT:

ROOFING CONTRACTOR:

REPRESENTATIVE/DISTRIBUTOR:

Customer Service:

Phone: 800-969-0108

Fax: 610-916-9501



DATE: 12/28/16

DRN BY: JAB

CKD BY: SAK

SHT.# ___ OF ___

DWG# 28011-13528

C