



FIBERTITE GOLD COPING

TAPERED VERSION - 2'-0" O.C.

INSTALLATION INSTRUCTIONS

IMPORTANT: PRIOR TO INSTALLATION, READ INSTRUCTIONS CAREFULLY.

NOTE: POSITION ROOF MEMBRANE ON TOP OF THE WALL COVERING THE TREATED WOOD NAILER(S) OR SUBSTRATE COMPLETELY. ALLOW 1/2" MINIMUM EXCESS MEMBRANE BEYOND NAILER WHERE APPLICABLE. NRCA REQUIREMENT.

CAUTION: INSTALL MITERS FIRST!

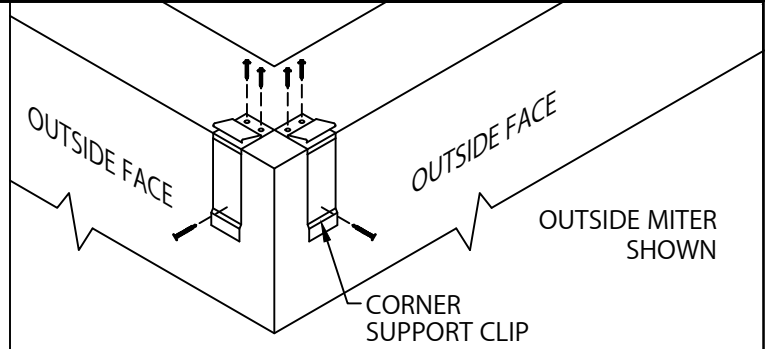

STEP 1 - CORNER SUPPORT CLIPS
LOCATE AND FASTEN GALVANIZED CORNER SUPPORT CLIPS TO THE WALL.

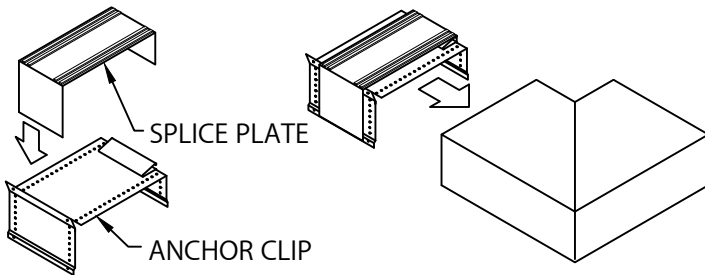

STEP 2 - MITER SPLICE PLATES & ANCHOR CLIPS

REMOVE RELEASE PAPER FROM SPLICE PLATE SEALANT STRIPS. POSITION THE SPLICE PLATE IN THE CENTER OF THE ANCHOR CLIP. INSTALL THE SPLICE PLATE AND ANCHOR CLIP ASSEMBLY INTO EACH END OF THE CORNER AS SHOWN.

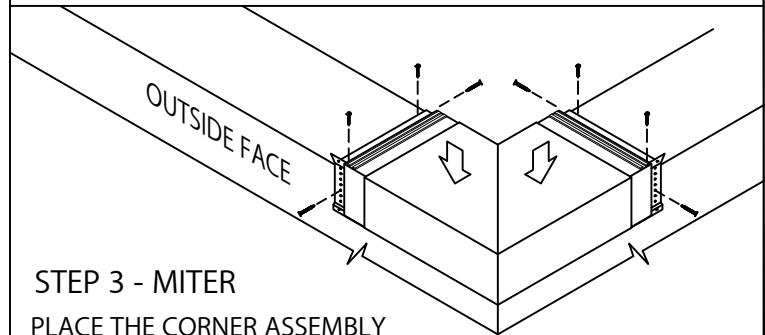

STEP 3 - MITER
PLACE THE CORNER ASSEMBLY INTO POSITION AND SECURE AT THE EXPOSED EDGE OF THE ANCHOR CLIPS AS PER DETAIL A.

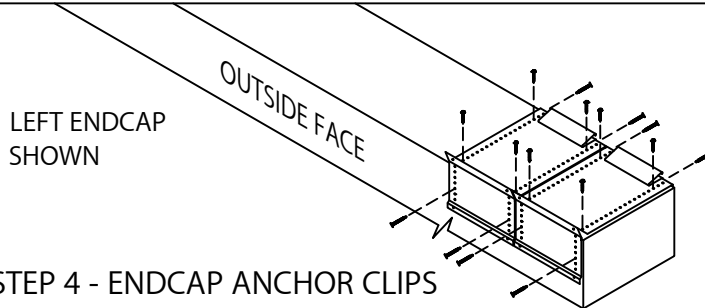

STEP 4 - ENDCAP ANCHOR CLIPS
LOCATE AND FASTEN GALVANIZED ANCHOR CLIPS TO WALL WITH PROVIDED FASTENERS FOR SUBSTRATE (SEE DETAIL A).

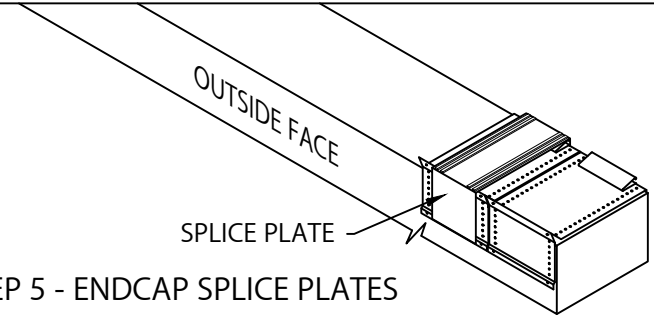

STEP 5 - ENDCAP SPLICE PLATES
REMOVE RELEASE PAPER FROM SPLICE PLATE SEALANT STRIPS. PLACE SPLICE PLATE ONTO ANCHOR CLIP AS SHOWN.

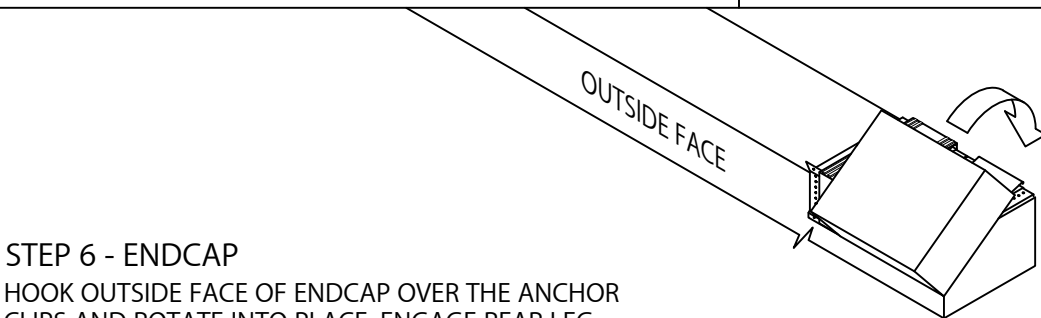

STEP 6 - ENDCAP
HOOK OUTSIDE FACE OF ENDCAP OVER THE ANCHOR CLIPS AND ROTATE INTO PLACE. ENGAGE REAR LEG ONTO ANCHOR CLIPS BY PRESSING DOWNWARD UNTIL SNAP LOCK OCCURS.



Phone: 800-927-8578
ext. 1235
fax: 330-263-6950

DATE: 06/17/22
DRN BY: MLM
CKD BY: MM

SHT.# 1 OF 3
DWG# 23111-38718

A



FIBERTITE GOLD COPING

TAPERED VERSION - 2'-0" O.C.

INSTALLATION INSTRUCTIONS

INSTALLATION NOTES:

1) Installing contractor shall check as-built conditions, including nailer attachment, and verify the manufacturer's coping details for accuracy to fit the wall assembly prior to fabrication.

2) Fasteners must be corrosion resistant and rated for a minimum 250# pullout force for the substrate that is being used.

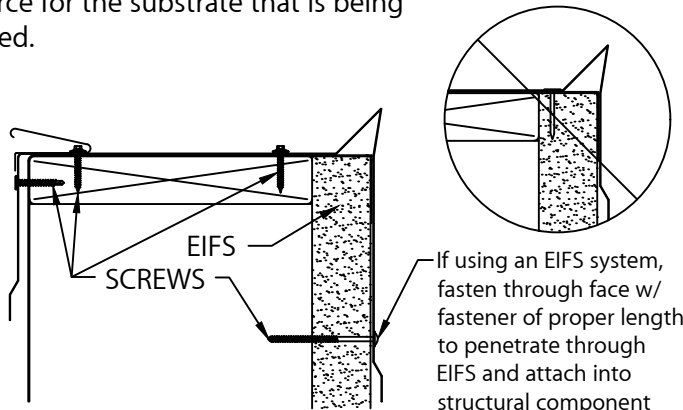

If using an EIFS system, fasten through face w/ fastener of proper length to penetrate through EIFS and attach into structural component

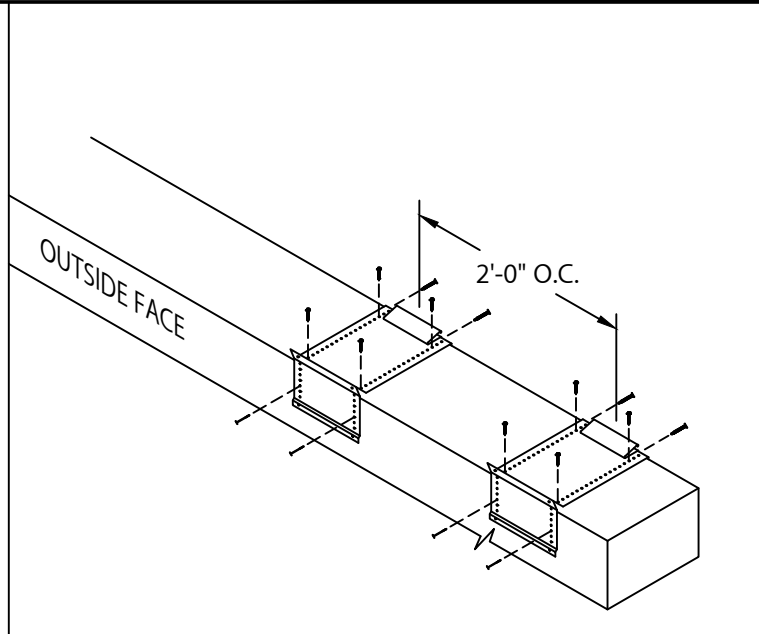

STEP 7 - ANCHOR CLIPS

LOCATE OVER MEMBRANE AND FASTEN GALVANIZED ANCHOR CLIPS TO WALL AT 2'-0" ON CENTER WITH PROVIDED FASTENERS AS SHOWN IN DETAIL A.

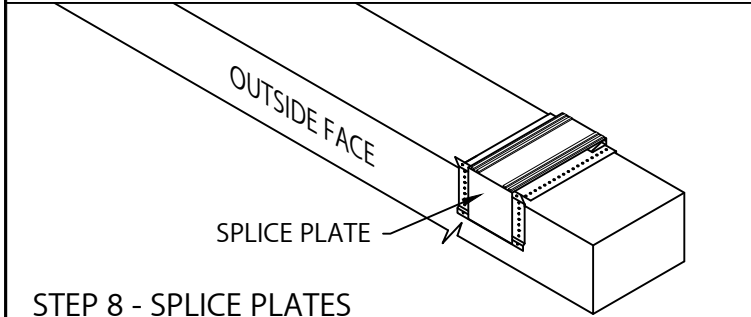

STEP 8 - SPLICE PLATES

PLACE SPLICE PLATE ONTO ANCHOR CLIPS AT SPLICE JOINTS

NOTE: REMOVE RELEASE PAPER FROM SEALANT STRIPS.

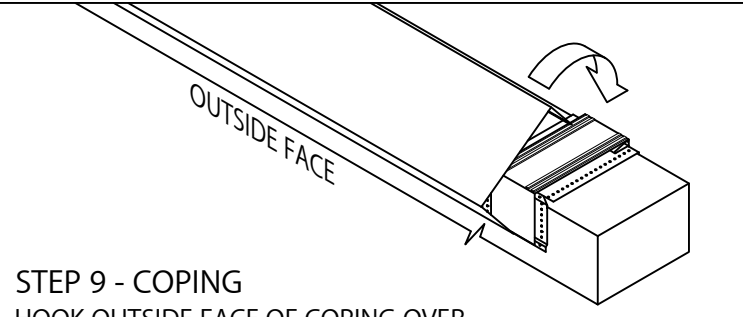

STEP 9 - COPING

HOOK OUTSIDE FACE OF COPING OVER THE ANCHOR CLIPS AND ROTATE INTO PLACE. ENGAGE REAR LEG ONTO ANCHOR CLIPS BY PRESSING DOWNWARD UNTIL SNAP LOCK OCCURS.

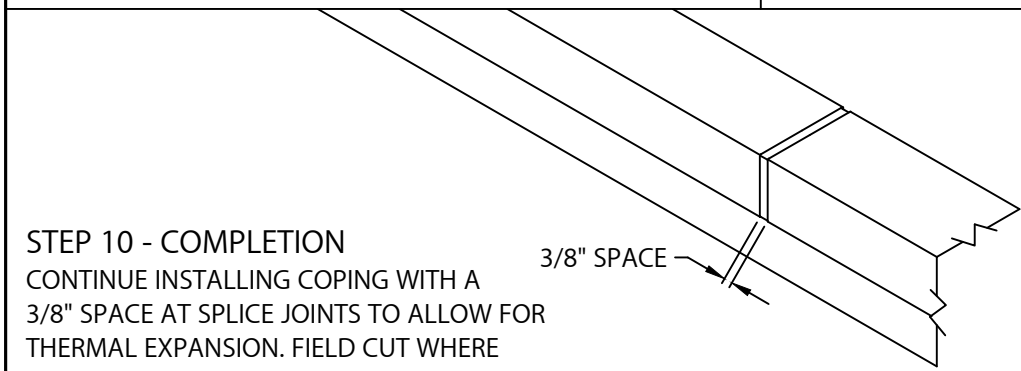

STEP 10 - COMPLETION

CONTINUE INSTALLING COPING WITH A 3/8" SPACE AT SPLICE JOINTS TO ALLOW FOR THERMAL EXPANSION. FIELD CUT WHERE NECESSARY USING FINE TOOTH HACKSAW OR SNIPS.

NOTE: REMOVE PROTECTIVE FILM IMMEDIATELY.



Phone: 800-927-8578
ext. 1235
fax: 330-263-6950

DATE: 06/17/22
DRN BY: MLM
CKD BY: MM

SHT.# 2 OF 3
DWG# 23111-38718

A



FIBERTITE GOLD COPING

TAPERED VERSION - 2'-0" O.C.

INSTALLATION INSTRUCTIONS

TYPICAL COPING INSTALLATION DETAIL A

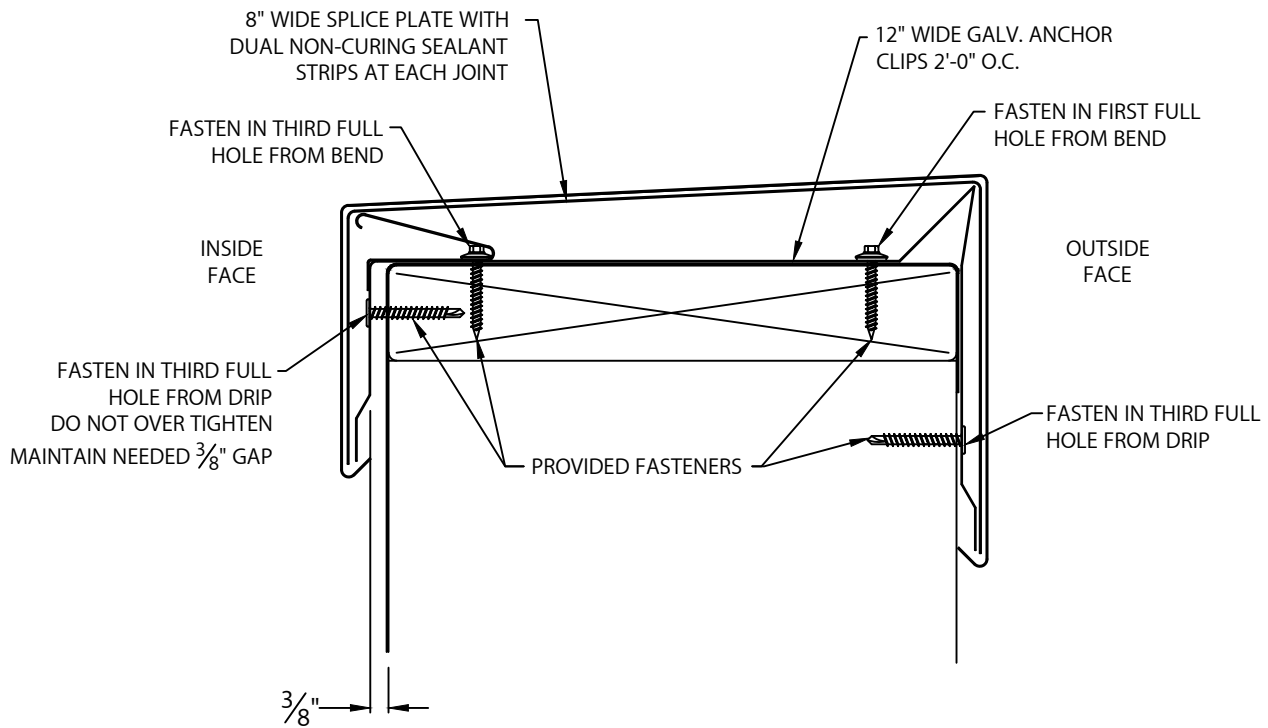

Phone: 800-927-8578
ext. 1235
fax: 330-263-6950

DATE: 06/17/22
DRN BY: MLM
CKD BY: MM

SHT.# 3 OF 3
DWG# 23111-38718

A