

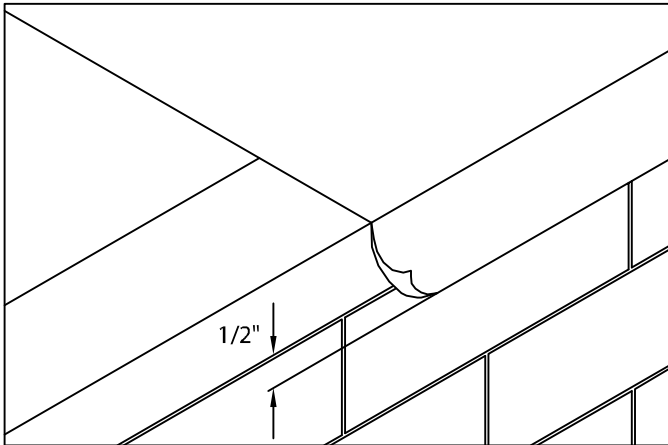

FIBERTITE 200 FASCIA

CRIMP-ON VERSION

INSTALLATION INSTRUCTIONS



1. POSITION MEMBRANE OVER THE ROOF EDGE AND DOWN OUTSIDE FACE OF WALL, COVERING TREATED WOOD NAILER(S) COMPLETELY. ALLOW $\frac{1}{2}$ " EXCESS MEMBRANE.

IMPORTANT! OUTSIDE EDGE OF TREATED WOOD NAILER(S) (MINIMUM 2 x 4) SHALL BE ALIGNED FLUSH WITH OR EXTEND SLIGHTLY PAST OUTERMOST EDGE OF WALL.

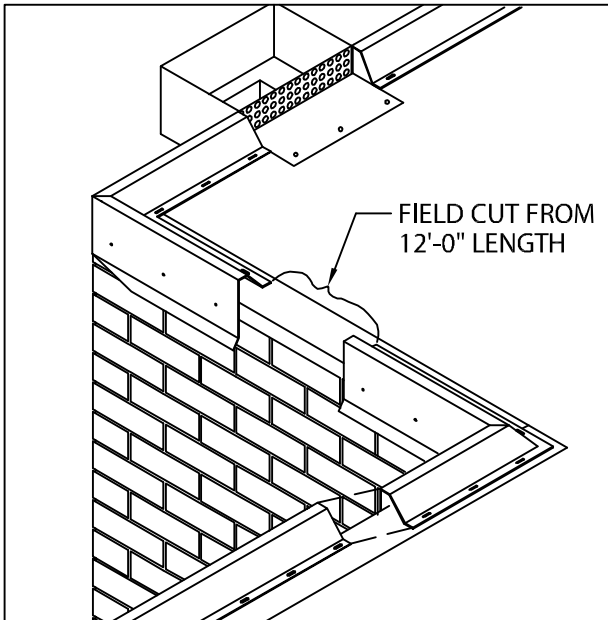

2. LOCATE AND INSTALL MITERS, NAILING THROUGH PRE-SLOTTED FASTENING HOLES ON TOP FLANGE ONLY. DETERMINE AND IDENTIFY LOCATION OF SCUPPERS. LEAVE GAP OF 14 $\frac{1}{2}$ " INCHES FOR SCUPPER LOCATIONS. NEXT LOCATE AND INSTALL SCUPPERS. SEE PAGES 4 AND 5 FOR DETAILED INSTRUCTIONS ON INSTALLING SCUPPERS. THEN INSTALL THE 12'-0" SECTIONS OF WATERDAM FROM RIGHT TO LEFT (AS SEEN FROM ROOF TOP) BY NAILING THROUGH SLOTTED HOLES PROVIDED PER JOB REQUIREMENTS. FIELD CUT SECTIONS AS NECESSARY. LAP WATERDAM JOINTS 1".

NOTE: DO NOT ATTACH FACE OF WATERDAM AT THIS TIME.

PROVIDED WATERDAM FASTENER: 1 $\frac{1}{4}$ " RING SHANK GALVANIZED ROOFING NAILS.

CAUTION : INSTALLERS SHALL WEAR PROTECTIVE EYEWEAR TO PREVENT SERIOUS INJURY.



FIBERTITE 200 FASCIA

CRIMP-ON VERSION

INSTALLATION INSTRUCTIONS

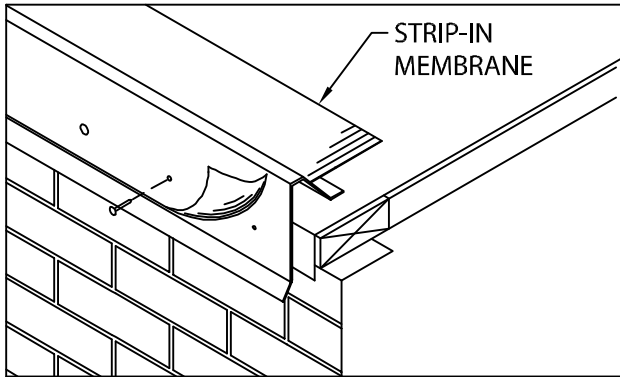

3. POSITION STRIP-IN MEMBRANE OVER AND DOWN WATERDAM FACE APPROXIMATELY 1" BELOW RAISED FASTENING HOLES (PROVIDED). TAKE CARE TO AVOID BRIDGING OF MEMBRANE. LOCATE AND NAIL MEMBRANE AT 12" O.C. THROUGH ALL RAISED HOLES ON OUTSIDE FACE USING 1 1/4" RING SHANK NAILS PROVIDED.

NOTE: FOLLOW GENERAL RECOMMENDATIONS OF THE STRIP-IN MEMBRANE MANUFACTURERS APPLICATION OF MATERIALS OVER THE ROOF EDGE.

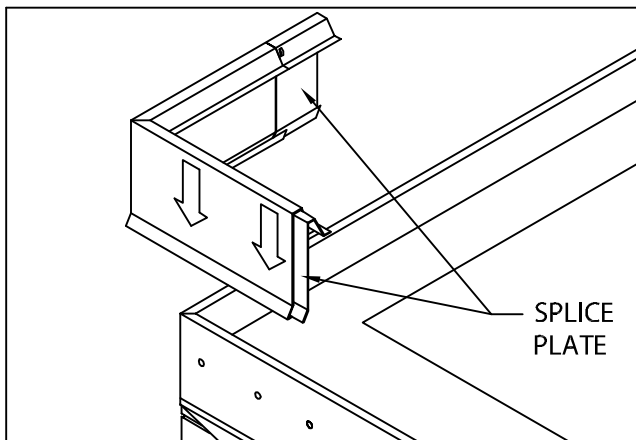

4. INSTALL MITER COVERS FIRST. INSERT ONE SPLICE PLATE UNDER EACH END OF MITER COVER. ALLOW 3/8" SPACE BETWEEN ENDS OF ADJOINING FASCIA PANELS. INSTALL MITER COVERS BY PUSHING DOWNWARD UNTIL COVER IS ENGAGED ALONG ENTIRE MITER. CRIMP ENTIRE DRIP EDGE OF EACH MITER COVER AS SHOWN IN STEP #6.

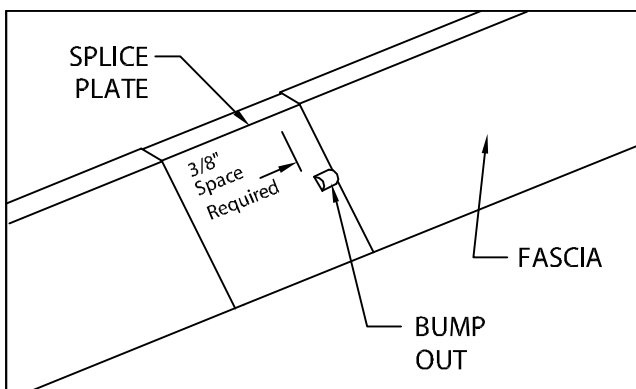

5. INSTALL 12'-0" FASCIA COVER SECTIONS. INSERT ONE SPLICE PLATE UNDER EACH OF THE FASCIA COVERS. INSTALL COVER BY PUSHING DOWNWARD UNTIL FASCIA COVER IS ENGAGED TO WATER DAM ALONG ENTIRE LENGTH. CONTINUE TO INSTALL FASCIA COVERS, FIELD CUTTING WHERE NECESSARY USING FINE TOOTH HACKSAW.



FIBERTITE 200 FASCIA

CRIMP-ON VERSION

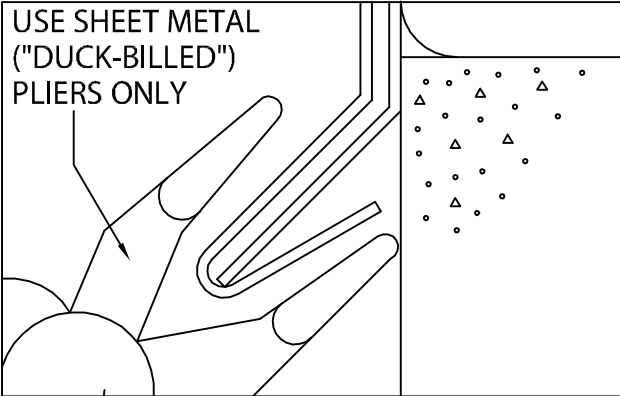

6. IMPORTANT!

FIELD CRIMP THE DRIP EDGE AT ALL JOINTS AND AT 18" O.C. USING A PAIR OF 3" WIDE SHEET METAL (AS SHOWN ON LEFT).

CAUTION : REMOVE PROTECTIVE FILM IMMEDIATELY AFTER INSTALLATION, WHERE APPLICABLE.

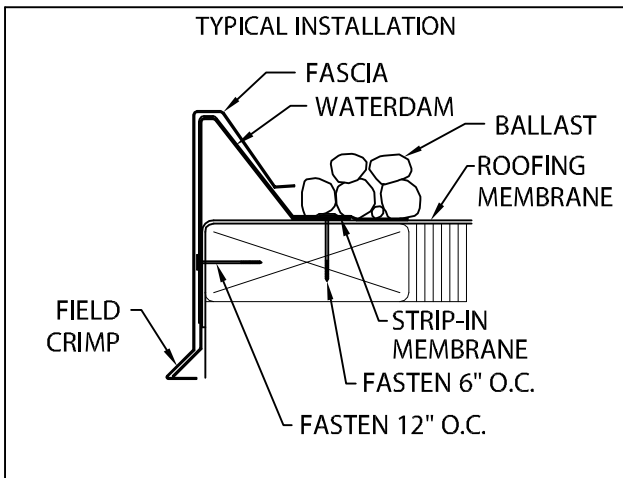

7. COMPLETE INSTALLATION BY PLACING BALLAST (IF REQUIRED), FOLLOWING ROOF MEMBRANE MANUFACTURERS' RECOMMENDATIONS.