



CARLISLE INDUSTRIAL GUTTER SYSTEM

IG-1, IG-2 OR IG-B VERSION
INSTALLATION INSTRUCTIONS

Note: Either Term. Bar, Gravel stop, or Drip edge must be used to receive <FM> approval.

TYPICAL MEMBRANE OPTIONS

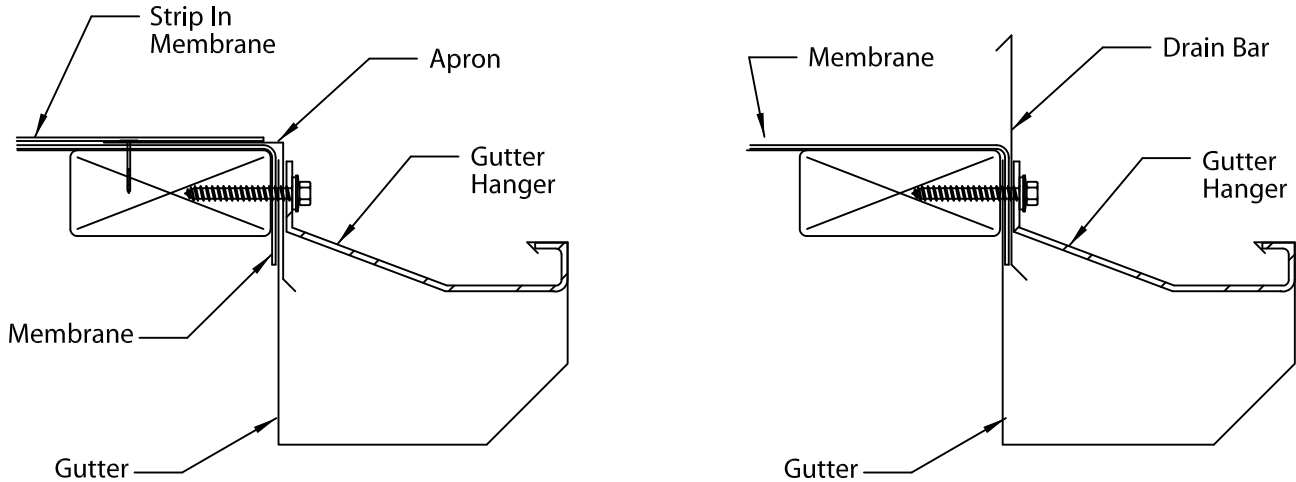

STEP 1. MEMBRANE INSTALLATION

Review carefully and follow Carlisle's recommendations, and architect's details for installing roof membranes in conjunction with this gutter system.

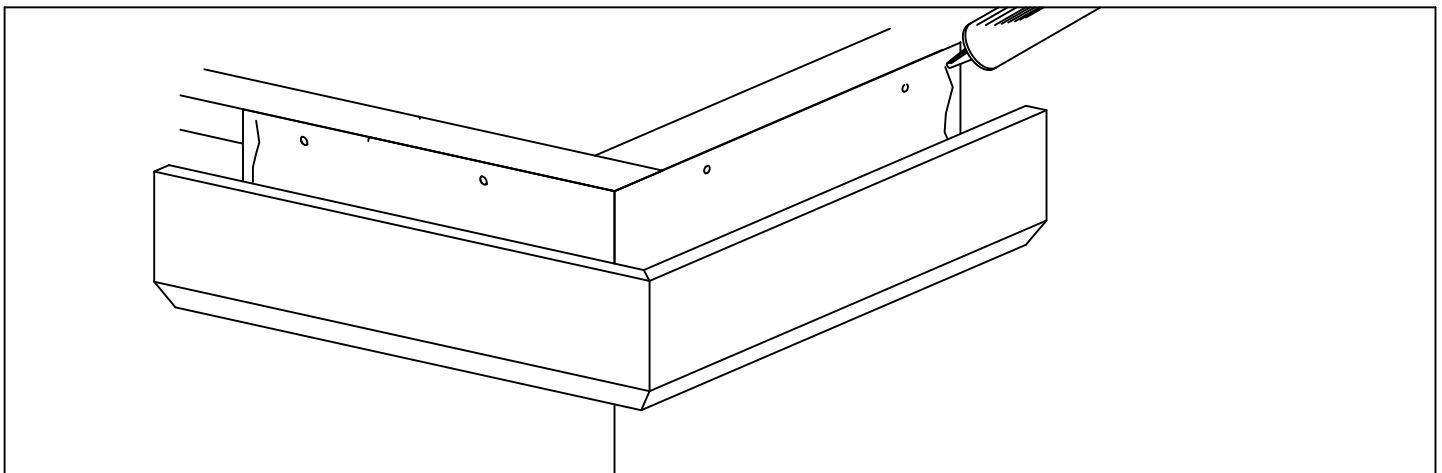

STEP 2. MITER INSTALLATION

Install miter units at locations shown on plans. Fasten to nailer through pre-slotted holes @ 12" O.C. using provided 1 1/4" galvanized roofing nails. Apply a heavy bead of non-curing sealant to the inside of each miter end as shown.



Customer Service
866-458-3537
(Metal-Era)

DATE: 03/22/17
DRN BY: JAB
CKD BY: SAK

SHT.# 1 OF 4
DWG# 15112-1713



CARLISLE INDUSTRIAL GUTTER SYSTEM

IG-1, IG-2 OR IG-B VERSION

INSTALLATION INSTRUCTIONS

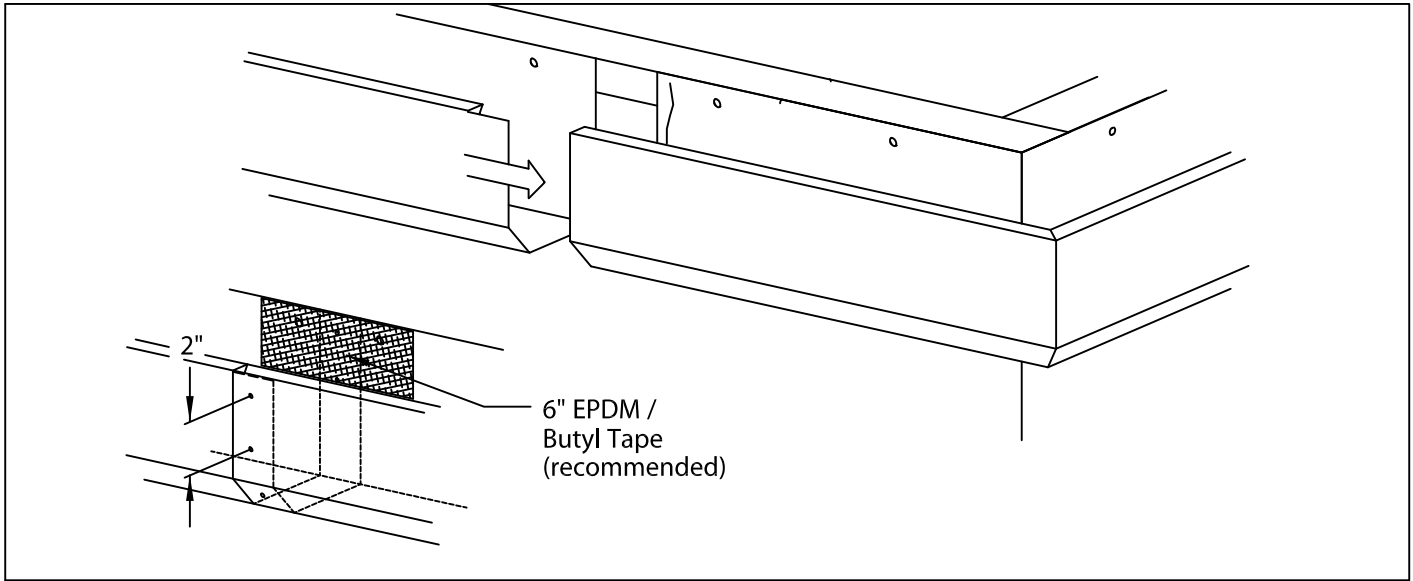

STEP 3. GUTTER INSTALLATION

Install gutter sections from right to left as seen from roof. Insert notched end of gutter section into open end with applied sealant for a distance of 2". Rivet assembled sections at lap joint 2" o.c. using provided 1/8" stainless steel pop rivets. Field notch miter ends and/or expansion joints as required. Nail gutter sections to nailer at 12" O.C. using provided 1 1/4" galvanized roofing nails. Carlisle recommends the application of a 6" wide EPDM / Butyl pressure sensitive tape centered over the lap joint.

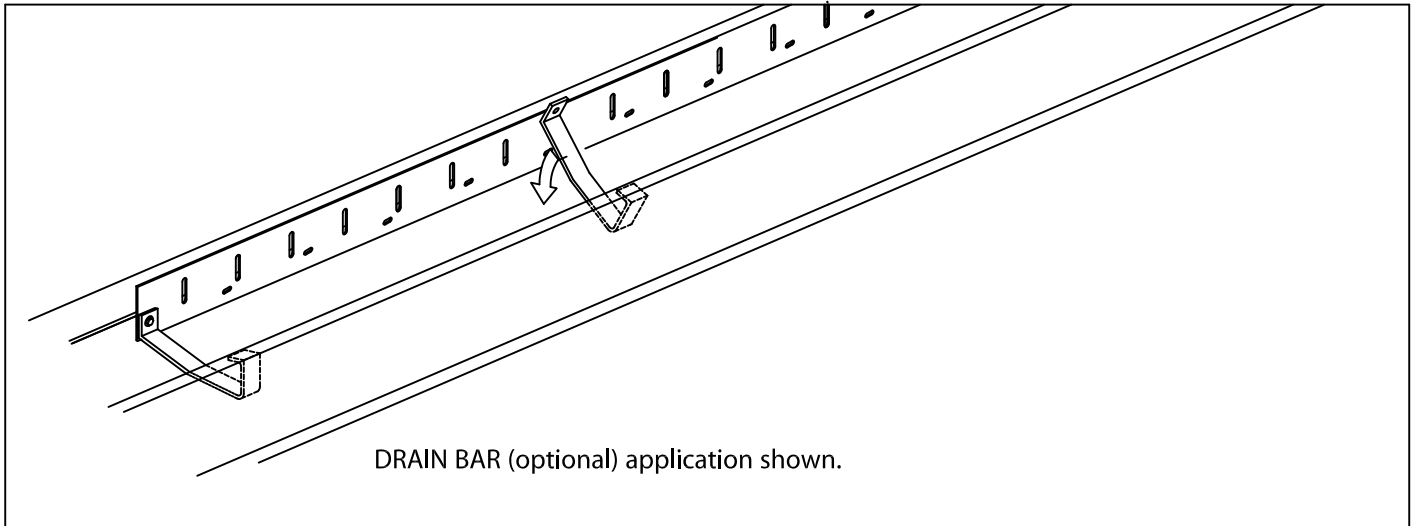

STEP 4. HANGER INSTALLATION

Hook hanger under leading edge of gutter and rotate into place. Fasten hanger @ 30" O.C. using a provided #10 x 2" stainless steel fasteners through back side of gutter into wood nailer.



Customer Service
866-458-3537
(Metal-Era)

DATE: 03/22/17
DRN BY: JAB
CKD BY: SAK

SHT.# 2 OF 4
DWG# 15112-1713 |



CARLISLE INDUSTRIAL GUTTER SYSTEM

IG-1, IG-2 OR IG-B VERSION

INSTALLATION INSTRUCTIONS

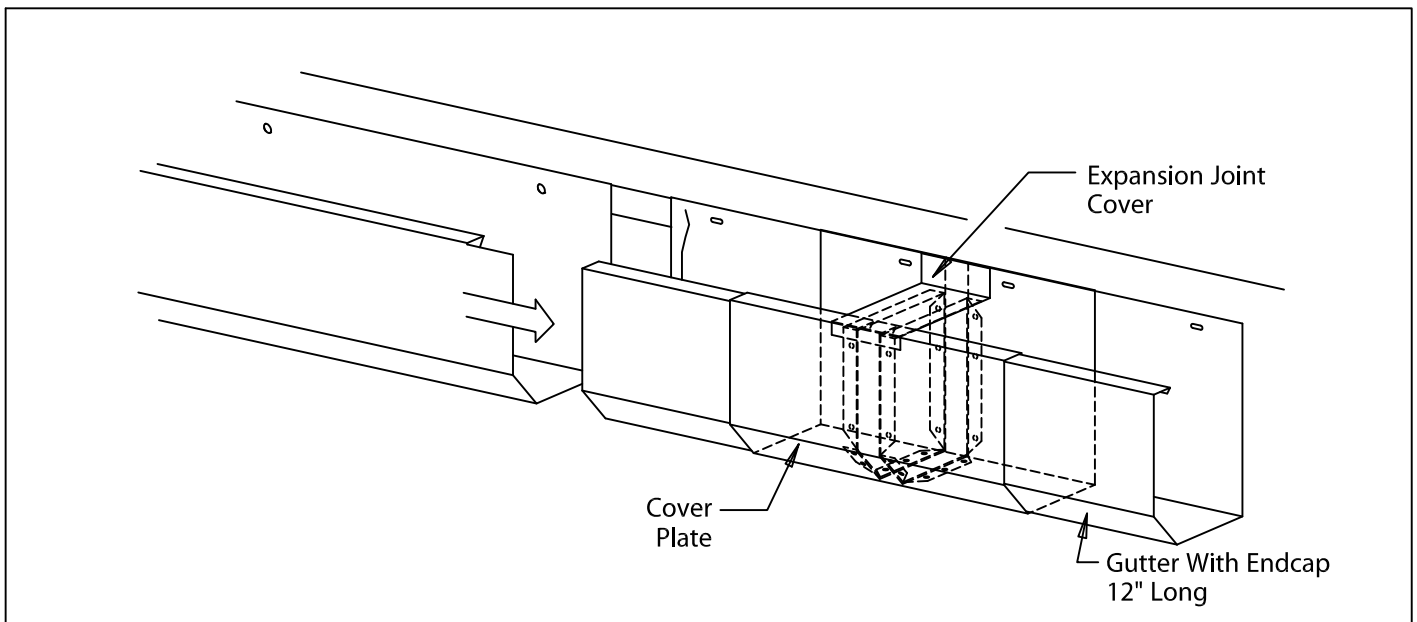

STEP 5. EXPANSION JOINT INSTALLATION (WHERE NECESSARY)

Install expansion joints in locations as specified on roof plans or at a maximum of 48'-0". Nail into place as per Step #3.

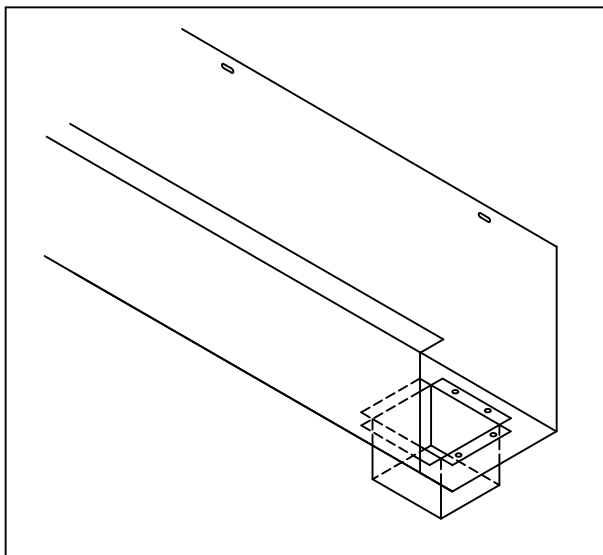

STEP 6. OUTLET INSTALLATION

Determine outlet locations and field cut hole in a neat workmanlike manner. Insert aluminum outlet, fasten with provided 1/8" stainless steel pop rivets, 2 rivets in each flange and seal, with non-curing sealant.

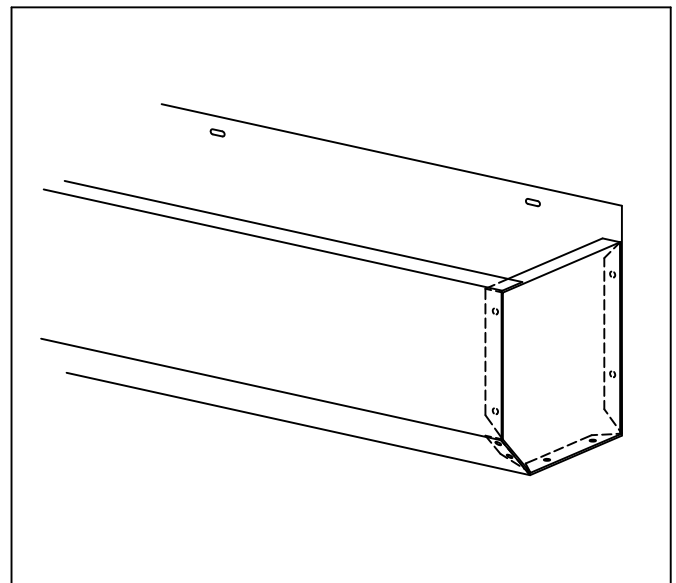

STEP 7. END CAP INSTALLATION

Install end caps at all terminations. Field rivet with provided 1/8" stainless steel pop rivets at 2" O.C. and seal, with non-curing sealant.



Customer Service
866-458-3537
(Metal-Era)

DATE: 03/22/17
DRN BY: JAB
CKD BY: SAK

SHT.# 3 OF 4
DWG# 15112-1713 |

CARLISLE INDUSTRIAL GUTTER SYSTEM

STYLE 2 GUTTER EXPANSION JOINT

INSTALLATION INSTRUCTIONS

1 CUT A 12'-0" SECTION OF THE GUTTER INTO (2) 6'-0" PIECES.
(THE EXPANSION JOINT IS DESIGNED TO FIT BETWEEN THE (2) 6'-0" SECTIONS).

2 SLIDE GUTTER SECTION OVER THE EXPANSION PLATE UNTIL LEAD EDGE OF GUTTER MEETS NEOPRENE INSERT
APPLY A HEAVY BEAD OF NON-CURING SEALANT TO THE INSIDE OF THE GUTTER SECTION.

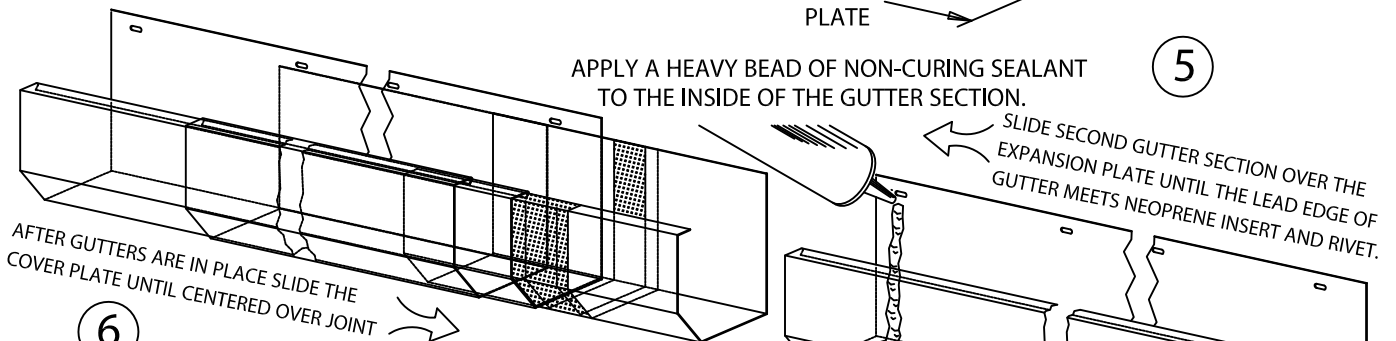
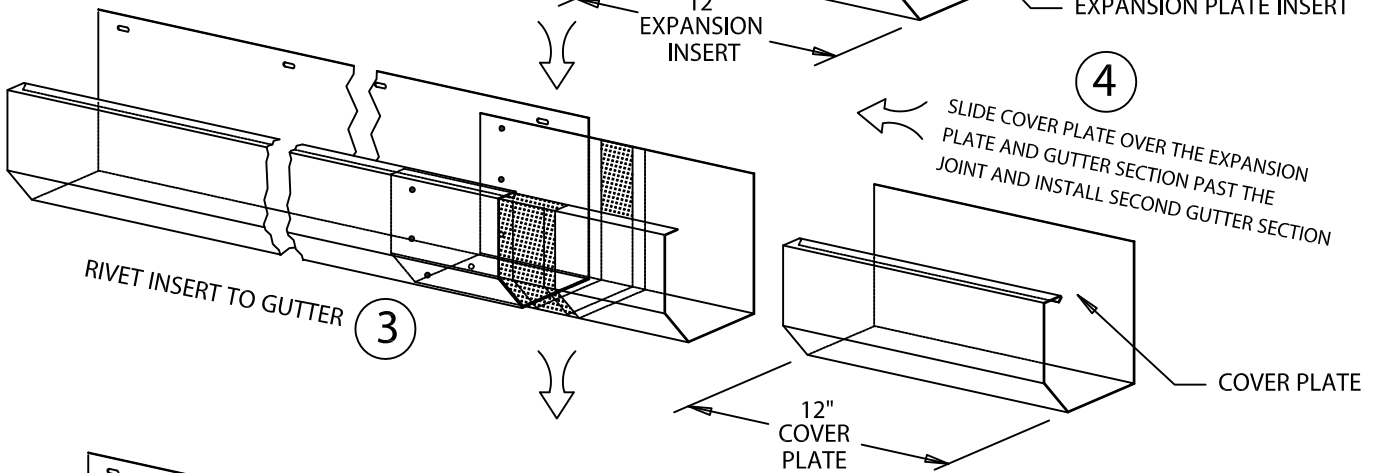
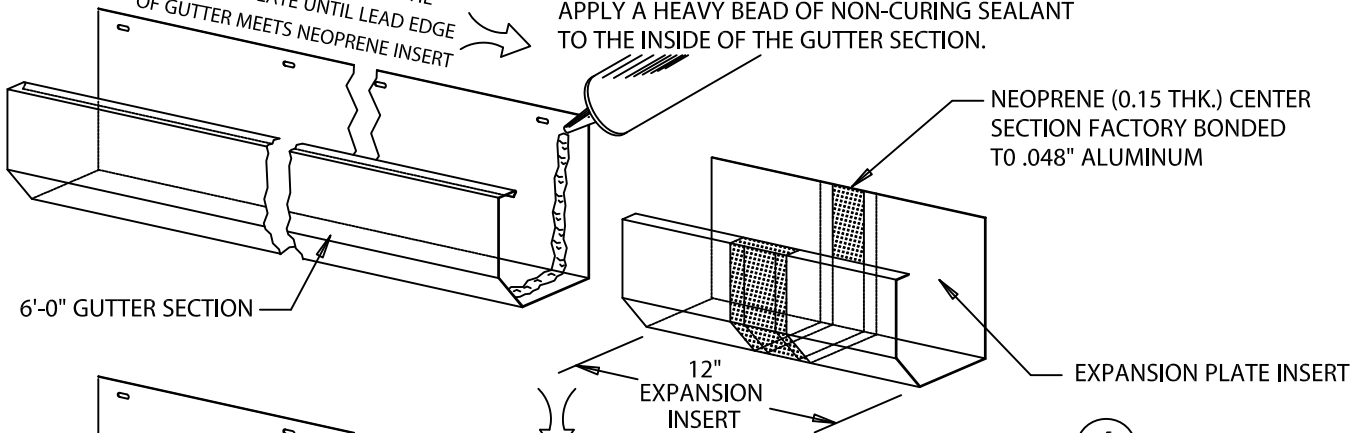

6

AFTER GUTTERS ARE IN PLACE SLIDE THE COVER PLATE UNTIL CENTERED OVER JOINT

Diagram 6 shows the cover plate being slid until it is centered over the joint.

7 COMPLETION

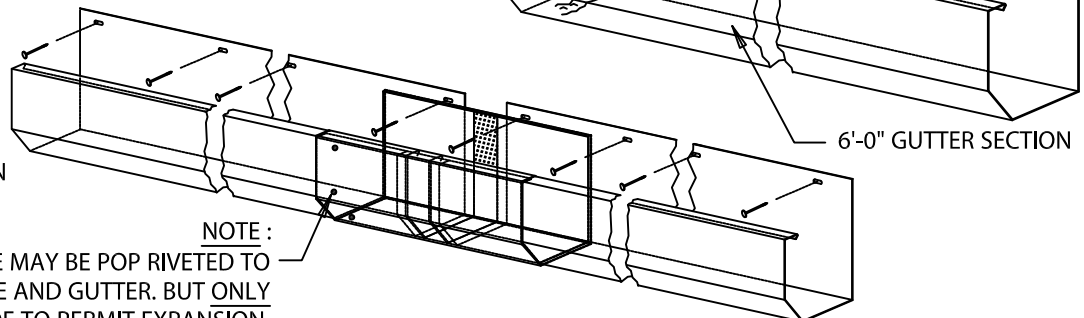

NOTE :
THE COVER PLATE MAY BE POP RIVETED TO THE EXPANSION PLATE AND GUTTER, BUT ONLY ON ONE SIDE TO PERMIT EXPANSION.



Customer Service
866-458-3537
(Metal-Era)

DATE: 03/22/17
DRN BY: JAB
CKD BY: SAK

SHT.# 4 OF 4
DWG# 15112-1713