

MOUNTING ANGLE

FOR USE WITH SEAL-TITE XL GUTTER

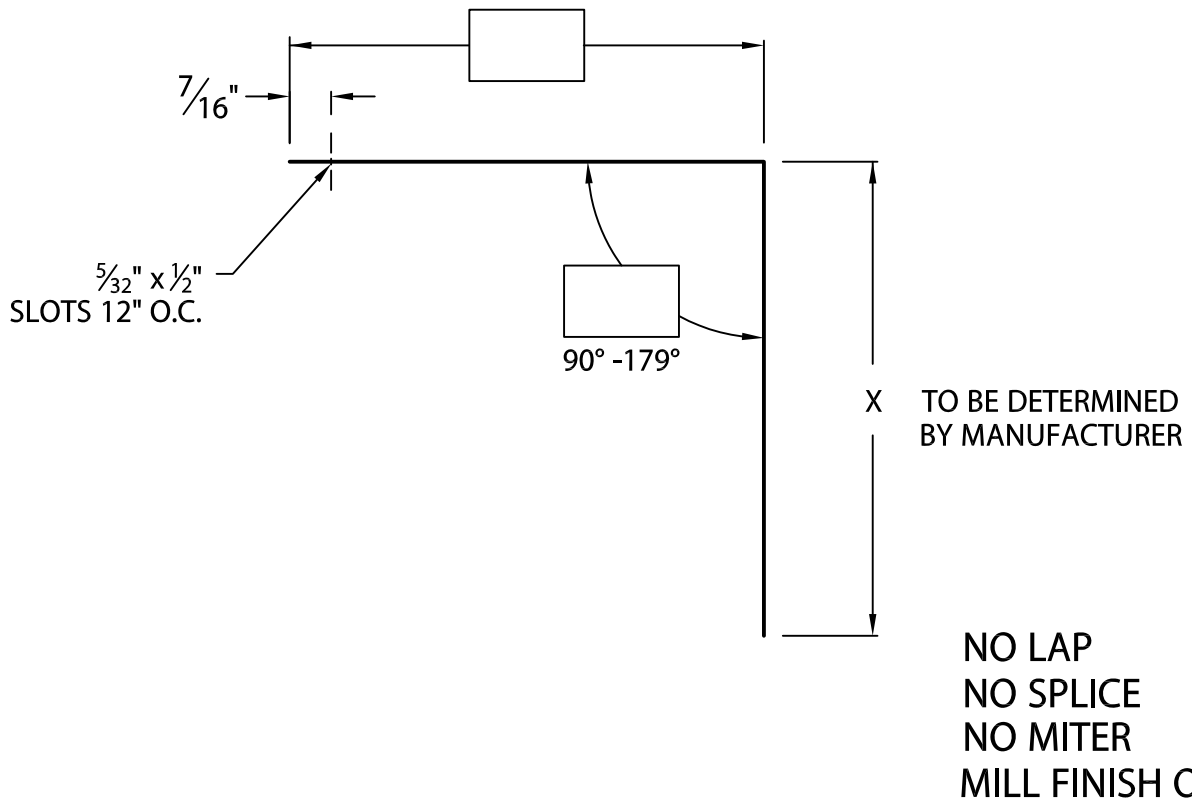

Fabrication will proceed only after receipt of signed print approval.

Print Approval:

Architect and/or contractor shall verify all dimensions, sizes and quantities. All products to be installed in strict accordance with Metal-Era's printed instructions.

Approved by: _____

Date: _____

FRONT AND BOTTOM HEIGHT	MATERIAL
<input type="checkbox"/> 8" <input type="checkbox"/> 9"	.063" ALUMINUM
<input type="checkbox"/> 10" <input type="checkbox"/> 11"	.080" ALUMINUM
<input type="checkbox"/> 12" <input type="checkbox"/> 13"	.100" ALUMINUM
<input type="checkbox"/> 14"	.125" ALUMINUM

QUANTITIES:

_____ LINEAL FEET 12'-0" LENGTHS

PROJECT:	Corporate Offices, Manufacturing 1600 Airport Road; Waukesha, WI 53188 Phone: 800-558-2162 Fax: 800-373-9156 www.metalera.com
ARCHITECT:	
ROOFING CONTRACTOR:	
REPRESENTATIVE/DISTRIBUTOR:	



DATE: 07/19/23	SHT.# ____ OF ____
DRN BY: MLM	DWG# 11018-41153
CKD BY: MM	

A