

SECUREDGE 200 RADIUS COPING

OVER 6" TO 12" FACE HEIGHT, MASONRY ATTCHED TAPERED VERSION - 4'-0" O.C.

INSTALLATION INSTRUCTIONS

NOTE: Position roof membrane on top of the wall covering the treated wood nailer(s) or substrate completely. Allow 1/2" (13 mm) minimum excess membrane beyond nailer where applicable. NRCA Requirement.

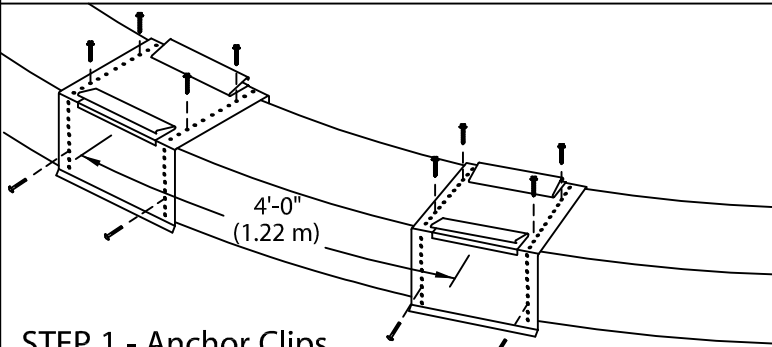

STEP 1 - Anchor Clips

Locate and fasten 8" (203 mm) wide anchor clips at 4'-0" (1.22 m) O.C. with provided fasteners for substrate (see detail A).

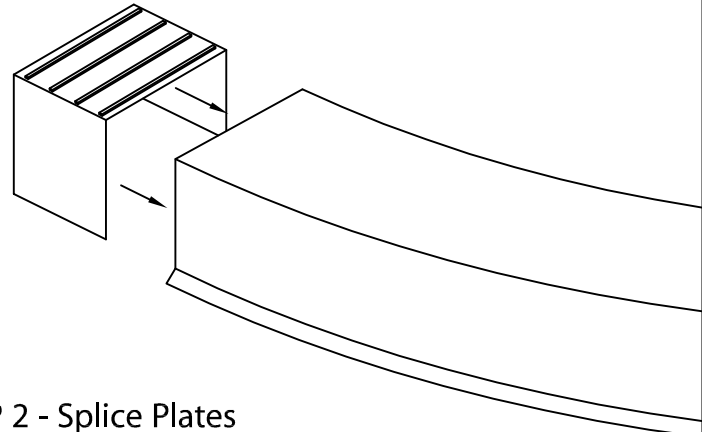

STEP 2 - Splice Plates

Remove release paper from left two sealant strips. Insert splice plate into the right end of radius section.

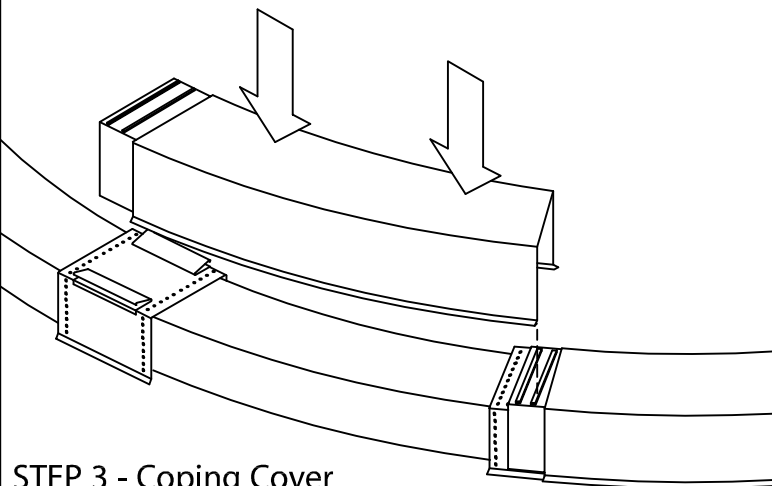

STEP 3 - Coping Cover

Remove release paper from right two factory applied sealant strips on the splice plate in the coping section. Install 4'-0" (1.22 m) radius coping sections from left to right. Place coping into position and press downward until snap-lock occurs.

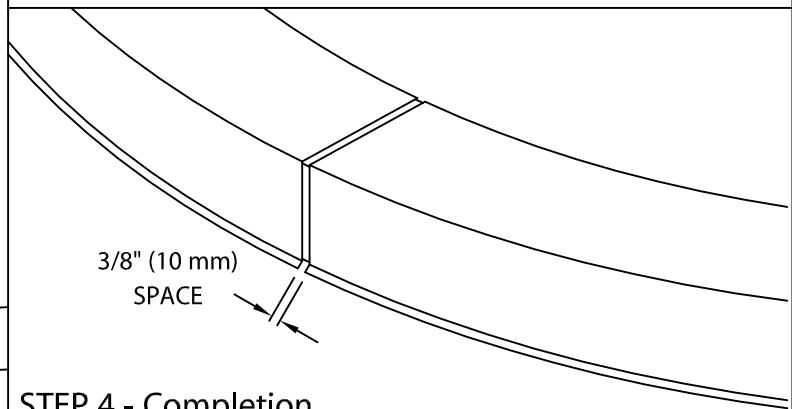

STEP 4 - Completion

Continue installing coping with a 3/8" (10 mm) space at splice joints to allow for thermal expansion. Field cut where necessary using a fine tooth hacksaw or snips.

NOTE: REMOVE PROTECTIVE FILM IMMEDIATELY.

ANCHOR CLIP FASTENING-DETAIL A

LOCATE FASTENERS IN THIRD FULL HOLE FROM BEND

OUTSIDE FACE

INSIDE FACE

LOCATE ADDITIONAL FASTENER IN ONE OF THE FIRST FIVE FULL HOLES FROM THE DRIP

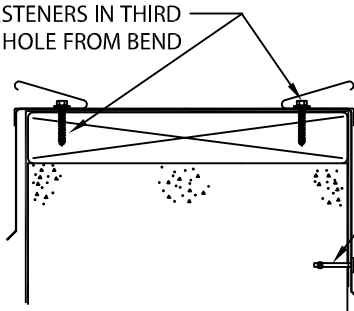

TYPICAL COPING INSTALLATION

6" (153 mm) WIDE SPLICE PLATES WITH SEALANT STRIPS AT EACH JOINT

8" (203 mm) WIDE GALVANIZED ANCHOR CLIPS 4'-0" (1.22 m) O.C.

INSIDE FACE

OUTSIDE FACE

3/8" (10 mm)

#9 x 1 1/2" (38 mm) STAINLESS STEEL FASTENERS (PROVIDED)

3/16" (5 mm) x 7/8" (22 mm) ZAMAC FASTENERS (PROVIDED)

