



ELEVATE EXTENDED MB RAIL FASCIA

BUILT-UP OR MODIFIED VERSION

NOTES

- Fascia cover provided with splice plates
- Rail miters are not provided (cover only)
- For non-90 miters, see separate print approval
- Product should be installed per provided installation instructions
- ANSI/SPRI/FM 4435/ES-1 Test Pressure up to 146 psf

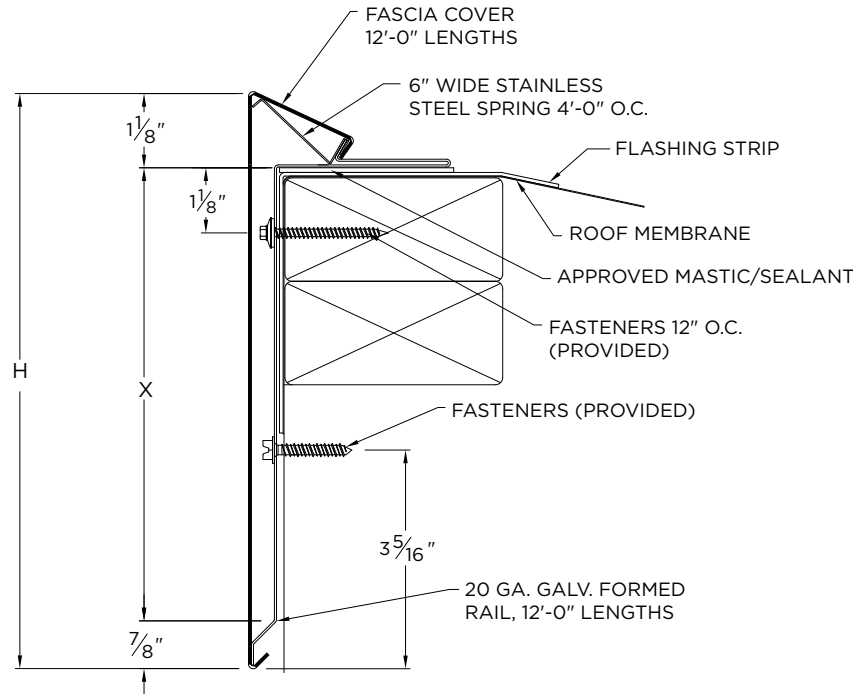

APPROVALS



ANSI/SPRI/FM 4435/ES-1
Test Pressures listed in notes

PROJECT INFO

Project Name: _____

Architect: _____

Roofing Contractor: _____

Project Type:

By selecting this box you have verified and confirmed that dimensions, sizes, and quantities are correct. All products will be installed in strict accordance with printed instructions.

Date: _____

DRN BY: **JJC**

CKD BY: **MM**

DWG #: **13010-12162**

REV: **G**

Elevate
26 Century Blvd.
Suite 205
Nashville, TN 37214
Contact your local
Elevate representative.

DIMENSIONS

PRODUCT ID. NO.	H DIM	X DIM	NAILER COVERAGE
<input type="checkbox"/> ESE-M95	9 1/2"	8 3/8"	5 NAILERS
<input type="checkbox"/> ESE-M110	11"	9 7/8"	6 NAILERS
<input type="checkbox"/> ESE-M125	12 1/2"	11 3/8"	7 NAILERS

MATERIAL

- 22 Ga. Galv. Steel
- .050" Aluminum
- .063" Aluminum

Color: _____

Finish: _____

- Substrate:** Wood
 Masonry
 Metal
- If substrate is not given, wood fasteners will be provided.

OTHER: _____

QUANTITIES

_____ Lineal Feet (12'-0" Lengths)

_____ Outside Miter (90°) (Cover Only)

_____ Inside Miter (90°) (Cover Only)