

# PERMA-TITE WELDED RADIUS COPING

TAPERED VERSION

**IMPORTANT!!!** MUST INDICATE PROPER RADIUS CONDITION BY CIRCLING APPROPRIATE OUTSIDE FACE

PROVIDING A RADIUS  
THE RADIUS MAY BE PROVIDED  
IN ONE OF TWO METHODS:

1.) THE ACTUAL KNOWN RADIUS IS

' FEET  " INCHES MINIMUM OF 3'-0"

OR

2.) FIELD CONDITION MEASUREMENTS

NOTE: REFER TO ATTACHED WORKSHEET  
FOR FURTHER INFORMATION

" INCHES

RISE MAXIMUM  
OF 4 <sup>3</sup>/<sub>4</sub>"

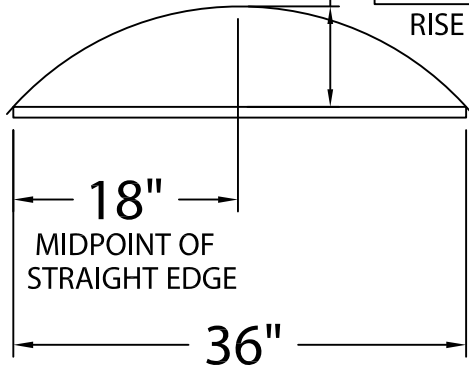

LENGTH OF  
STRAIGHT EDGE

NOTE: CHECK MEASUREMENTS ALONG ENTIRE RADIUS.

DETAIL A

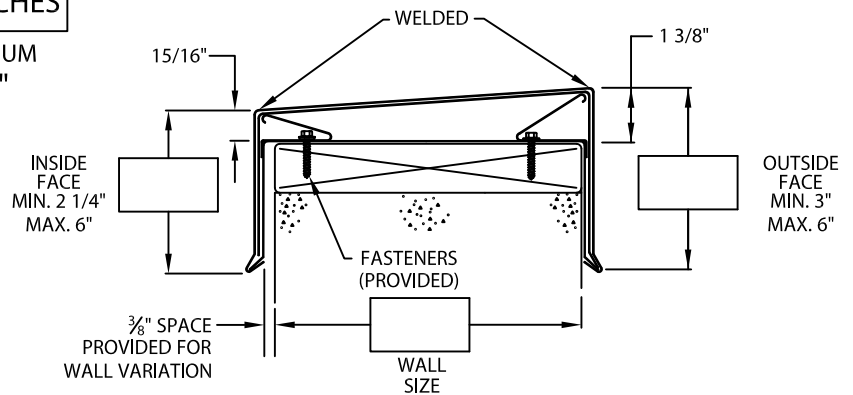
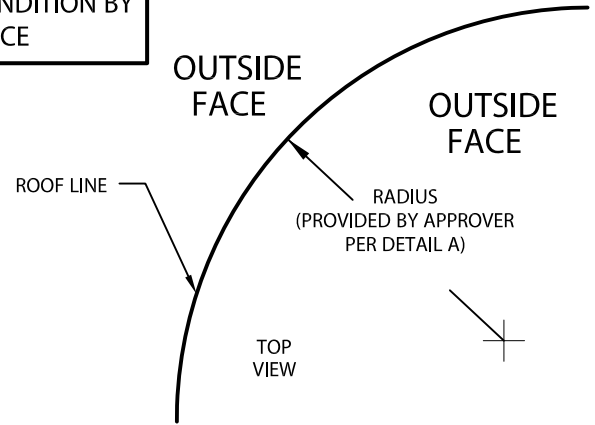

**NOTES:** -- Concealed splice plates are provided with factory applied dual non-curing sealant strips.

## MATERIALS:

Top - .080" Alum.

Sides - .063" Alum.

Color: \_\_\_\_\_

Finish: \_\_\_\_\_

## QUANTITIES:

\_\_\_\_\_ Lineal Feet 4'-0" Lengths

Fabrication will proceed only after receipt of signed print approval.

## Print Approval:

Architect and/or contractor shall verify all dimensions, sizes and quantities. All products to be installed in strict accordance with Johns Manville's printed instructions.

Approved by: \_\_\_\_\_

Date: \_\_\_\_\_

PROJECT:

ARCHITECT:

ROOFING CONTRACTOR:

REPRESENTATIVE/DISTRIBUTOR:

51 Lexington Street; Lewiston, ME 04240

CUSTOMER SERVICE: 800-223-8317 USA

800-445-1500 Canada

TECHNICAL SERVICE: 800-445-1500 USA & Canada

FAX: 207-784-0125

OTHER AREAS CALL: 207-784-0123

**JM** Johns Manville

DATE: 12/20/16

DRN BY: JAB

CKD BY: SAK

SHT.# \_\_\_\_ OF \_\_\_\_

DWG# 16011-6967

**B**