

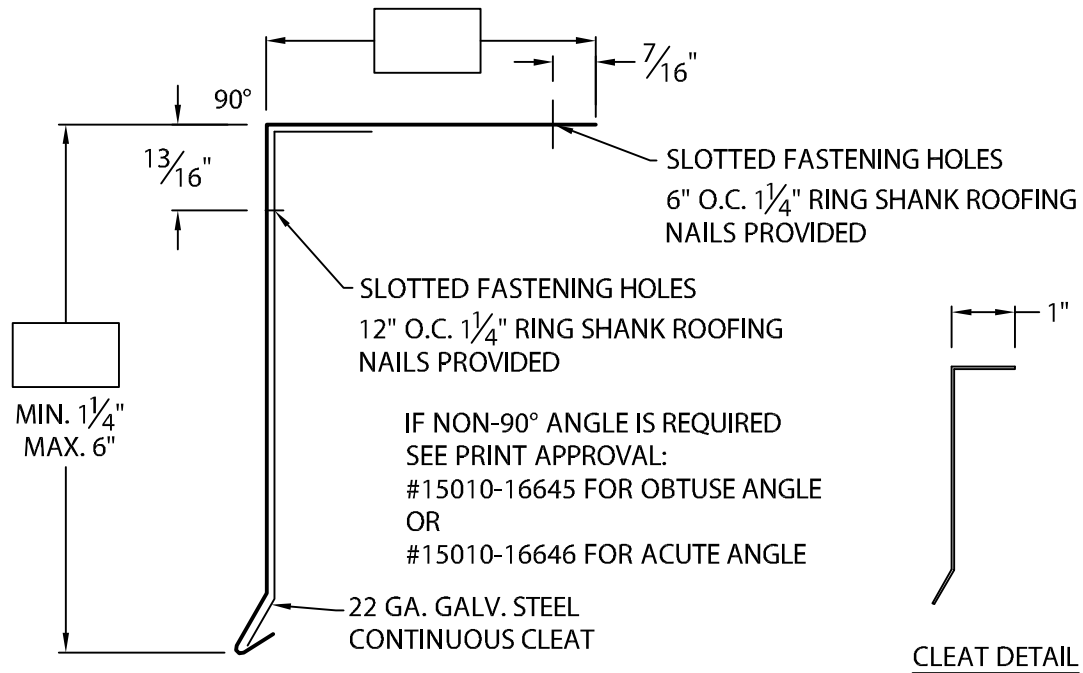

SECUREDGE 200 DRIP EDGE

1 1/4" TO 6" FACE HEIGHT WITH CONTINUOUS CLEAT VERSION

ANSI/SPRI/FM 4435/ ES-1 DESIGN PRESSURE OF 282 psf



NOTES:

- INCLUDES 6" WIDE CONCEALED SPLICE PLATES.
- CONCEALED SPLICE PLATES MUST BE FIELD CAULKED TO PREVENT WATER ENTRY.
- UNLESS OTHERWISE NOTES, FABRICATION OF MITERS AND ACCESSORIES ARE FURNISHED STANDARD UTILIZING A NON-PENETRATING QUICKLOCK JOINT, THEN FACTORY SEALED WATERTIGHT.

Fabrication will proceed only after receipt of signed print approval.

Print Approval:

Architect and/or contractor shall verify all dimensions, sizes and quantities. All products to be installed in strict accordance with Carlisle SynTec, Inc.'s printed instructions.

Approved by: _____

Date: _____

FOR FACE SIZES OVER 6" SEE PRINT APPROVAL #15010-24902

-- WELDED MITERS AND ACCESSORIES

CHECK ONE REQUIRED (SURCHARGE) NOT APPLICABLE

MATERIAL:

- ____ 24 GA. GALVANIZED STEEL
- ____ .040" ALUMINUM COLOR: _____
- ____ .050" ALUMINUM
- ____ .063" ALUMINUM FINISH: _____
- ____ OTHER _____

QUANTITIES:

- ____ LINEAL FEET 12'-0" LENGTHS
- ____ OUTSIDE MITERS @ 90°
- ____ INSIDE MITERS @ 90°

FOR NON 90° MITERS SEE PRINT APPROVAL #15010-1625

PROJECT:

ARCHITECT:

ROOFING CONTRACTOR:

REPRESENTATIVE/DISTRIBUTOR:

Customer Service
866-458-3537
(Metal-Era)



DATE: 09/23/16

DRN BY: JJC

CKD BY: SAK

SHT.# ____ OF ____

DWG# 15010-1669

F