

SECUREDGE ONE COPING

FLAT OR EXISTING SLOPE VERSION

INSTALLATION INSTRUCTIONS

IMPORTANT: Prior to installation, read instructions carefully.

NOTE: Position roof membrane on top of the wall covering the treated wood nailer(s) or substrate completely. Allow 1/2" minimum excess membrane beyond nailer where applicable. NRCA requirement. Membrane not shown for clarity.

CAUTION: INSTALL MITERS FIRST!

NOTE: Fasteners to meet minimum of #240 pull-out for substrate.

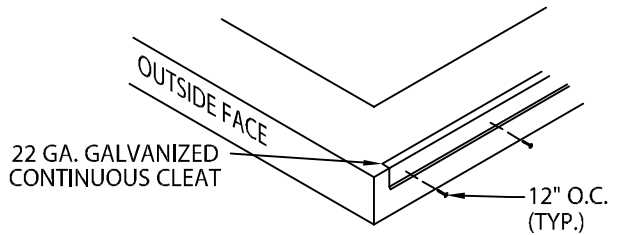

STEP 1 - CONTINUOUS CLEAT

PLACE A 12'-0" LENGTH OF CONTINUOUS CLEAT ON THE OUTSIDE FACE ALONG THE WALL. FASTEN CLEAT INTO SUBSTRATE THRU FACE OF CLEAT WITH PROVIDED NAILS AT 12" O.C.

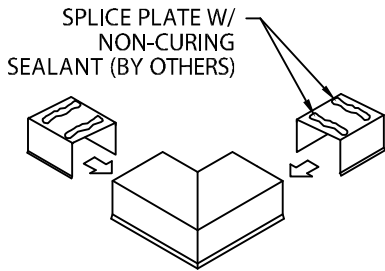

STEP 2 - MITER SPLICE PLATES

FIELD APPLY SEALANT (BY OTHERS) TO TOP OF EACH SPLICE PLATE AS SHOWN. INSTALL THE SPLICE PLATE HALFWAY INTO EACH END OF THE MITER AS SHOWN.

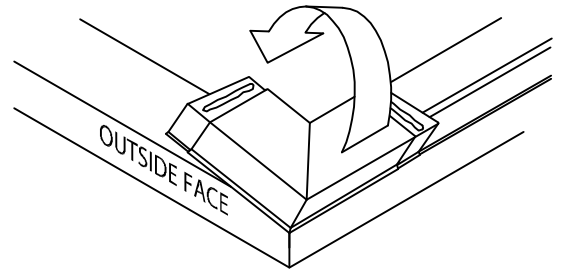

STEP 3 - MITER ASSEMBLY

HOOK OUTSIDE FACE OF MITER ASSEMBLY ONTO BOTTOM OF CONTINUOUS CLEAT AND ROTATE INTO PLACE AS SHOWN.

STEP 4 - CONTINUOUS CLEAT

SLIDE SECOND 12'-0" SECTION OF CONTINUOUS CLEAT UNDER THE OTHER LEG OF MITER COVER, INSURING THAT THE DRIP OF THE CLEAT IS ENGAGED TO THAT OF THE COVER. FASTEN CLEAT AS IN STEP 1. DRILL AND FASTEN THROUGH INSIDE FACE OF COVER TO NAILER WITH PROVIDED #10 x 1 1/2" STAINLESS STEEL FASTENERS.

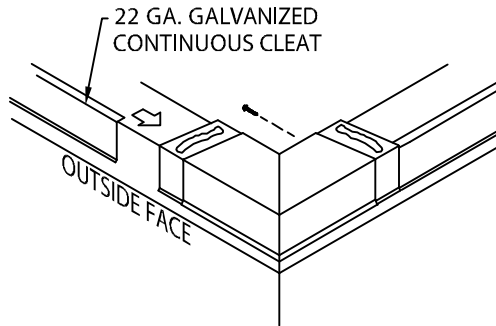

TYPICAL INSTALLATION

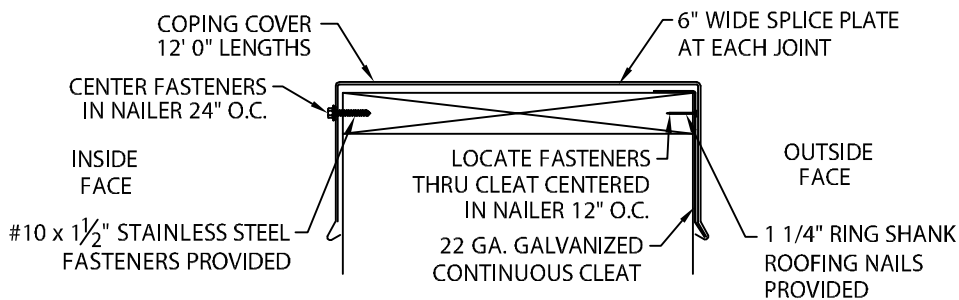

Customer Service
866-458-3537
(Metal-Era)

DATE: 04/04/16
DRN BY: JJC
CKD BY: SAK

SHT.# 1 OF 2
DWG# 15111-10778

B

SECUREDGE ONE COPING

FLAT OR EXISTING SLOPE VERSION

INSTALLATION INSTRUCTIONS

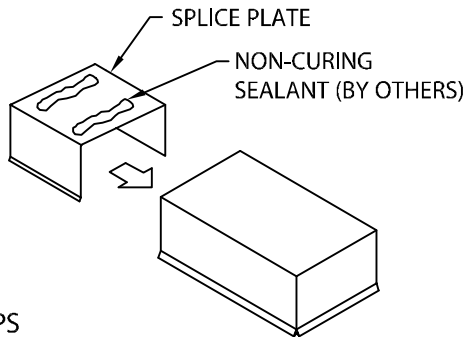

STEP 5 - ENDCAPS

LOCATE AND ATTACH CLEAT AS IN STEP 1. FIELD APPLY SEALANT (BY OTHERS) TO TOP OF EACH SPLICE PLATE AS SHOWN. INSTALL THE SPLICE PLATE ASSEMBLY HALFWAY INTO END OF THE ENDCAP AS SHOWN.

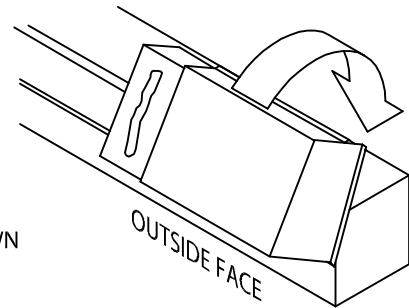

STEP 6 - ENDCAPS (CONT.)

HOOK OUTSIDE FACE OF ENDCAP ONTO THE CONTINUOUS CLEAT AND ROTATE INTO PLACE. FASTEN INSIDE FACE WITH PROVIDED SCREWS.

STEP 7 - CONTINUOUS CLEAT

POSITION 12'-0" CONTINUOUS CLEAT SECTIONS THEN FASTEN 12" O.C. AS SHOWN WITH PROVIDED NAILS. LAP CLEAT 1" AT JOINTS. INSERT ONE SPLICE PLATE UNDER END OF 12'-0" COPING SECTION WITH SEALANT, TO BE FIELD APPLIED TO TOP OF EACH SPLICE PLATE AS SHOWN. ROTATE COPING INTO PLACE.

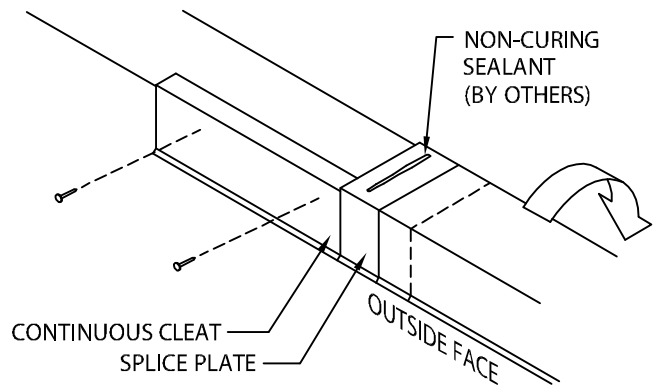

STEP 8 - COPING

INSTALL 12'-0" COPING SECTIONS. HOOK DRIP EDGE OF EACH COPING SECTION ONTO CONTINUOUS CLEAT, ROTATE INTO PLACE.

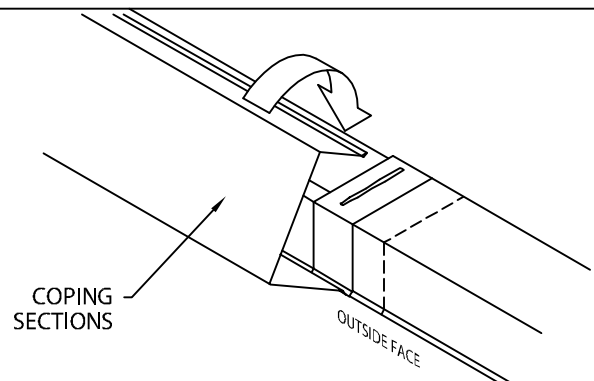

CAUTION:
REMOVE PROTECTIVE FILM IMMEDIATELY AFTER INSTALLATION. INSTALLERS SHALL WEAR PROTECTIVE EYEWEAR TO PREVENT INJURY.

STEP 9 - COMPLETION

LEAVE A 3/8" GAP BETWEEN COVER SECTIONS TO ALLOW FOR THERMAL EXPANSION. FASTEN INSIDE FACE OF COVER WITH PROVIDED #10 x 1 1/2" STAINLESS STEEL FASTENERS 12" FROM EDGE AND 24" O.C. DOWN LENGTH OF COPING COVER. FIELD CUT WHERE NECESSARY USING A FINE TOOTH HACKSAW OR SNIPS.

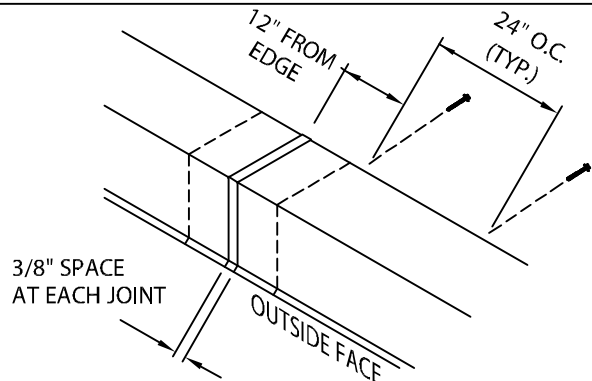

Customer Service
866-458-3537
(Metal-Era)

DATE: 04/04/16
DRN BY: JJC
CKD BY: SAK

SHT.# 2 OF 2
DWG# 15111-10778

B