



SECUREEDGE ONE

FULLY ADHERED OR MECHANICALLY ATTACHED SINGLE-PLY VERSION

LAP JOINT VERSION INSTALLATION INSTRUCTIONS

FOR RADIUS INSTALLATION INSTRUCTIONS SEE PAGE 5

TYPICAL INSTALLATION FOR 12'-0" STRAIGHT COVER

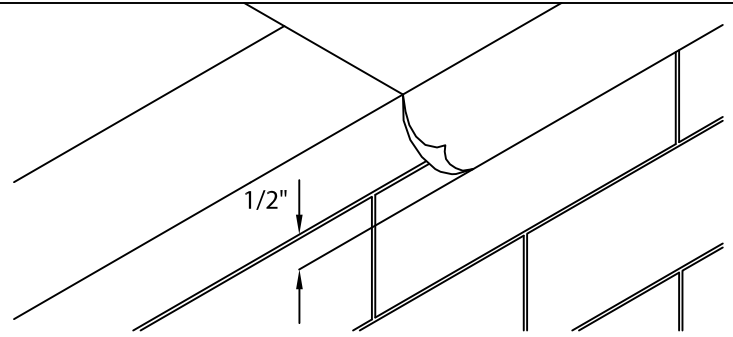
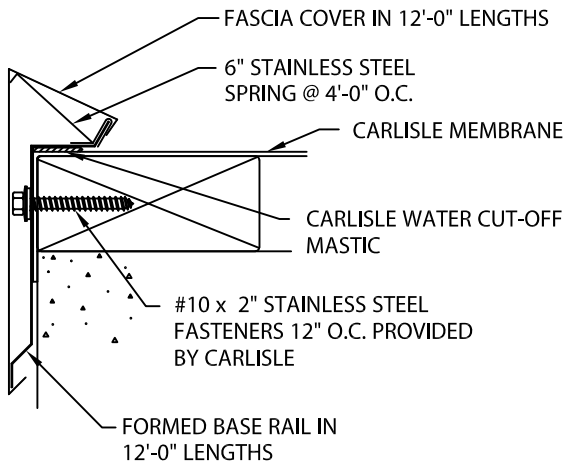

STEP 1 - MEMBRANE

POSITION MEMBRANE OVER THE ROOF EDGE AND DOWN THE OUTSIDE FACE OF THE WALL, OVERLAPPING THE NAILER(S) BY AT LEAST 1/2".

IMPORTANT! Outside edge of treated wood nailer(s) (minimum 2 x 4) shall be aligned flush with or extend slightly past outermost edge of wall. Securedge One Fascia is for use as a perimeter securement on roof designs where the product is not installed in a waterline. If the product will be in a waterline or requires drainage over the edge, we would recommend the use of Securedge 2000 Canted Fascia or Securedge 2000 Drip Edge, depending on desired retention of water or drainage.

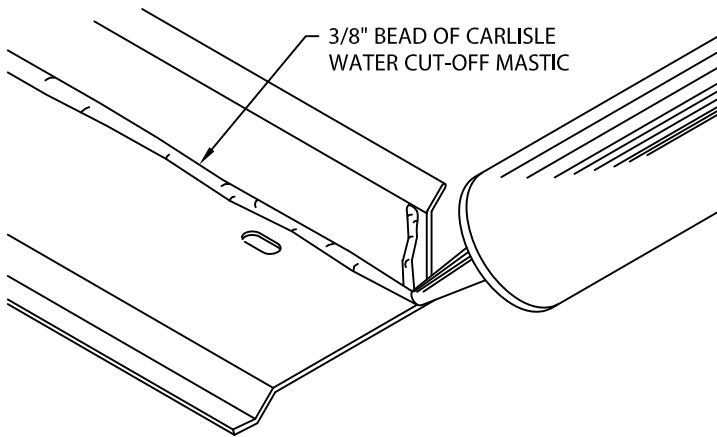

BASE RAIL SHOWN WITH INSIDE FACE UP.

STEP 2 - MITER & SCUPPER BASE RAIL (PREPARATION)

LAY THE BASE RAIL ON THE DECK WITH THE OUTSIDE FACE DOWN. IF NECESSARY, CLEAN THE BACK SIDE OF THE BASE RAIL OF DUST OR DIRT. APPLY A HEAVY 3/8" BEAD OF CARLISLE WATER CUT-OFF MASTIC TO THE RIGHT ANGLE INTERSECTION OF THE DECK FLANGE AND BASE RAIL FOR THE ENTIRE BASE RAIL LENGTH OF AS SHOWN. APPLY A SIMILAR 3/8" BEAD OF MASTIC TO THE BOTTOM OF THE FLANGE'S LEFT END, AS YOU LOOK AT THE OUTSIDE FACE OF THE BASE RAIL SECTION.

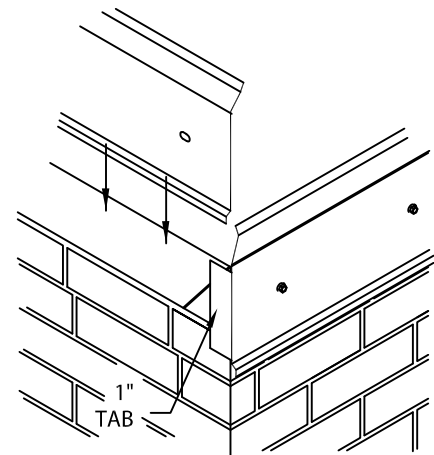

STEP 3 - RAIL MITER PREPARATION

SEE PAGE 4 FOR MITER PREPARATION. FASTEN MITER BASE RAIL TO NAILER(S) THROUGH BASE RAIL SLOTS WITH PROVIDED FASTENERS.



Customer Service
866-458-3537
(Metal-Era)

DATE: 09/11/19
DRN BY: ZS
CKD BY: JAI

SHT.# 1 OF 5
DWG# 15110-10769

H



SECUREDGE ONE

FULLY ADHERED OR MECHANICALLY ATTACHED SINGLE-PLY VERSION

LAP JOINT VERSION INSTALLATION INSTRUCTIONS

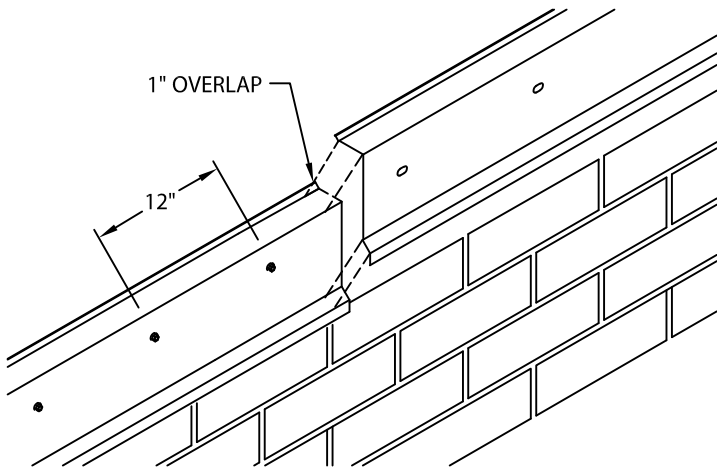

STEP 4 - BASE RAIL INSTALLATION

INSTALL 12'-0" SECTION OF BASE RAIL FROM RIGHT TO LEFT AS SEEN FROM ROOF TOP, LAPPING THE PREVIOUS SECTION 1". FASTEN BASE RAIL TO NAILER(S) THROUGH BASE RAIL SLOTS 12" O.C. WITH PROVIDED FASTENERS. FIELD CUT THE BASE RAIL SECTIONS AS NEEDED.

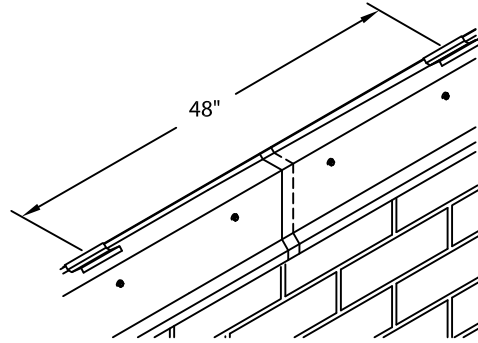

STEP 5 - SPRING CLIPS

PLACE SPRINGS 4'-0" O.C., MAKING SURE THERE WILL BE A SPRING CLIP UNDER EACH FASCIA COVER END.

STEP 6 - FASCIA MITER COVERS

POSITION 6" WIDE STAINLESS STEEL SPRING AT EACH END OF FASCIA MITER COVER (2 TOTAL). INSTALL 2-PIECE "SNAP-ON" FASCIA MITER COVERS FIRST BY SNAPPING ON FASCIA CORNER MITER WITH 90° (DEGREE) TAB, FOLLOWED BY FASCIA COVER WITHOUT THE TAB. SIMPLY POSITION THE COVER ABOVE THE RAIL AND WITH PALM OF HAND APPLY SLIGHT PRESSURE DOWNWARD UNTIL ENGAGED TO THE BOTTOM OF BASE RAIL. REMOVE PROTECTIVE FILM FROM MITER COVERS.

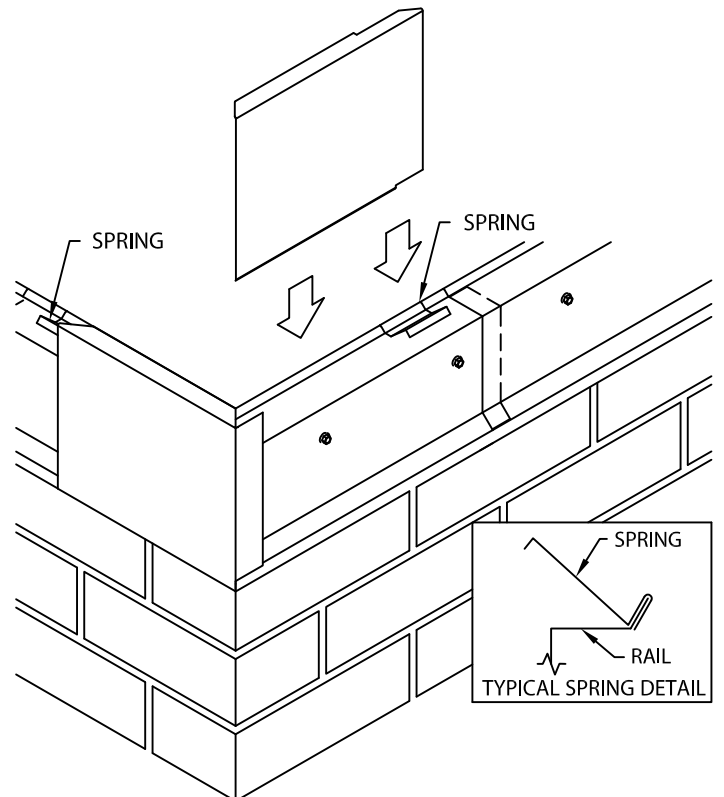

Customer Service
866-458-3537
(Metal-Era)

DATE: 09/11/19
DRN BY: ZS
CKD BY: JAI

SHT.# 2 OF 5
DWG# 15110-10769

H

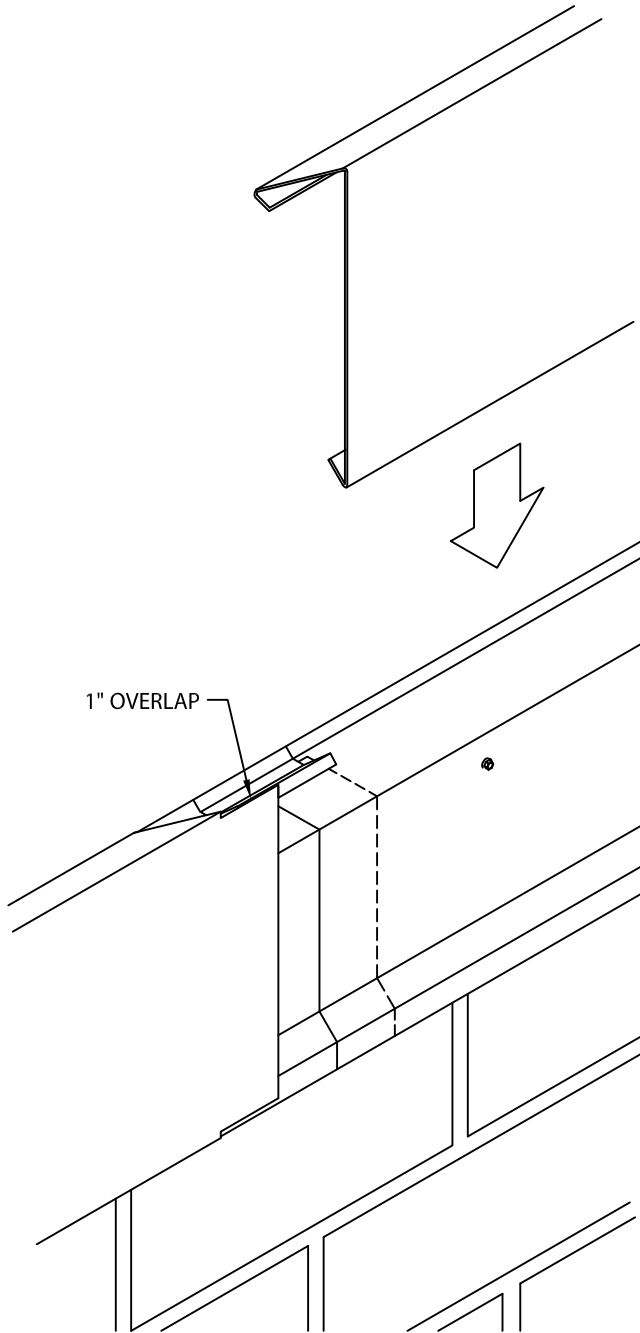

STEP 7 - FASCIA COVERS

REMOVE THE PROTECTIVE FILM FROM FASCIA COVERS. PLACE 12'-0" COVERS ON TOP OF BASE RAIL, LAPPING PRECEDING COVER 1", AGAIN INSTALLING RIGHT TO LEFT AS PER STEP 4 ON PAGE 2. POSITION THE COVERS ABOVE THE RAIL. SNAP EACH COVER ONTO BASE RAIL BY PRESSING DOWN WITH THE PALM OF YOUR HAND UNTIL THE COVER IS FULLY ENGAGED TO THE BOTTOM OF BASE RAIL, ALONG THE ENTIRE COVER LENGTH. FIELD CUT COVERS AS REQUIRED WITH A FINE TOOTH HACKSAW OR SNIPS.



SECUREDGE ONE

FULLY ADHERED OR MECHANICALLY ATTACHED SINGLE-PLY VERSION

LAP JOINT VERSION INSTALLATION INSTRUCTIONS

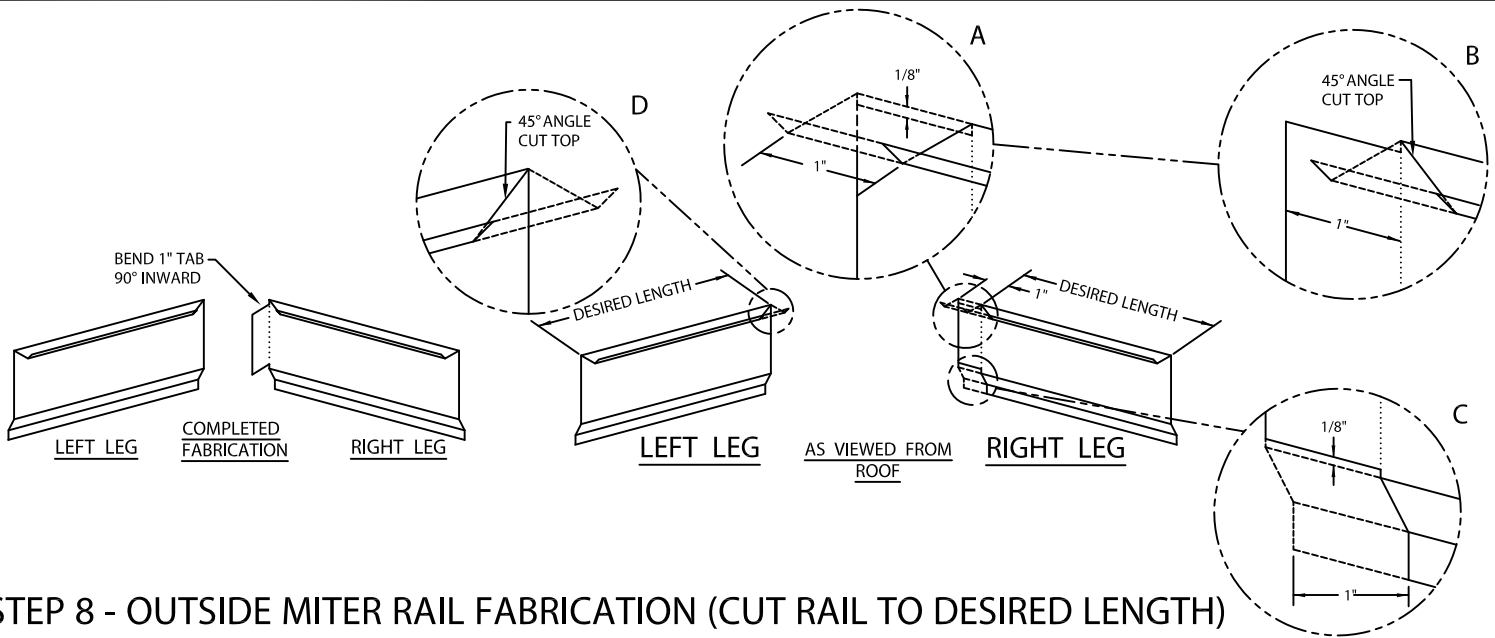

STEP 8 - OUTSIDE MITER RAIL FABRICATION (CUT RAIL TO DESIRED LENGTH)

RIGHT LEG - DETAIL A: FIRST REMOVE A 1" SECTION FROM TOP FLANGE, 1/8" DOWN FACE AND 1" HORIZONTALLY AS SHOWN TO CREATE TAB. DETAIL B: CUT TOP FLANGE AT A 45° ANGLE. DETAIL C: CUT OFF BOTTOM FACE 1/8" x 1" AS SHOWN AND CONTINUE THROUGH AREA SHOWN ON BOTTOM FLANGE. BEND TAB INWARDS 90°. LEFT LEG - DETAIL D: TRIM TOP FLANGE AT A 45° ANGLE.

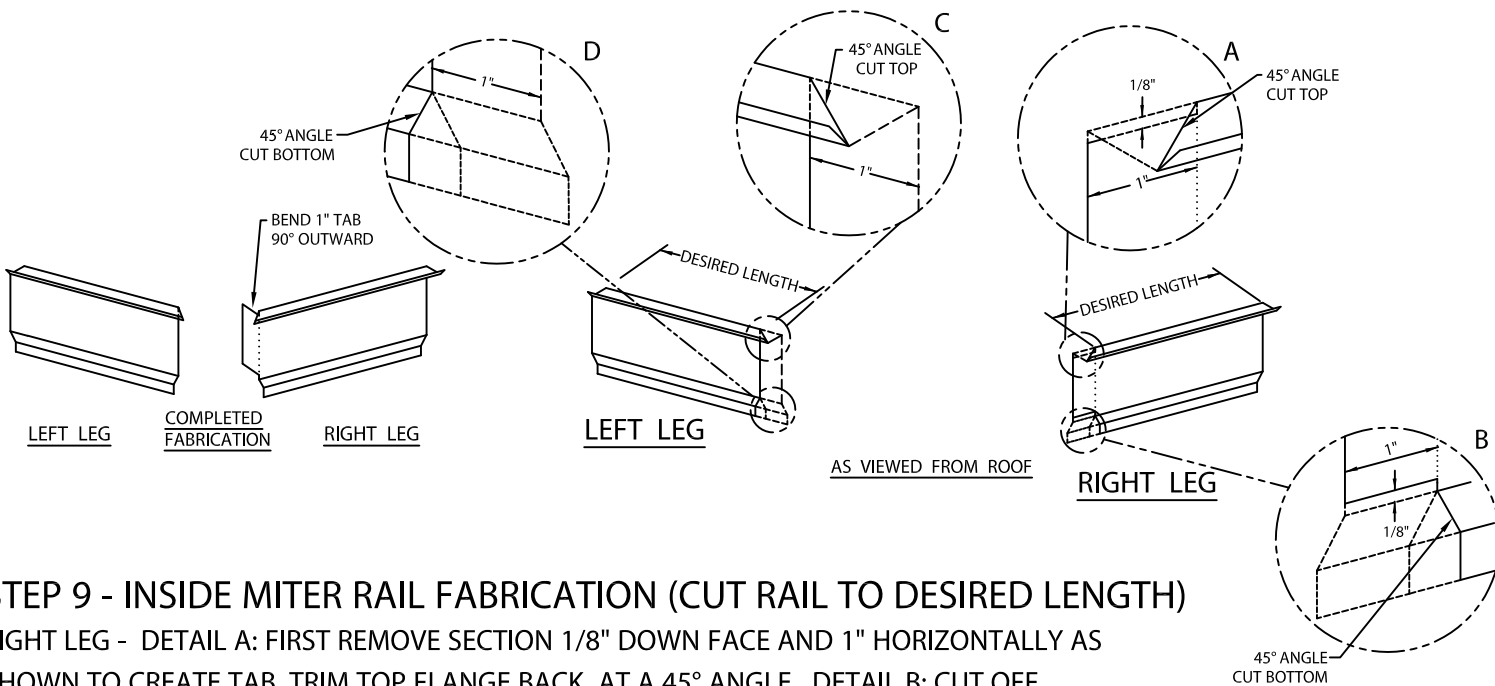

STEP 9 - INSIDE MITER RAIL FABRICATION (CUT RAIL TO DESIRED LENGTH)

RIGHT LEG - DETAIL A: FIRST REMOVE SECTION 1/8" DOWN FACE AND 1" HORIZONTALLY AS SHOWN TO CREATE TAB. TRIM TOP FLANGE BACK AT A 45° ANGLE. DETAIL B: CUT OFF BOTTOM FACE 1/8" AS SHOWN AND CONTINUE CUT AT A 45° THROUGH AREA SHOWN ON BOTTOM FLANGE. BEND TAB INWARDS 90°. LEFT LEG - DETAIL C: CUT TOP FLANGE AT A 45° ANGLE. CONTINUE DOWN FACE. DETAIL D: CUT BOTTOM FLANGE AT 45° ANGLE AS SHOWN.



Customer Service
866-458-3537
(Metal-Era)

DATE: 09/11/19
DRN BY: ZS
CKD BY: JAI

SHT.# 4 OF 5
DWG# 15110-10769

H



RADIUS INSTALLATION INSTRUCTIONS

TYPICAL INSTALLATION

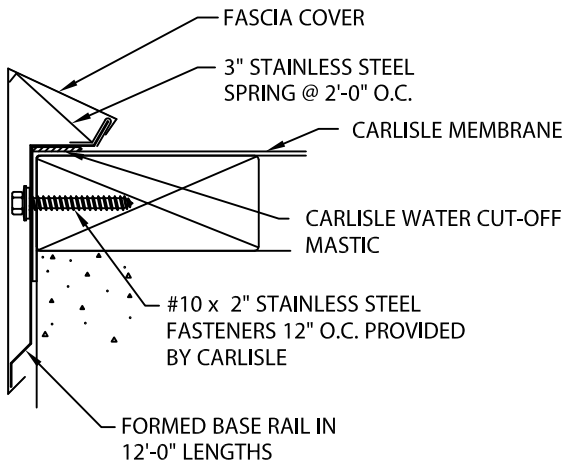

STEP 1

FOLLOW DIRECTIONS ON PAGE 1 FOR INSTALLING CARLISLE MEMBRANE & RAIL.

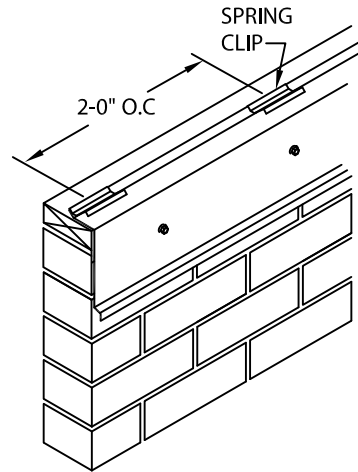

STEP 2 - SPRING CLIPS

LOCATE 3" WIDE SPRING CLIPS, STARTING WITH ONE AT THE END OF RAIL, THEN AT EVERY 2'-0" O.C., MAKING SURE THERE WILL BE A SPRING CLIP UNDER EACH FASCIA COVER END.

STEP 3 - FASCIA COVERS

REMOVE THE PROTECTIVE FILM FROM FASCIA COVERS. PLACE COVERS ON TOP OF BASE RAIL, LAPPING PRECEDING COVER 1", AGAIN INSTALLING RIGHT TO LEFT AS PER STEP 7 ON PAGE 3. POSITION THE COVERS ABOVE THE RAIL. SNAP EACH COVER ONTO BASE RAIL BY PRESSING DOWN WITH THE PALM OF YOUR HAND UNTIL THE COVER IS FULLY ENGAGED TO THE BOTTOM OF BASE RAIL, ALONG THE ENTIRE COVER LENGTH. FIELD CUT COVERS AS REQUIRED WITH A FINE TOOTH HACKSAW OR SNIPS.

