

SECUREDGE 200 COPING MITERS

QUICKLOCK MITER ASSEMBLY

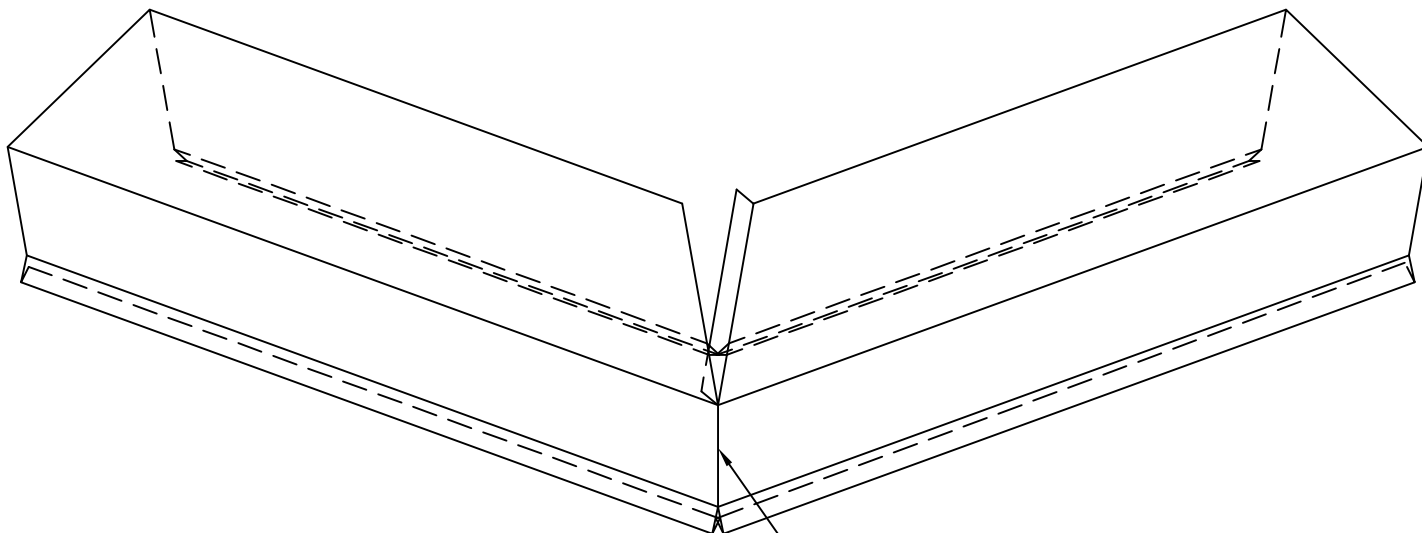

1. MITER IS LAYED OUT AS 1 PC IN THE FLAT, FORMED, THEN FOLDED AT FRONT FACE.

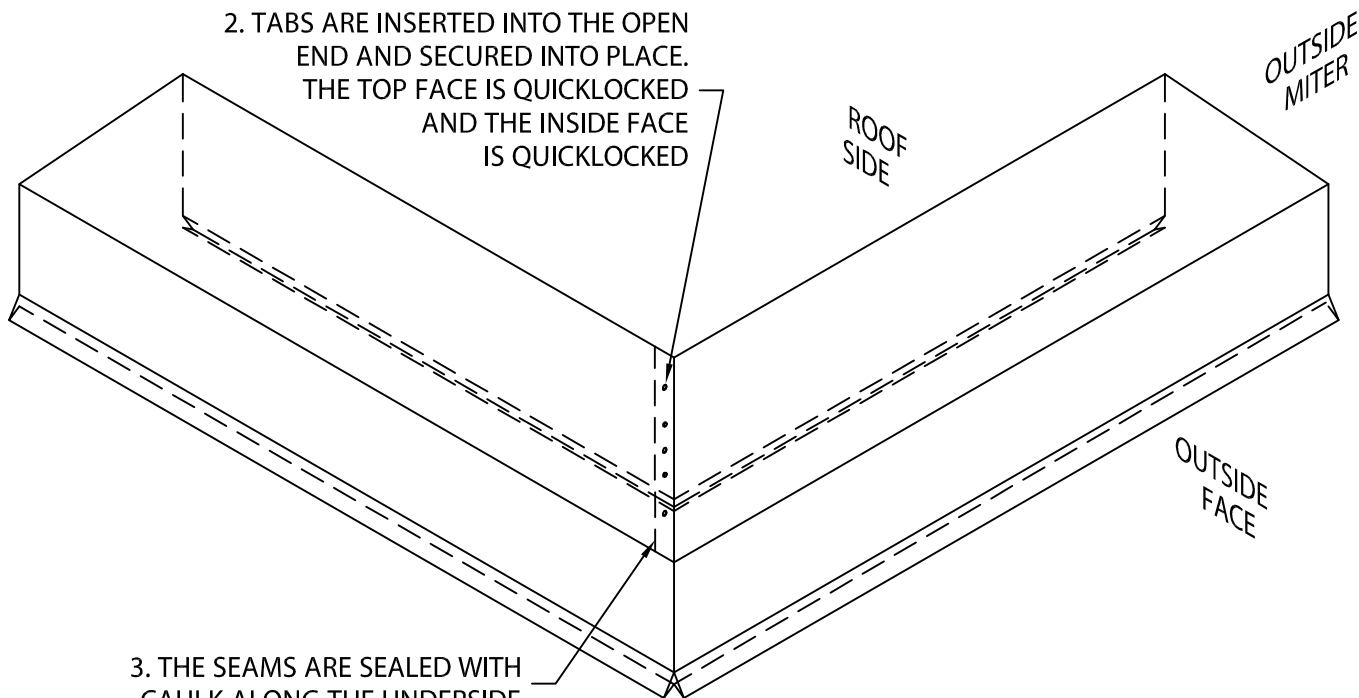

2. TABS ARE INSERTED INTO THE OPEN END AND SECURED INTO PLACE. THE TOP FACE IS QUICKLOCKED AND THE INSIDE FACE IS QUICKLOCKED

3. THE SEAMS ARE SEALED WITH CAULK ALONG THE UNDERSIDE

NON-WELDED MITERS ARE FABRICATED WITH OPEN OUTSIDE CORNERS