

LG GUTTER

IG-B VERSION

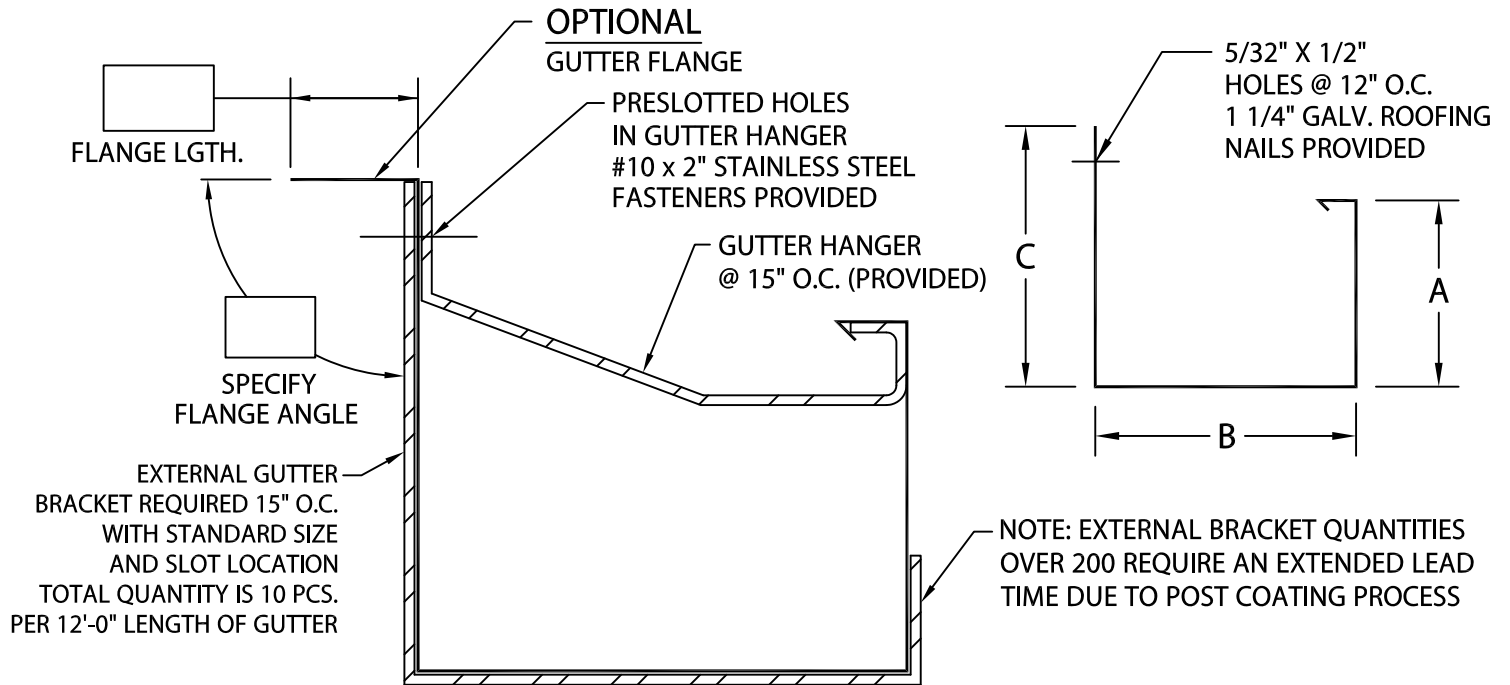

PRODUCT ID #	C	B	A	HANGER
<input type="checkbox"/> IGB-C10	10"	9"	9"	2" x .100 Mill
<input type="checkbox"/> IGB-C11	11"	10"	10"	2" x .100 Mill
<input type="checkbox"/> IGB-C12	12"	11"	11"	2" x .100 Mill
<input type="checkbox"/> IGB-C13	13"	12"	12"	2" x .100 Mill

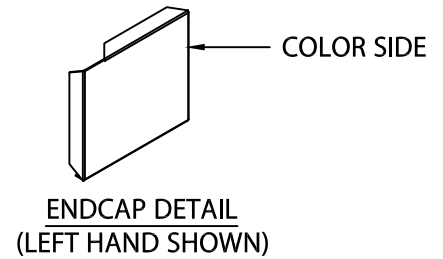

NOTES:

- MAXIMUM DOWNSPOUT DIMENSION NOT TO EXCEED "B" MINUS 9/16".
- 2" LAP JOINTS PROVIDED.
- 1/8" STAINLESS STEEL POP RIVETS PROVIDED.
- UNLESS OTHERWISE NOTED, FABRICATION OF MITERS ARE FURNISHED STANDARD UTILIZING A NON-PENETRATING QUICKLOCK JOINT, THEN FACTORY SEALED WATERTIGHT.
- WELDED ACCESSORIES REQUIRE A MINIMUM MATERIAL THICKNESS OF .050".

Fabrication will proceed only after receipt of signed print approval.

Print Approval:

Architect and/or contractor shall verify all dimensions, sizes and quantities. All products to be installed in strict accordance with Metal-Era's printed instructions.

Approved by: _____

Date: _____

MATERIAL:

___ 22 GA. GALV. STEEL ___ .063" ALUMINUM
 ___ .050" ALUMINUM ___ OTHER _____

(NOT AVAILABLE IN 24 GA. GALV. STEEL OR .040" ALUMINUM)

COLOR: _____ FINISH: _____

QUANTITIES:

_____ LINEAL FEET 12'-0" LENGTHS SPECIFY MITER TYPE:
 _____ OUTSIDE MITERS @ 90° WELDED
 _____ INSIDE MITERS @ 90° QUICKLOCK
 _____ ENDCAPS: RIGHT _____ LEFT _____
 _____ EXPANSION JOINTS
 STYLE "1" ___ STYLE "2" ___

FOR NON-90 MITERS SEE PRINT APPROVAL #11012-10010

PROJECT:	Corporate Offices, Manufacturing 1600 Airport Road; Waukesha, WI 53188 Phone: 800-558-2162 Fax: 800-373-9156 www.metalera.com
ARCHITECT:	
ROOFING CONTRACTOR:	
REPRESENTATIVE/DISTRIBUTOR:	



DATE: 10/04/21	SHT.# _____ OF _____
DRN BY: JJC	DWG# 11012-37207 A
CKD BY: MM	

EXTERNAL GUTTER BRACKET

IG-B VERSION

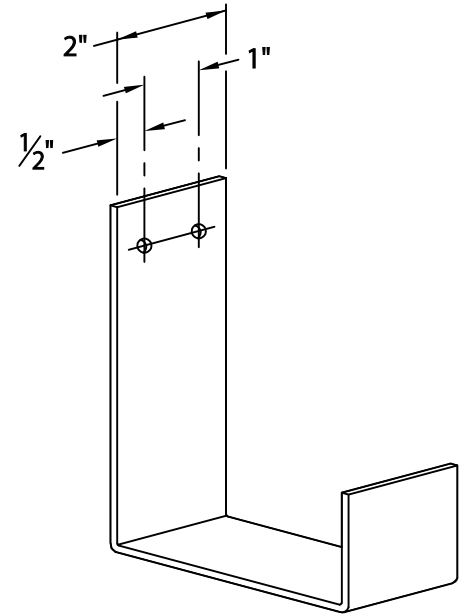
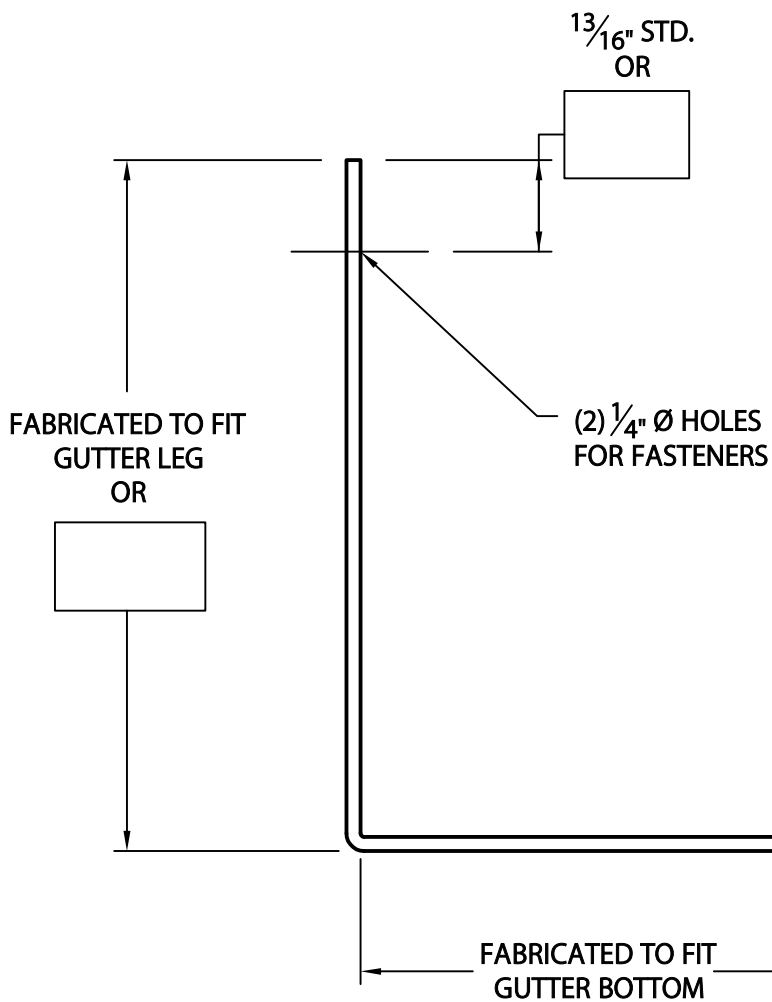

ISOMETRIC VIEW

2" WIDE BRACKET

Fabrication will proceed only after receipt of signed print approval.

Print Approval:

Architect and/or contractor shall verify all dimensions, sizes and quantities. All products to be installed in strict accordance with Metal-Era's printed instructions.

Approved by: _____

Date: _____

MATERIAL:

.125" ALUMINUM

COLOR: _____

FINISH: _____

QUANTITIES:

_____ AMOUNT REQUIRED*

*QUANTITIES OVER 200 REQUIRE AN EXTENDED LEAD TIME DUE TO POST COATING PROCESS.

PROJECT:

ARCHITECT:

ROOFING CONTRACTOR:

REPRESENTATIVE/DISTRIBUTOR:

Corporate Offices, Manufacturing
1600 Airport Road; Waukesha, WI 53188
Phone: 800-558-2162
Fax: 800-373-9156
www.metalera.com



DATE: 11/23/21

DRN BY: JJC

CKD BY: MM

SHT.# _____ OF _____

DWG# 11012-1509

E