

GUTTER EXPANSION JOINT (STYLE 1)

FOR USE OVER BUILDING CONTROL JOINT

SMACNA DESIGN

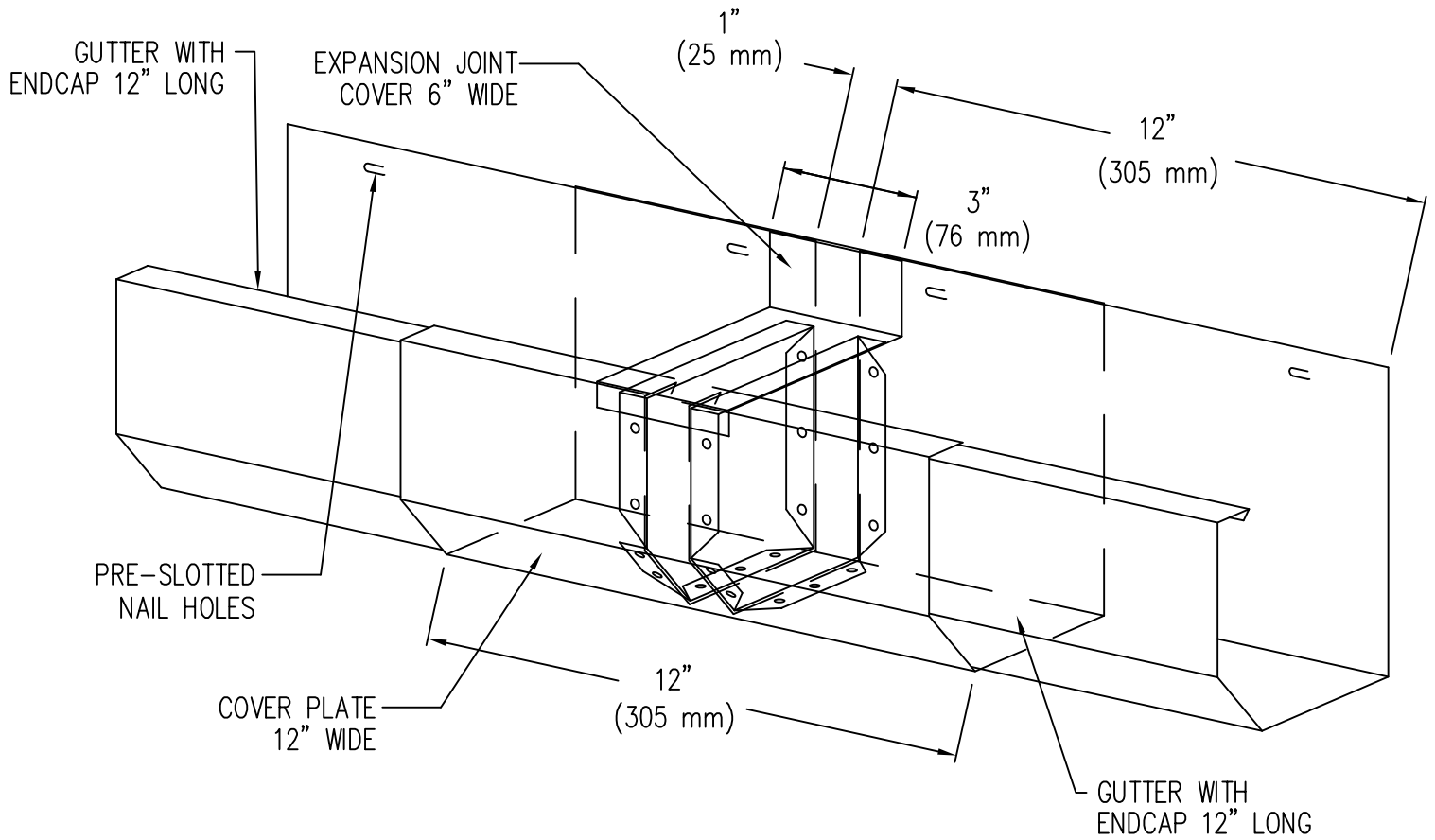

NOTE: IG-2 Shown. Detail will change as to individual gutter systems

Fabrication will proceed only after receipt of signed print approval.

Print Approval:

Architect and/or contractor shall verify all dimensions, sizes, and quantities. All products to be installed in strict accordance with Carlisle SynTec, Inc. printed instructions.

Approved by: _____

Date: _____

MATERIAL:

- ___ 24 Ga. (.65 mm) Galv.
- ___ .040" (1.01 mm) Alum. Color: _____
- ___ .050" (1.27 mm) Alum. Finish: _____
- ___ .063" (1.60 mm) Alum.
- ___ OTHER _____

QUANTITIES:

_____ Quantity Required

PROJECT	Customer Service 888-666-4369 (Metal-Era)
ARCHITECT	
ROOFING CONTRACTOR	
REPRESENTATIVE/DISTRIBUTOR	



DATE: 10/05/05

DRN BY: JJC

CKD BY: SAK

SHT.# ___ OF ___

DWG# 15012-1728

B