

ELEVATE INDUSTRIAL XL GUTTER

BOX VERSION WITH CB-90 TERMINATION BAR

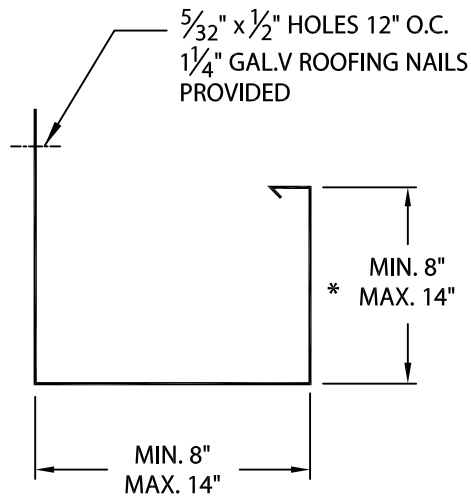
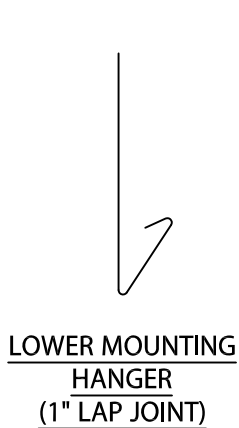
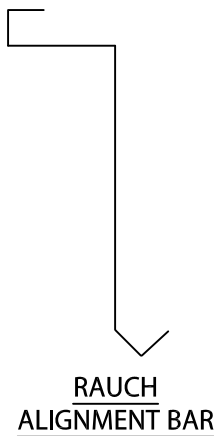
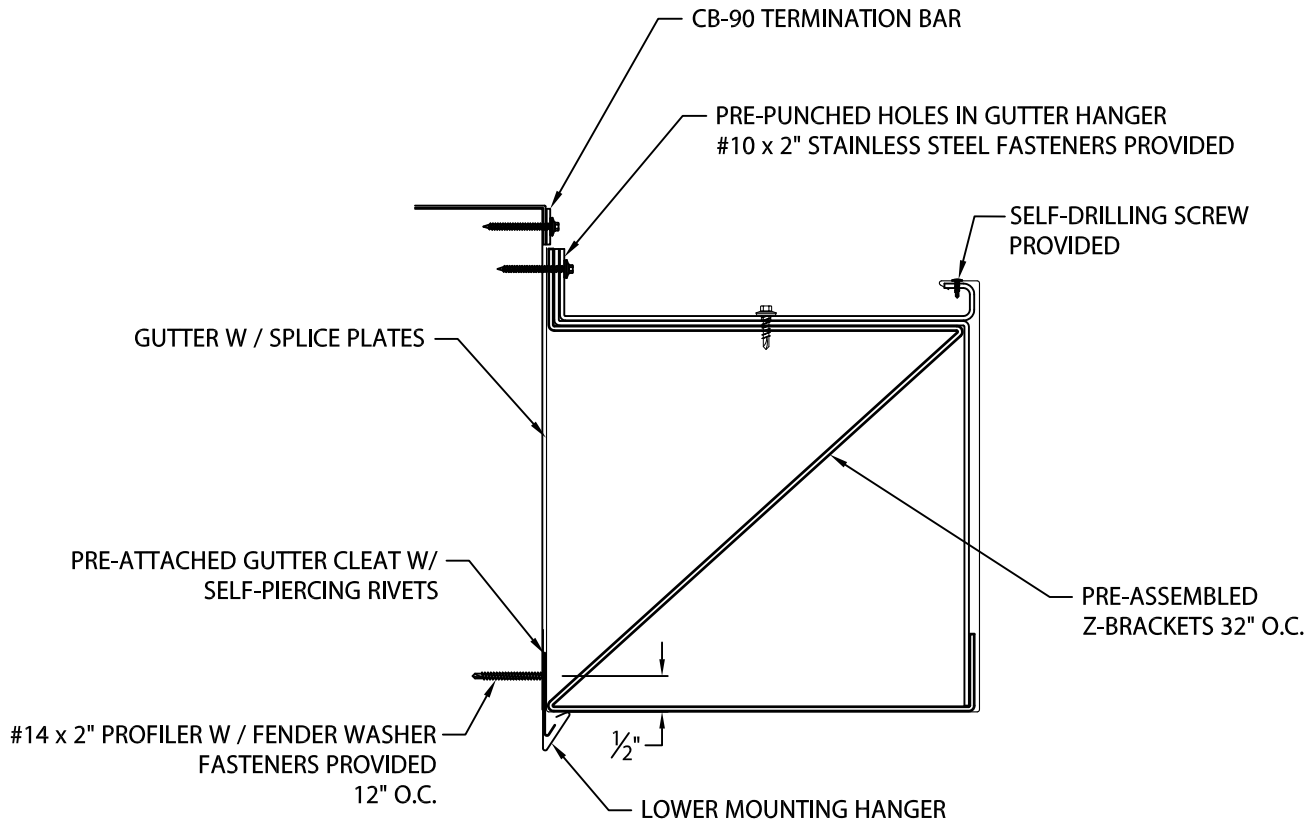

FRONT FACE
HEIGHT MUST
MATCH BOTTOM
WIDTH

* DIMENSION MUST BE A
MINIMUM 1" LESS THAN
BACKER HEIGHT



ELEVATE
 26 CENTURY BLVD.
 SUITE 205
 NASHVILLE, TN 37214
 CONTACT YOUR LOCAL ELEVATE REPRESENTATIVE

DATE: 08/15/23
 DRN BY: MLM
 CKD BY: MM

SHT.# ___ OF ___
 DWG# 13512-41340

A