

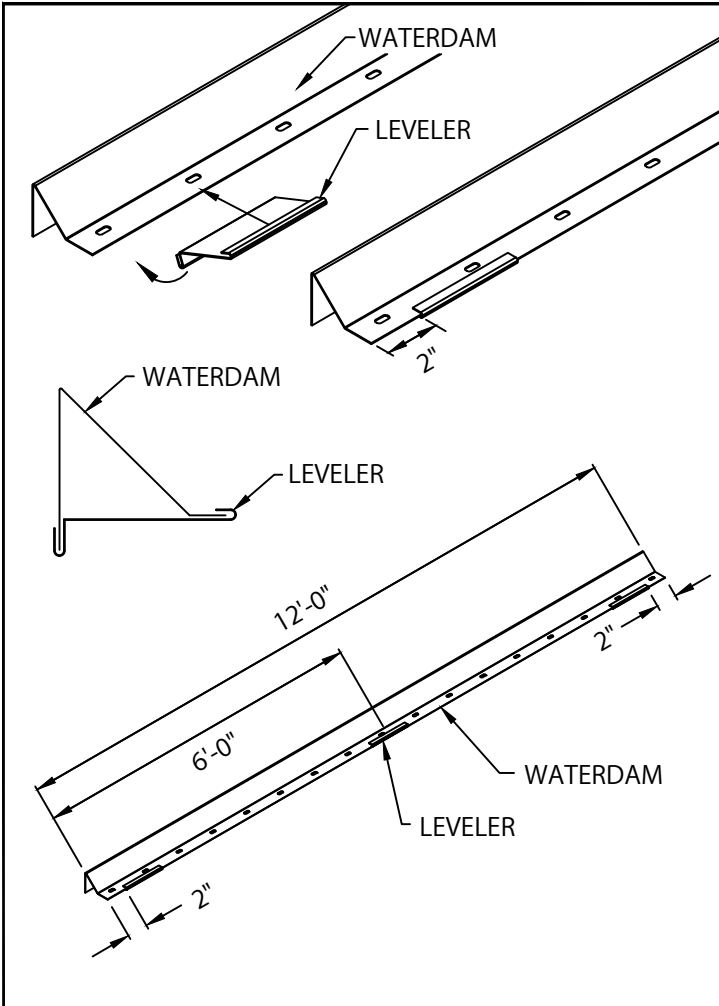

# VERSITRIM 2000 EXTENDED CANTED FASCIA

GALVANIZED WATERDAM VERSION

## INSTALLATION INSTRUCTIONS



### 1. WATERDAM & LEVELER

POSITION LEVELER 2" FROM END OF WATERDAM, HOOKING ONTO WATERDAM AND ROTATING INTO PLACE AS SHOWN. DO THE SAME AT THE OTHER END OF 12'-0" LENGTH OF WATERDAM. ALSO PLACE A LEVELER IN CENTER OF 12'-0" LENGTH (3 LEVELERS PER 12'-0" LONG WATERDAM). DO THE SAME FOR MITERS, 2" FROM END OF WATERDAM (2 LEVELERS PER MITER).

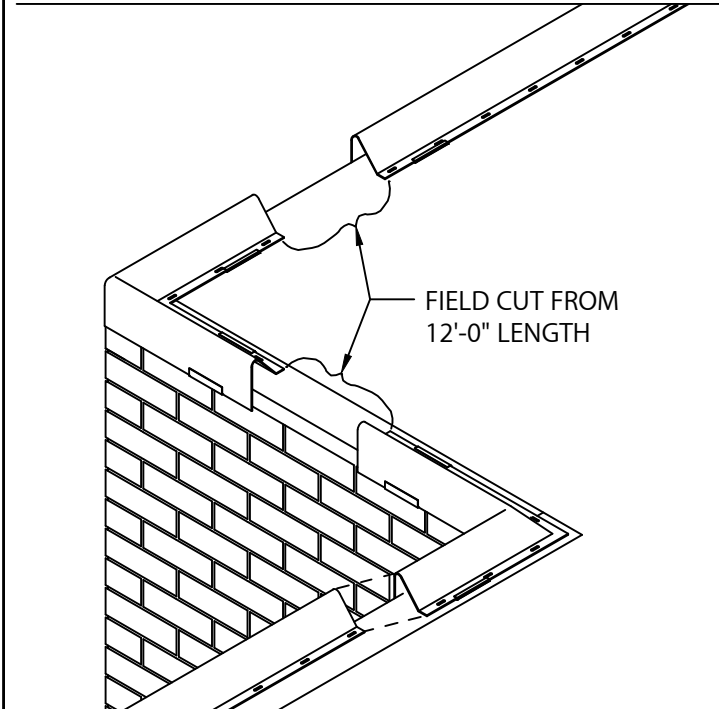

### 2. WATERDAM

LOCATE AND INSTALL WATERDAM MITERS, NAILING THROUGH PRE-SLOTTED FASTENING HOLES ON TOP OF NAILER(S). DETERMINE AND IDENTIFY LOCATIONS OF SCUPPERS AT THIS TIME. LEAVE GAP OF 14<sup>1</sup>/<sub>2</sub>" FOR SCUPPER LOCATIONS. NEXT, INSTALL 12'-0" SECTIONS OF WATERDAM FROM RIGHT TO LEFT (AS SEEN FROM ROOF TOP) BY NAILING THROUGH PRE-PUNCHED HOLES PROVIDED ON TOP OF NAILER(S). BE SURE TO OVERLAP WATERDAM 1".

NOTE: PROVIDED WATERDAM FASTENER: 1<sup>1</sup>/<sub>4</sub>" RING SHANK GALVANIZED ROOFING NAILS.

CAUTION : INSTALLERS SHALL WEAR PROTECTIVE EYEWEAR TO PREVENT SERIOUS INJURY.



Customer Service  
800-558-2162

DATE: 02/21/22  
DRN BY: MLM  
CKD BY: MM

SHT.# 1 OF 5

DWG# 18110-2085

M



# VERSITRIM 2000 EXTENDED CANTED FASCIA

GALVANIZED WATERDAM VERSION

INSTALLATION INSTRUCTIONS

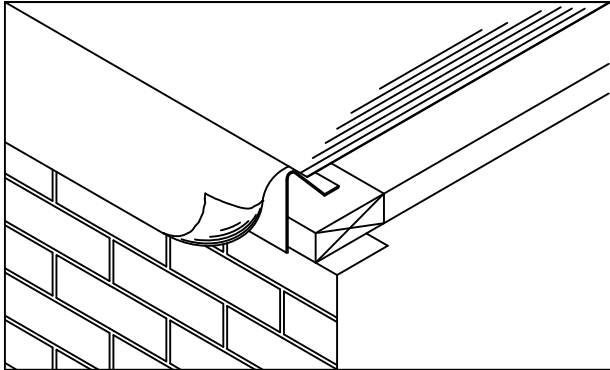

### 3. ROOFING MEMBRANE

FOLLOW GENERAL RECOMMENDATIONS OF THE ROOF MEMBRANE MANUFACTURERS APPLICATION OF MATERIALS OVER THE ROOF EDGE.

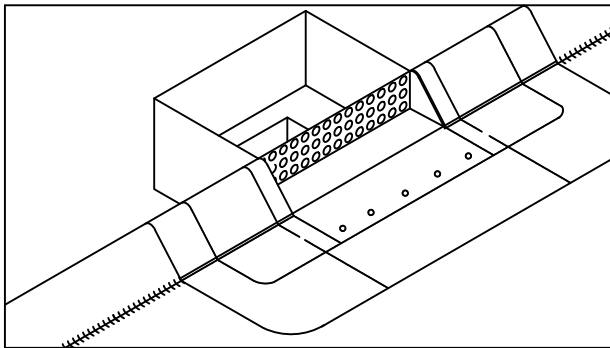

### 4. SCUPPERS

INSTALL SPILLOUT OR DOWNSPOUT SCUPPERS (IF APPLICABLE) AT PREDETERMINED LOCATIONS.

**NOTE :** ROOF MEMBRANE IS INSTALLED UNDER SCUPPER. SCUPPER FLANGE IS SET IN A CONTINUOUS BEAD OF NON-CURING SEALANT.

**NOTE :** FOLLOW GENERAL RECOMMENDATIONS OF THE ROOF MEMBRANE MANUFACTURERS APPLICATION ON STRIPPING IN THE SCUPPER.



Customer Service  
800-558-2162

DATE: 02/21/22  
DRN BY: MLM  
CKD BY: MM

SHT.# 2 OF 5

DWG# 18110-2085

M



# VERSITRIM 2000 EXTENDED CANTED FASCIA

GALVANIZED WATERDAM VERSION

## INSTALLATION INSTRUCTIONS

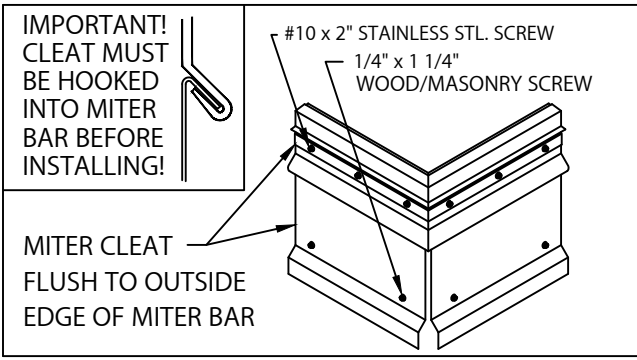

**5. MITER BAR & MITER CLEAT INSTALLATION**  
 HOOK MITER CLEAT PIECES TO MITER BAR. FLUSH ENDS OF MITER CLEAT PIECE AND MITER BAR. INSTALL MITER ASSEMBLY WITH ONE ANCHOR BAR SPLICE PLATE UNDER EACH END OF MITER BAR. FASTEN THE MITER BAR USING 2" HEX HEAD STAINLESS STEEL FASTENERS. FASTENERS AND DRIVE BITS PROVIDED. NEXT LOCATE AND INSTALL THE SPILLOUTS AND SCUPPERS WITH FASTENERS AND SPLICE PLATES.

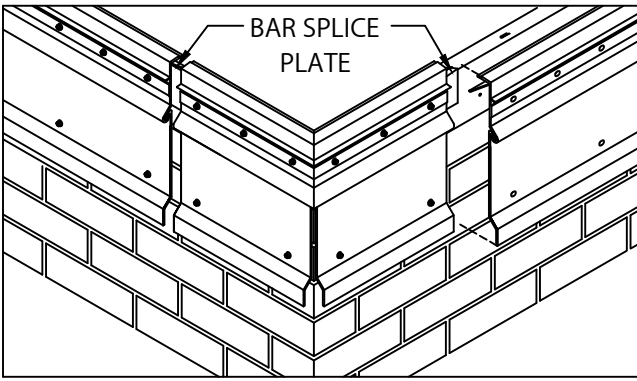

**6. ANCHOR BAR & CLEAT INSTALLATION**  
 HOOK ANCHOR CLEAT TO ANCHOR BAR AS SHOWN IN STEP 4. POSITION 12'-0" ANCHOR BAR/CLEAT SECTIONS OVERLAPPING BAR SPLICE PLATE. ALLOW 3/8" SPACE BETWEEN ANCHOR BARS. INSTALL BAR SPLICE PLATE AT OTHER END OF BAR/CLEAT SECTION. FASTEN ANCHOR BAR 12" O.C. THROUGH THE SLOTTED HOLES USING PROVIDED 2" FASTENERS. FASTEN ANCHOR CLEAT 24" O.C. THROUGH SLOTTED HOLES USING PROVIDED 1 1/4" FASTENERS. FIELD CUT SECTIONS AS IS NECESSARY.

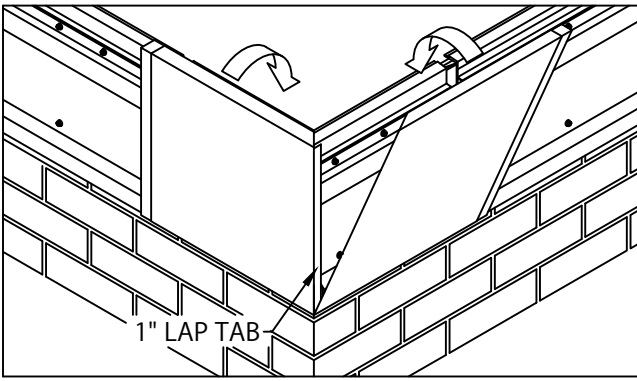

**7. FASCIA MITERS COVERS**  
 INSTALL MITER COVERS FIRST. INSERT ONE SPLICE PLATE UNDER EACH END OF THE TWO PIECE MITER COVER. ENGAGE COVER WITH 90° TAB ONTO BOTTOM OF ANCHOR BAR AND ROTATE MITER COVER UP AND OVER ANCHOR BAR MITER UNTIL ENGAGED ALONG ENTIRE LENGTH OF THE ANCHOR BAR. REPEAT STEPS TO INSTALL MITER COVER WITHOUT THE 90° TAB.

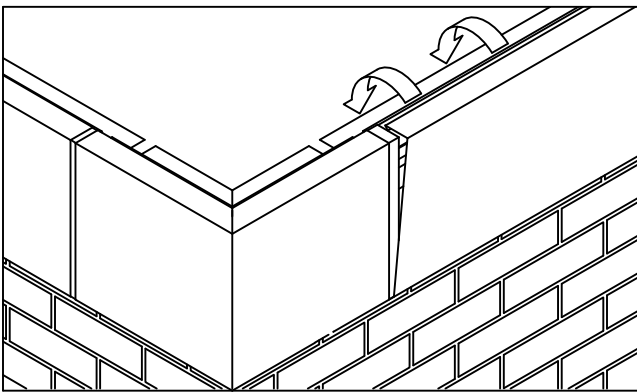

**8. FASCIA COVERS**  
 INSTALL 12'-0" FASCIA COVER SECTIONS. ALLOW A 3/8" GAP BETWEEN FASCIA COVER SECTIONS. INSERT ONE SPLICE PLATE UNDER FAR END OF EACH FASCIA COVER SECTION. INSTALL COVER BY HOOKING LOWER EDGE OF COVER ONTO ANCHOR CLEAT AND ROTATING UP AND OVER ANCHOR BAR UNTIL ENGAGED ALONG ENTIRE LENGTH OF COVER SECTION. CONTINUE TO INSTALL COVER SECTIONS IN THIS MANNER, FIELD CUTTING WHERE NECESSARY USING A FINE TOOTH HACKSAW.

**IMPORTANT !**  
 BE SURE TO REMOVE PROTECTIVE FILM PRIOR TO INSTALLING EACH FASCIA SECTION.



Customer Service  
 800-558-2162

DATE: 02/21/22  
 DRN BY: MLM  
 CKD BY: MM

SHT.# 3 OF 5  
 DWG# 18110-2085





# VERSITRIM 2000 EXTENDED CANTED FASCIA

GALVANIZED WATERDAM VERSION

INSTALLATION INSTRUCTIONS

## TYPICAL INSTALLATION

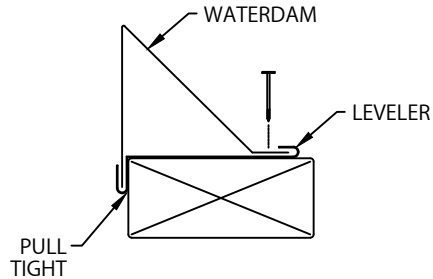
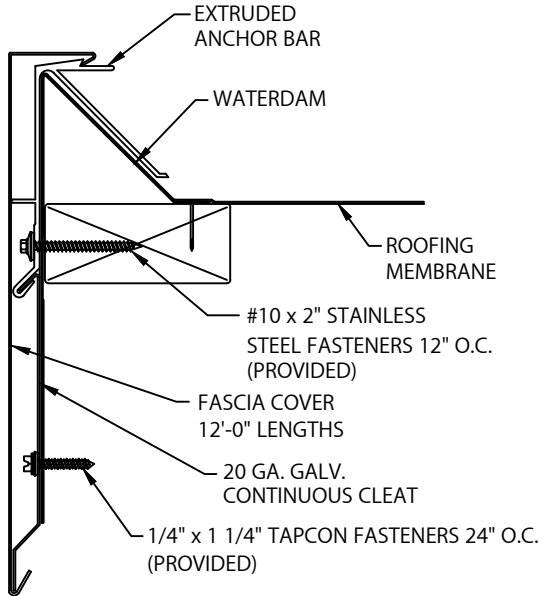

WATERDAM MUST BE PULLED TIGHT TO THE OUTSIDE FACE OF THE BUILDING BEFORE NAILING THE ROOF FLANGE.

U.S. Patent # 7,451,572



Customer Service  
800-558-2162

DATE: 02/21/22
DRN BY: MLM
CKD BY: MM

SHT.# 4 OF 5

DWG# 18110-2085

M



# VERSITRIM 2000 EXTENDED CANTED FASCIA

GALVANIZED WATERDAM VERSION

INSTALLATION INSTRUCTIONS

## COMPONENT LIST

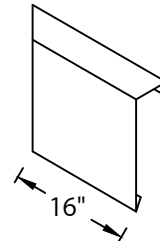
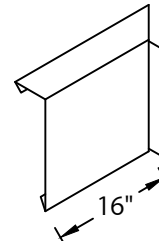
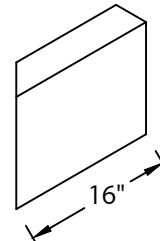
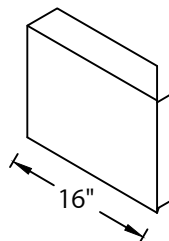
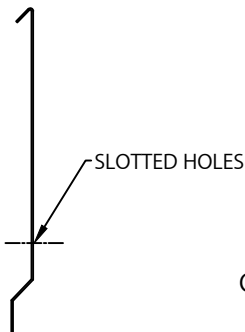
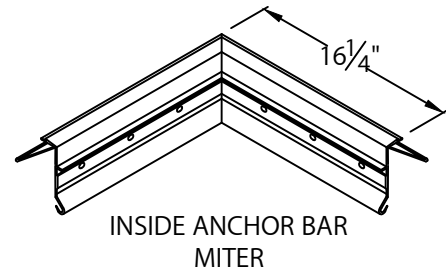
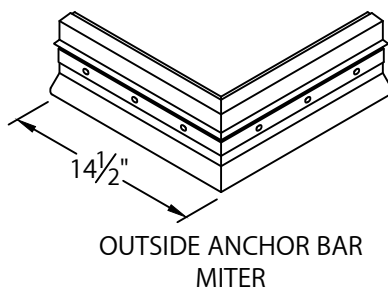
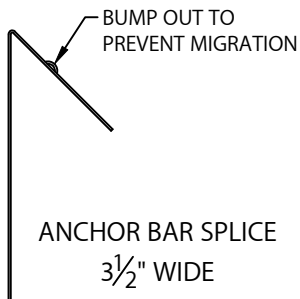
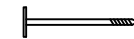
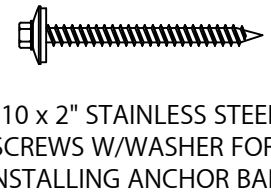
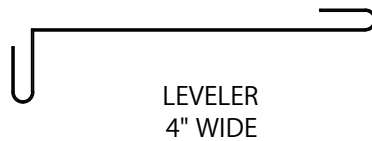
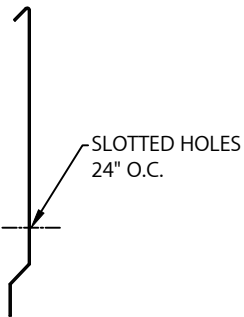
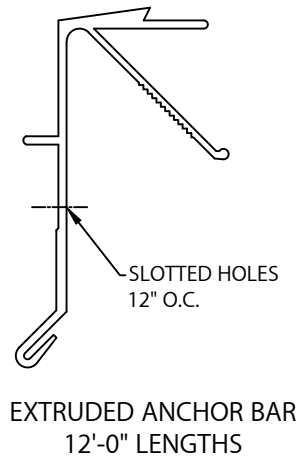
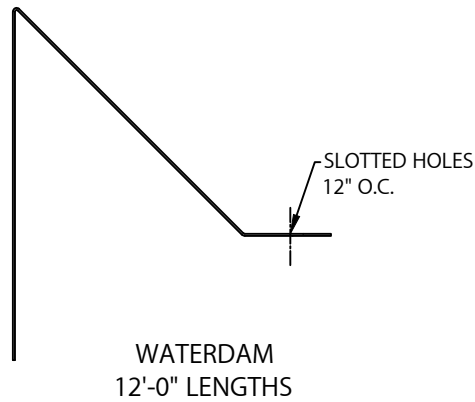
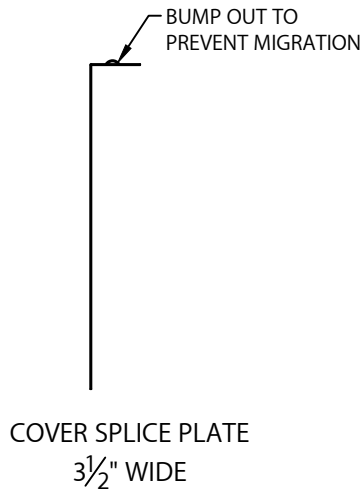
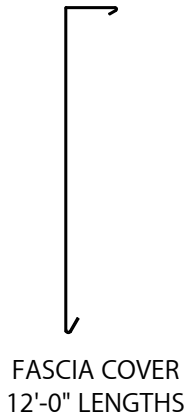

Customer Service  
800-558-2162

DATE: 02/21/22  
DRN BY: MLM  
CKD BY: MM

SHT.# 5 OF 5

DWG# 18110-2085

M