



# ELEVATE SYSTEM 300 RADIUS FASCIA

BUILT-UP OR MODIFIED APPLICATION, SNAP-ON VERSION

**IMPORTANT!!!** MUST INDICATE PROPER RADIUS CONDITION BY CIRCLING APPROPRIATE OUTSIDE FACE

**PROVIDING A RADIUS**

THE RADIUS MAY BE PROVIDED IN ONE OF TWO METHODS:

1.) THE ACTUAL KNOWN RADIUS IS

\_\_\_\_\_ ' FEET \_\_\_\_\_ " INCHES

MINIMUM OF 13'-0" (CALL IF LESS)

OR

2.) FIELD CONDITION MEASUREMENTS

NOTE: REFER TO ATTACHED WORKSHEET FOR FURTHER INFORMATION

\_\_\_\_\_ " INCHES

RISE

MAXIMUM OF 1 1/32" (CALL IF MORE)

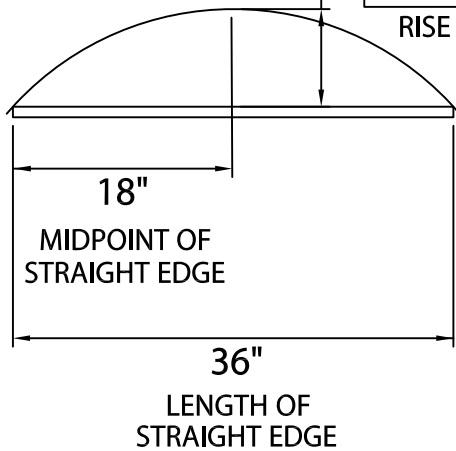

NOTE: CHECK MEASUREMENTS ALONG ENTIRE RADIUS.

DETAIL A

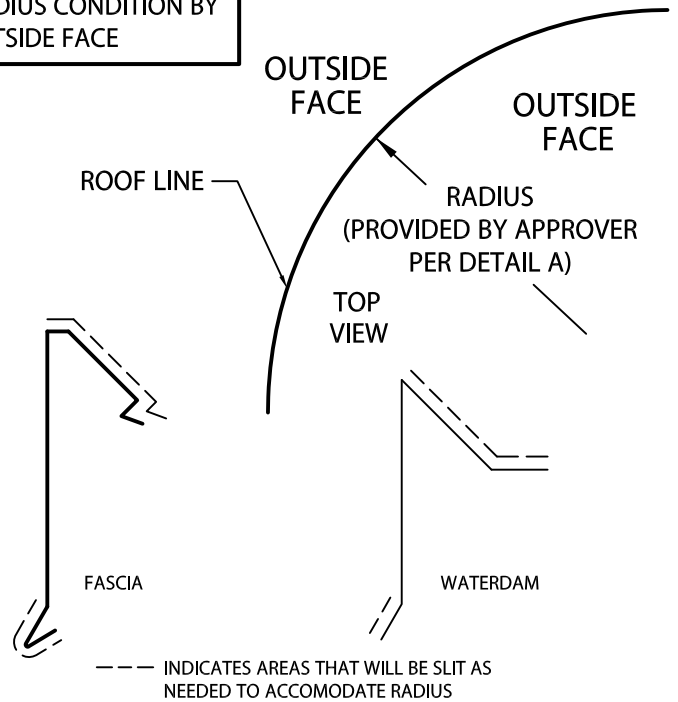

**FIRESTONE SYSTEM 300 DIMENSIONS**

PRODUCT ID. NO.	H DIM	X DIM	NAILER COVERAGE
<input type="checkbox"/> FA-350	5 1/4"	2 7/8"	1 NAILER
<input type="checkbox"/> FA-365	6 3/4"	4 3/8"	2 NAILERS
<input type="checkbox"/> FA-380	8 1/4"	5 7/8"	3 NAILERS
<input type="checkbox"/> FA-395	9 3/4"	7 3/8"	4 NAILERS
<input type="checkbox"/> FA-3110	11 1/4"	8 7/8"	5 NAILERS
<input type="checkbox"/> FA-3125	12 3/4"	10 3/8"	6 NAILERS

Fabrication will proceed only after receipt of signed print approval.

## Print Approval:

Architect and/or contractor shall verify all dimensions, sizes and quantities. All products to be installed in strict accordance with Elevate's printed instructions.

Approved by: \_\_\_\_\_

Date: \_\_\_\_\_

**MATERIAL:**

\*OIL CANNING CAN OCCUR ON LARGER FACE HEIGHTS. RECOMMEND .050" OR .063" FOR FACE HEIGHTS ABOVE 8 1/4"

\_\_\_ 24 GA. GALV. STEEL\*

\_\_\_ .040" ALUMINUM\*

\_\_\_ .050" ALUMINUM

\_\_\_ .063" ALUMINUM

\_\_\_ OTHER \_\_\_\_\_

COLOR: \_\_\_\_\_

FINISH: \_\_\_\_\_

**QUANTITIES:**

\_\_\_\_\_ LINEAL FEET 12'-0" LENGTHS

PROJECT:

ARCHITECT:

ROOFING CONTRACTOR:

REPRESENTATIVE/DISTRIBUTOR:



ELEVATE  
26 CENTURY BLVD.  
SUITE 205  
NASHVILLE, TN 37214  
CONTACT YOUR LOCAL ELEVATE REPRESENTATIVE

DATE: 03/16/23

DRN BY: MLM

CKD BY: MM

SHT.# \_\_\_\_\_ OF \_\_\_\_\_

DWG# 13010-15614

D