

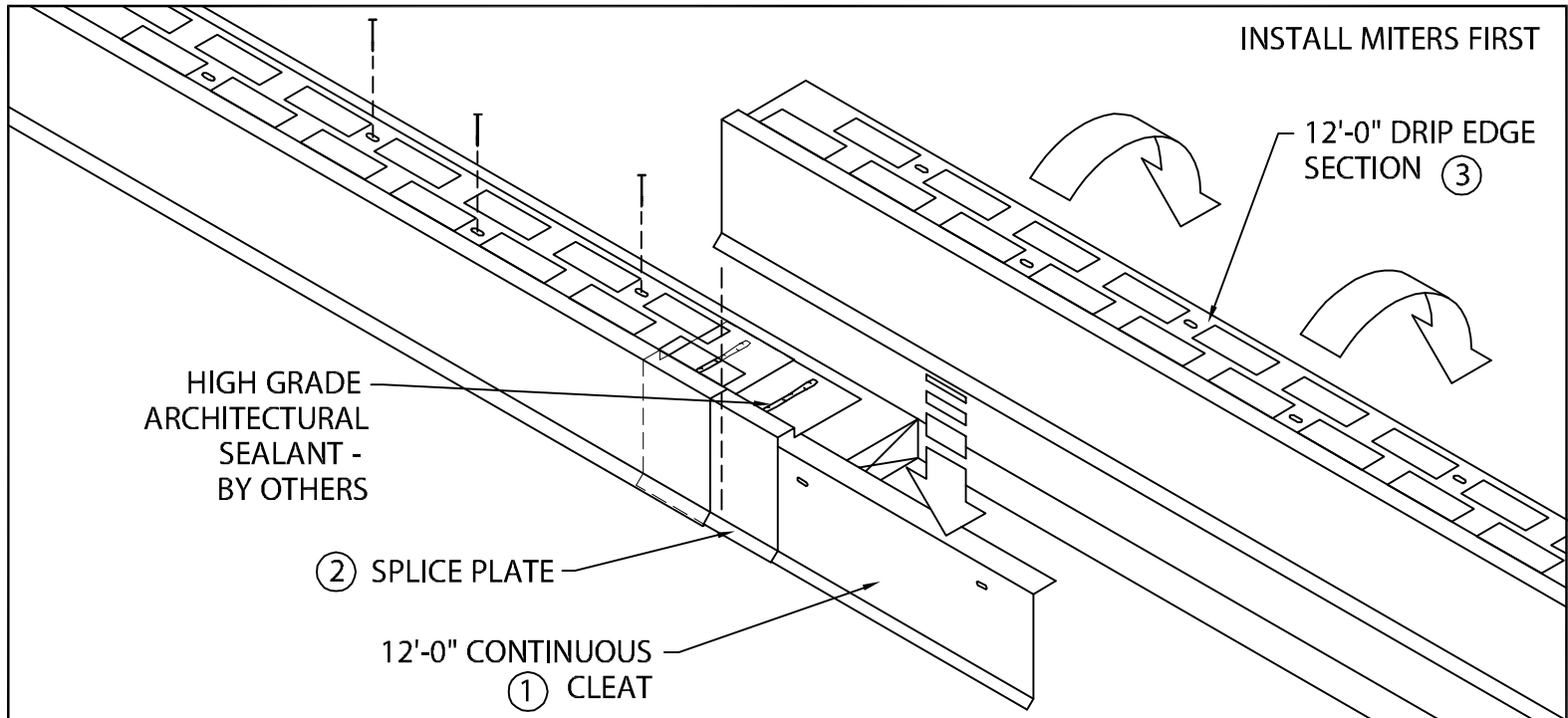

ONE FLASH-THRU DRIP EDGE

BUILT-UP OR MODIFIED VERSION

INSTALLATION INSTRUCTIONS



STEP ① - POSITION AND FASTEN CONTINUOUS CLEAT 12" O.C. AS SHOWN WITH APPROPRIATE FASTENERS.

STEP ② - LOCATE AND FASTEN 6" WIDE SPLICE PLATES AT EACH JOINT. SEALANT (BY OTHERS) TO BE FIELD APPLIED TO TOP OF EACH SPLICE PLATE AS SHOWN.

STEP ③ - HOOK DRIP EDGE OF EACH DRIP EDGE SECTION ONTO CONTINUOUS CLEAT, ROTATE INTO PLACE, AND FASTEN WITH APPROPRIATE FASTENERS.

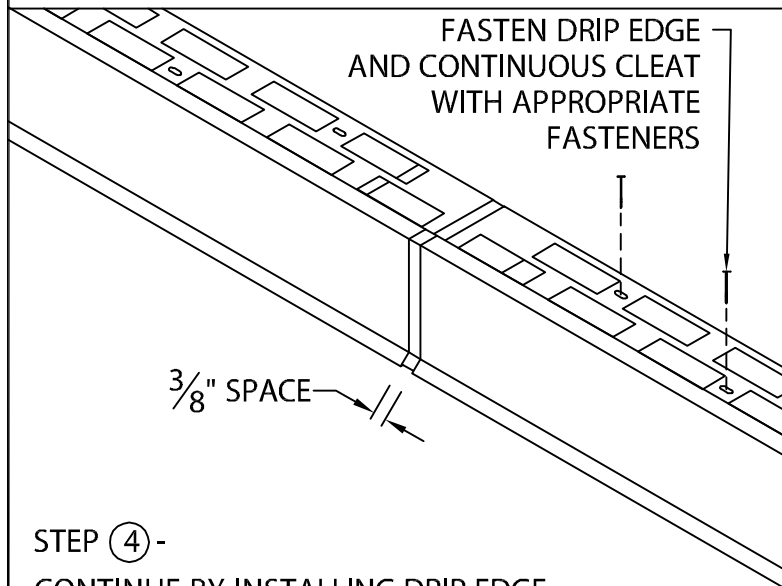

STEP ④ - CONTINUE BY INSTALLING DRIP EDGE SECTIONS ALLOWING A 3/8" SPACE BETWEEN SECTIONS AS SHOWN. FIELD CUT AS NECESSARY. REMOVE PROTECTIVE FILM IMMEDIATELY AFTER INSTALLATION. INSTALLERS SHALL WEAR PROTECTIVE EYEWEAR TO PREVENT INJURY.

TYPICAL INSTALLATION

