



ELEVATE EXPANSION JOINT

ROOF TO ROOF

NOTES

- Unless otherwise noted, fabrication of miters and accessories are furnished standard utilizing a non-penetrating quicklock joint, then factory sealed watertight
- Welded accessories require a minimum material thickness of .050"
- For non-90 miters, see separate print approval
- Product should be installed per provided installation instructions

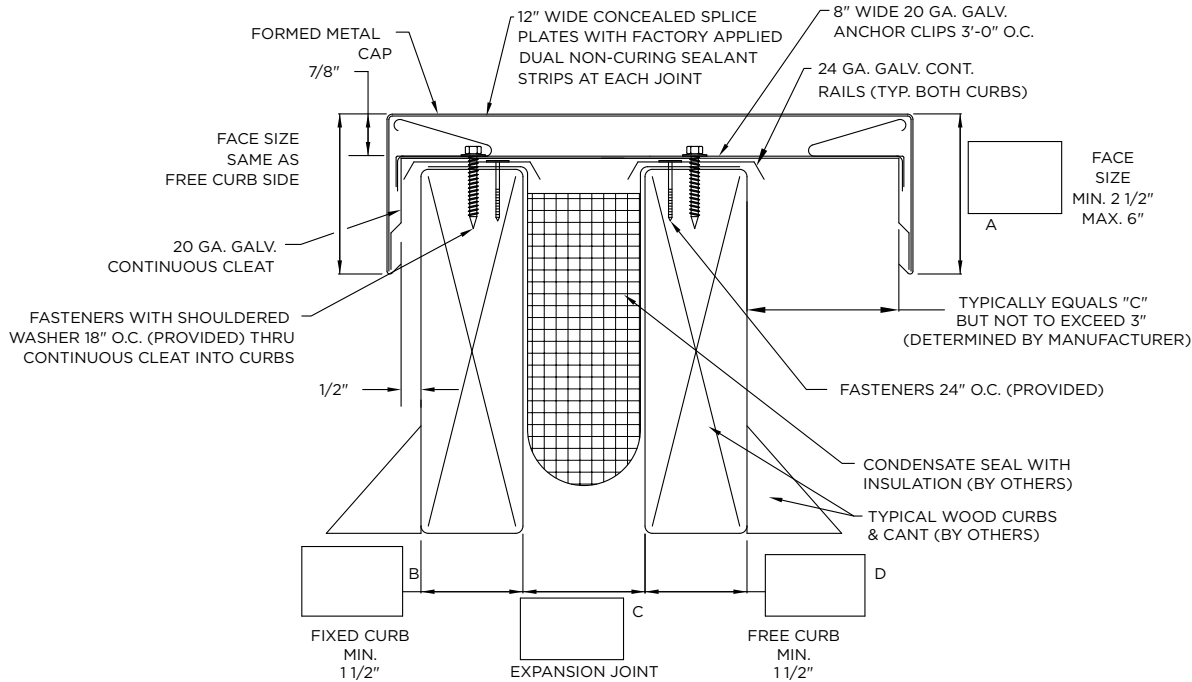

DIMENSIONS

PLEASE FILL OUT DIMENSIONS ON DRAWING

MATERIAL

- 24 Ga. Galv. Steel
- 22 Ga. Galv. Steel
- .040" Aluminum
- .050" Aluminum
- .063" Aluminum
- OTHER: _____

Color: _____

Finish: _____

Substrate:

If substrate is not given, wood fasteners will be provided.

- Wood
- Masonry
- Metal

PROJECT INFO

Project Name: _____

Architect: _____

Roofing Contractor: _____

Project Type:

By selecting this box you have verified and confirmed that dimensions, sizes, and quantities are correct. All products will be installed in strict accordance with printed instructions.

Date: _____

SHT# 1 of 1

DATE: 04/07/23

DRN BY: JJC

CKD BY: MM

DWG #: 13028-11972

REV: G

QUANTITIES

_____ Lineal Feet (12'-0" Lengths)

_____ Outside Miters (90°)

_____ Inside Miters (90°)

_____ Endcaps Inserts

_____ Endwall Flashings (.040" Mill Painted/Welded Only)

Accessory Type: Quicklock (Default) Welded (Surcharge)

Elevate
26 Century Blvd.
Suite 205
Nashville, TN 37214
Contact your local
Elevate representative.