



PRESTO-TITE RADIUS EDGE ONE

FULLY ADHERED OR MECHANICALLY ATTACHED SINGLE-PLY VERSION

24 GA. AND .040" ALUMINUM COVER MATERIAL

IMPORTANT!!! MUST INDICATE PROPER RADIUS CONDITION BY CIRCLING APPROPRIATE OUTSIDE FACE

PROVIDING A RADIUS
THE RADIUS MAY BE PROVIDED IN ONE OF TWO METHODS:

1.) THE ACTUAL KNOWN RADIUS IS



OR

2.) FIELD CONDITION MEASUREMENTS

NOTE: REFER TO ATTACHED WORKSHEET FOR FURTHER INFORMATION

(MAX. RISE ALLOWED IS 3 1/2" ON 36" CHORD)

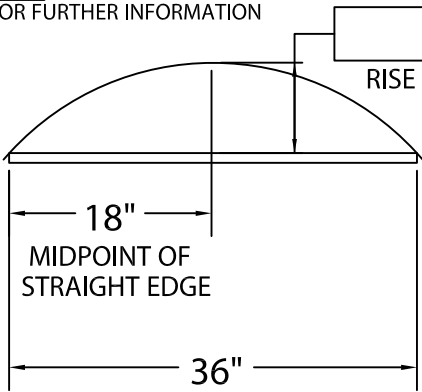

LENGTH OF STRAIGHT EDGE

NOTE: CHECK MEASUREMENTS ALONG ENTIRE RADIUS.

DETAIL A

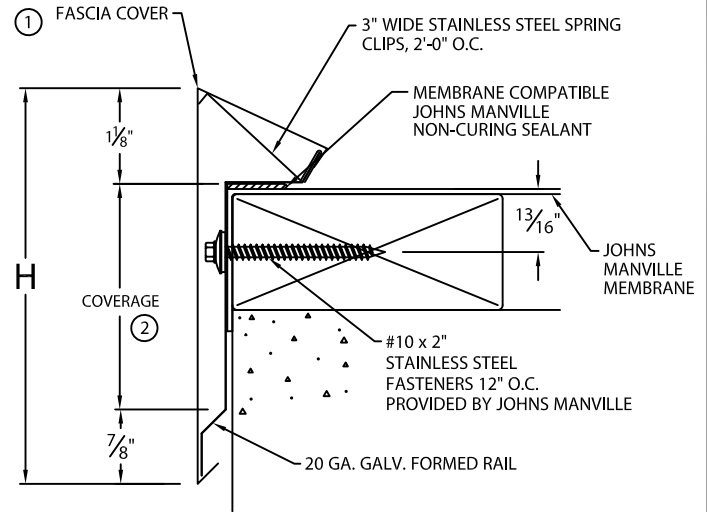
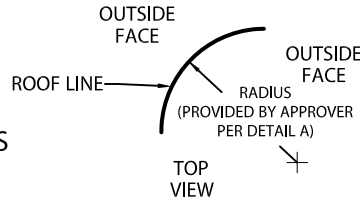

----- INDICATES AREA TO BE SLIT TO FORM RADIUS
 OVER 150'-0" RADIUS = NO SLITS
 30'-0" - 150'-0" RADIUS = SLITS 12" O.C.
 16'-0" - 30'-0" RADIUS = SLITS 6" O.C.
 8'-0" - 16'-0" RADIUS = SLITS 3" O.C.
 4'-0" - 8'-0" RADIUS = CUSTOM SLITS 3" O.C.

NOTES:

- ① FASCIA COVER PROVIDED WITH 1" LAP JOINT
- ② TYPICALLY COVERAGE SHOULD EXTEND A MIN. OF 1" BELOW WOOD BLOCKING IF APPLICABLE.

FASCIA DIMENSIONS

PRODUCT ID. NO.	H DIM	COVERAGE
<input type="checkbox"/> ESE-S40	4"	2"
<input type="checkbox"/> ESE-S50	5"	3"
<input type="checkbox"/> ESE-S65	6 1/2"	4 1/2"
<input type="checkbox"/> ESE-S80	8"	6"

Fabrication will proceed only after receipt of signed print approval.

Print Approval:

Architect and/or contractor shall verify all dimensions, sizes and quantities. All products to be installed in strict accordance Johns Manville's printed instructions.

Approved by: _____

Date: _____

MATERIAL:

- ___ 24 Ga. Galv. Steel
- ___ .040" Aluminum
- ___ OTHER _____

Color: _____

Finish: _____

QUANTITIES:

_____ Lineal Feet 12'-0" Lengths
 Cover and Rail Supplied in 12'-0" Lengths for 16'-0" radius or greater.
 Cover and Rail Supplied in 6'-0" Lengths for radius less than 16'-0".

PROJECT:

ARCHITECT:

ROOFING CONTRACTOR:

REPRESENTATIVE/DISTRIBUTOR:

51 Lexington Street; Lewiston, ME 04240
 CUSTOMER SERVICE: 800-223-8317 USA
 800-445-1500 Canada
 TECHNICAL SERVICE: 800-445-1500 USA & Canada
 FAX: 207-784-0125
 OTHER AREAS CALL: 207-784-0123



DATE: 10/26/18

DRN BY: JJC

CKD BY: SAK

SHT.# ___ OF ___

DWG# 16010-20002 |