

ANCHOR CLIP DETAIL

**NOTES:**

- ① FACE = COVERAGE (SHOULD EXTEND A MIN. OF 1" BELOW WATERPROOFING MEMBRANE) + 1 7/8".
- ② 24 GA. GALV. AND .040" ALUM. COPING COVERS AVAILABLE FOR WALL SIZES 8" TO 24" ONLY.
- ③ WELDED ACCESSORIES REQUIRE A MINIMUM MATERIAL THICKNESS OF .050".
- ④ FOR NON 90° MITERS PLEASE USE PRINT APPROVAL #11011-1487.

**AUTHORIZED SIGNATURE:**

APPROVED BY: \_\_\_\_\_

DATE: \_\_\_\_\_

**ANSI/SPRI ES-1 TESTED**

U.S. PATENT # 8,978,317 B1

**MATERIAL:**

- \_\_\_ 24 GA. GALVANIZED STEEL ②
  - \_\_\_ 22 GA. GALVANIZED STEEL
  - \_\_\_ .040" ALUMINUM ②
  - \_\_\_ .050" ALUMINUM
  - \_\_\_ .063" ALUMINUM
  - \_\_\_ OTHER \_\_\_\_\_
- COLOR: \_\_\_\_\_
- FINISH: \_\_\_\_\_

**QUANTITIES:**

\_\_\_\_\_ LINEAL FEET 12'-0" LENGTHS

**ACCESSORIES:**

- \_\_\_ OUTSIDE MITERS @ 90° ④
- \_\_\_ INSIDE MITERS @ 90° ④
- \_\_\_ RIGHT ENDCAPS
- \_\_\_ LEFT ENDCAPS

SPECIFY ACCESSORY TYPE:

- WELDED ③
- QUICKLOCK

ENDWALL FLASHING (SPlice PLATE VERSION)

RIGHT HAND \_\_\_\_\_ LEFT HAND \_\_\_\_\_

ENDWALL FLASHING (COPING VERSION)

RIGHT HAND \_\_\_\_\_ LEFT HAND \_\_\_\_\_

PROJECT:

ARCHITECT:

ROOFING CONTRACTOR:

REPRESENTATIVE/DISTRIBUTOR:

CORPORATE OFFICES, MANUFACTURING  
1600 AIRPORT ROAD; WAUKESHA, WI 53188

PHONE: 800-558-2162  
FAX: 800-373-9156

WEBSITE: WWW.METALERA.COM  
EMAIL: QUOTE@METALERA.COM

DATE: 04/10/17

DRN BY: JJC

CKD BY: SAK

SHT.# \_\_\_\_\_ OF \_\_\_\_\_

DWG# 11011-21037

C

PERMA-TITE GOLD CANTILEVER COPING  
STANDARD ACCESSORIES

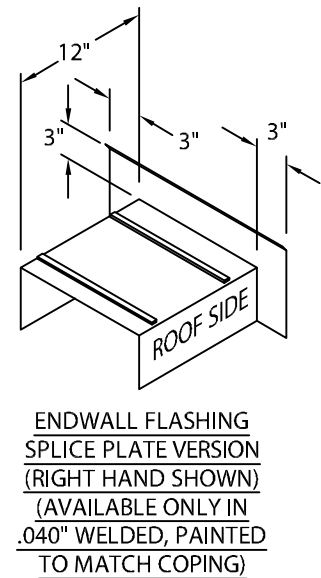
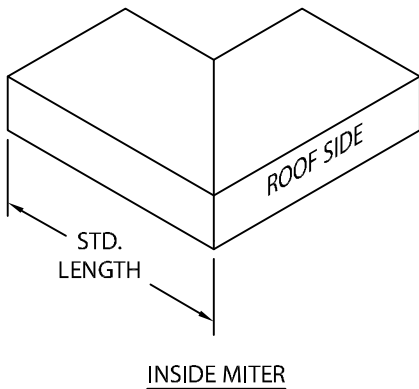
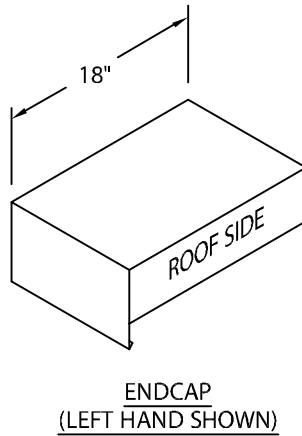
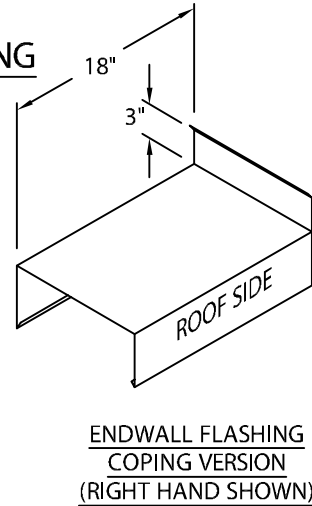
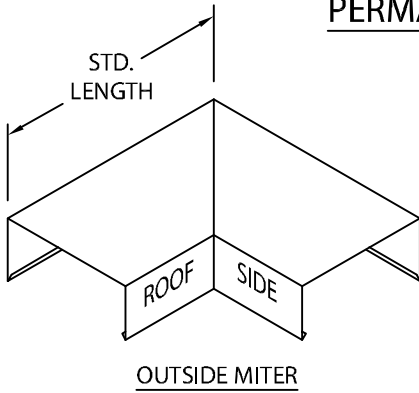

MITER STANDARD LEG LENGTH:  
WALL SIZE + 9<sup>5</sup>/<sub>8</sub>" = LENGTH

**ADDITIONAL ACCESSORIES ARE AVAILABLE ON WEBSITE:**

- TRANSITION MITERS
- STRAIGHT TRANSITION MITERS
- "T" MITERS
- "Z" MITERS
- STEP-UP MITERS
- PEAK / VALLEY MITERS
- PILASTER CAPS
- RADIUS COPING
- ARCHED COPING

(FOR ADDITIONAL ACCESSORY REQUIREMENTS, ATTACH SKETCHES OR CALL MANUFACTURER FOR ASSISTANCE).