



PERMA-TITE QUICKLOCK RADIUS COPING

EXISTING SLOPE VERSION

IMPORTANT!!! MUST INDICATE PROPER RADIUS CONDITION BY CIRCLING APPROPRIATE OUTSIDE FACE

PROVIDING A RADIUS
THE RADIUS MAY BE PROVIDED
IN ONE OF TWO METHODS:

1.) THE ACTUAL KNOWN RADIUS IS

_____ ' FEET _____ " INCHES

MINIMUM
OF 3'-0"

OR

2.) FIELD CONDITION MEASUREMENTS

NOTE: REFER TO ATTACHED WORKSHEET
FOR FURTHER INFORMATION

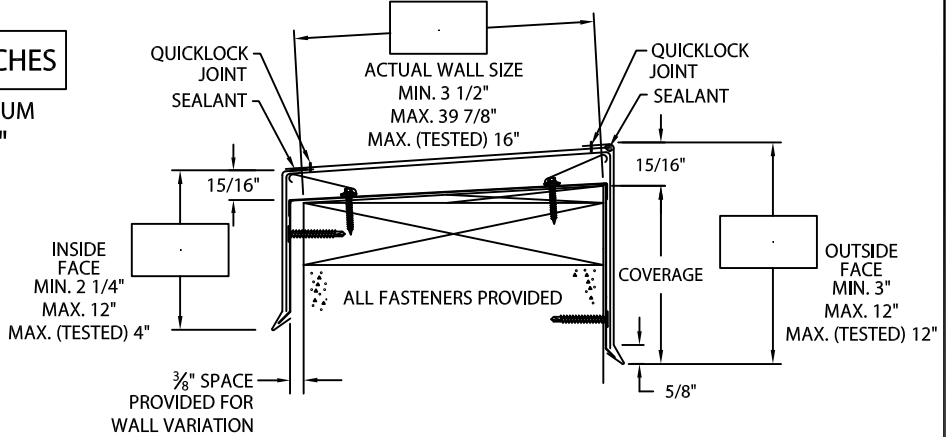
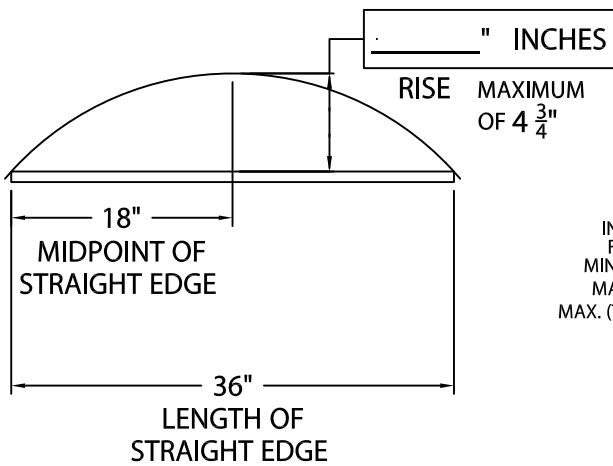
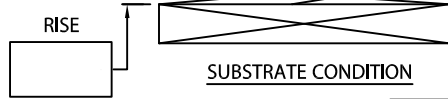
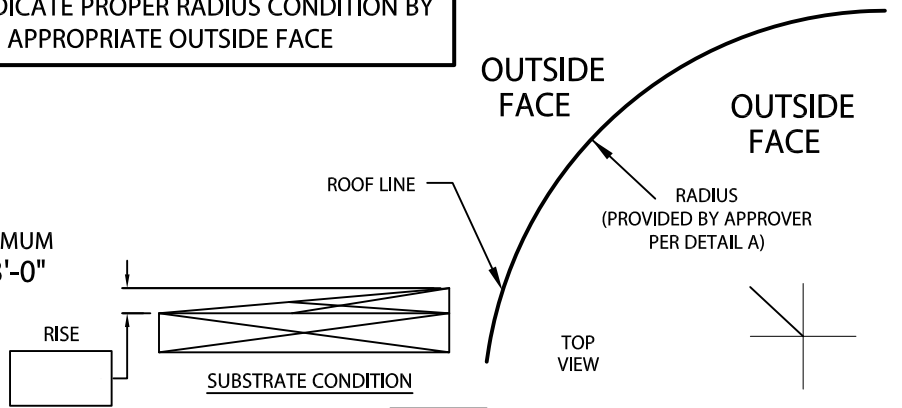

NOTE: CHECK MEASUREMENTS ALONG ENTIRE RADIUS.

DETAIL A

PLEASE SPECIFY SUBSTRATE:
(IF SUBSTRATE INFORMATION IS NOT GIVEN, WOOD SUBSTRATE FASTENERS WILL BE PROVIDED)

WOOD
 MASONRY
 METAL

NOTES: -- CONCEALED SPLICE PLATES ARE PROVIDED WITH FACTORY APPLIED DUAL NON-CURING SEALANT STRIPS.
-- FABRICATION OF RADIUS IS FURNISHED UTILIZING A NON-PENETRATING QUICKLOCK JOINT, THEN FACTORY SEALED WATERTIGHT.

MATERIAL:

___ 24 GA. STEEL ___ .050" ALUMINUM
___ .040" ALUMINUM ___ .063" ALUMINUM
___ OTHER _____
COLOR: _____
FINISH: _____

QUANTITIES:

_____ LINEAL FEET 4'-0" LENGTHS

Fabrication will proceed only after receipt of signed print approval.

Print Approval:

Architect and/or contractor shall verify all dimensions, sizes and quantities. All products to be installed in strict accordance with Metal-Era's printed instructions.

Approved by: _____

Date: _____

PROJECT:

ARCHITECT:

ROOFING CONTRACTOR:

REPRESENTATIVE/DISTRIBUTOR:

Corporate Offices, Manufacturing
1600 Airport Road; Waukesha, WI 53188
Phone: 800-558-2162
Fax: 800-373-9156
www.metalera.com



DATE: 03/20/23

SHT.# ___ OF ___

DRN BY: MLM

CKD BY: MM

DWG# 11011-37518

C