

SEAL-TITE INDUSTRIAL GUTTER WITH ELIMINAILER™ T

IG-B VERSION

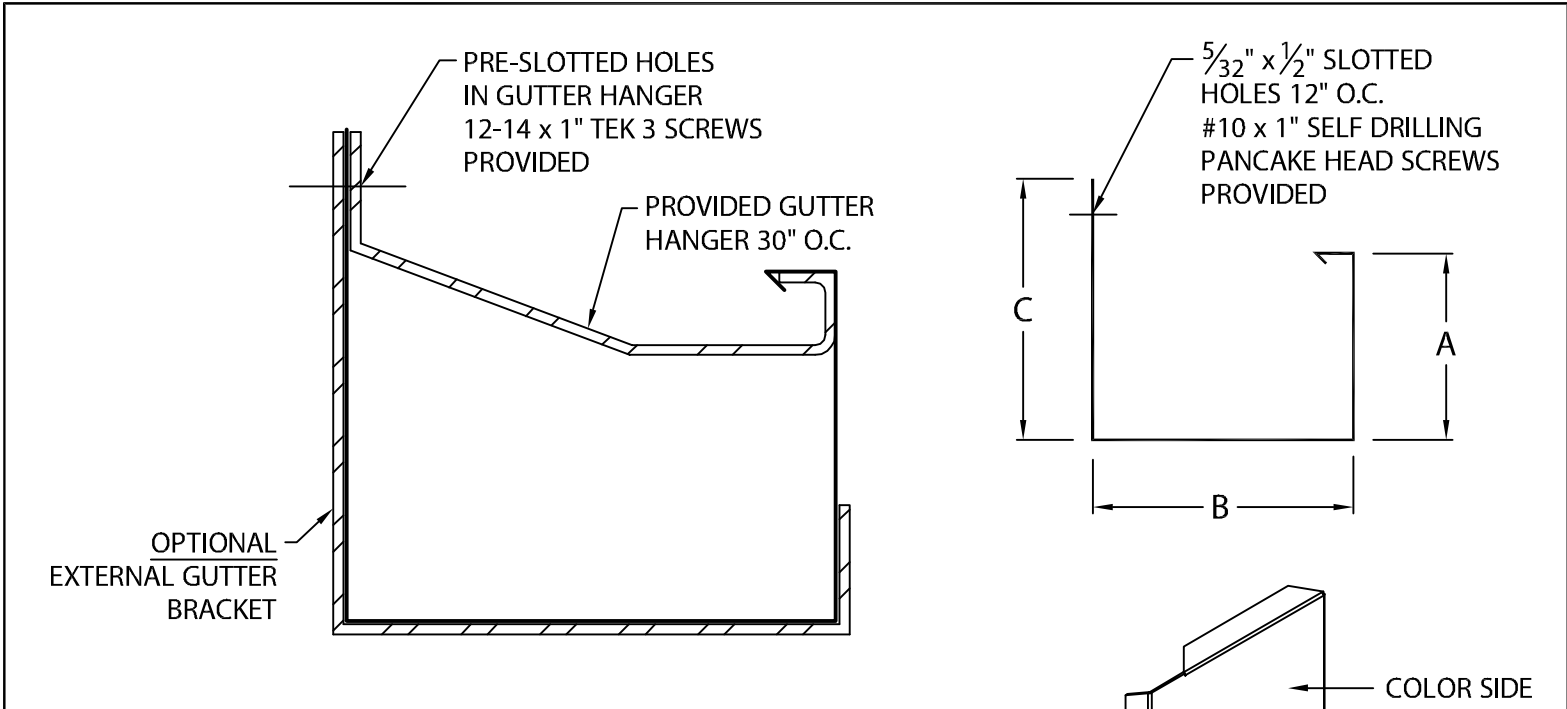

PRODUCT ID #	C	B	A	HANGER
<input type="checkbox"/> IGB-C6	6"	4 1/8"	4 1/2"	1 1/4" X .100 Mill
<input type="checkbox"/> IGB-C7	7"	6"	6"	1 1/4" X .100 Mill
<input type="checkbox"/> IGB-C8	8"	7"	7"	2" X .100 Mill
<input type="checkbox"/> IGB-C9	9"	8"	8"	2" X .100 Mill

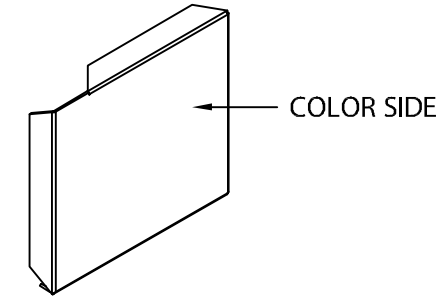
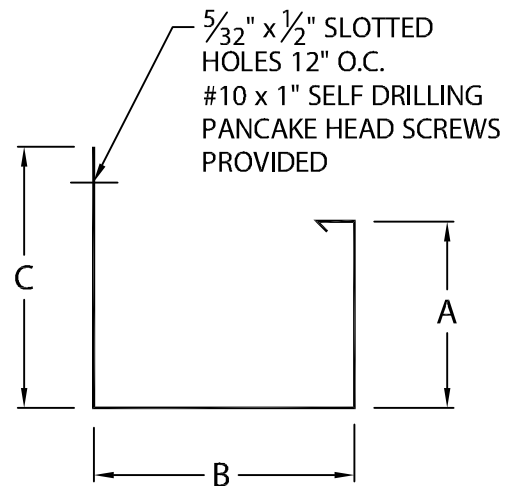

NOTES:
 -- MAXIMUM DOWNSPOUT DIMENSION NOT TO EXCEED "B2" MINUS 9/16".
 -- 2" LAP JOINTS PROVIDED.
 -- 1/8" STAINLESS STEEL POP RIVETS PROVIDED.
 -- UNLESS OTHERWISE NOTED, FABRICATION OF MITERS ARE FURNISHED STANDARD UTILIZING A NON-PENETRATING QUICKLOCK JOINT, THEN FACTORY SEALED WATERTIGHT.
 -- WELDED ACCESSORIES REQUIRE A MINIMUM MATERIAL THICKNESS OF .050".

MATERIAL:
 ___ 24 GA. GALVANIZED STEEL
 ___ .040" ALUMIINIUM COLOR: _____
 ___ .050" ALUMINIUM FINISH: _____
 ___ .063" ALUMINIUM
 ___ OTHER _____

Fabrication will proceed only after receipt of signed print approval.
Print Approval:
 Architect and/or contractor shall verify all dimensions, sizes and quantities. All products to be installed in strict accordance with Metal-Era's printed instructions.
 Approved by: _____
 Date: _____

QUANTITIES:
 _____ LINEAL FEET 12'-0" LENGTHS
 _____ OUTSIDE MITERS @ 90°
 _____ INSIDE MITERS @ 90°
 _____ RIGHT ENDCAPS
 _____ LEFT ENDCAPS
 _____ EXPANSION JOINTS STYLE "1"
 _____ EXPANSION JOINTS STYLE "2"
 SPECIFY MITER TYPE:
 WELDED
 QUICKLOCK
 FOR EXTERNAL GUTTER BRACKETS SEE PRINT APPROVAL #11012-1509
 FOR NON-90 MITERS SEE PRINT APPROVAL #11012-10010

PROJECT:
ARCHITECT:
ROOFING CONTRACTOR:
REPRESENTATIVE/DISTRIBUTOR:

Corporate Offices, Manufacturing
 1600 Airport Road; Waukesha, WI 53188
 Phone: 800-558-2162
 Fax: 800-373-9156
 www.metalera.com



DATE: 11/09/17
 DRN BY: JJC
 CKD BY: SAK
 SHT.# ____ OF ____
 DWG# 11012-27508 A