



# PRESTO-LOCK COPING

FLAT VERSION - 4'-0" O.C.

## INSTALLATION INSTRUCTIONS

**IMPORTANT:** Prior to installation, read instructions carefully.  
**NOTE:** Position roof membrane on top of the wall covering the treated wood nailer(s) or substrate completely. Allow 1/2" minimum excess membrane beyond nailer where applicable. NRCA requirement.

**CAUTION:** INSTALL MITERS FIRST!

### ANCHOR CLIP FASTENING DETAIL A OUTSIDE FACE HEIGHT 4" AND OVER

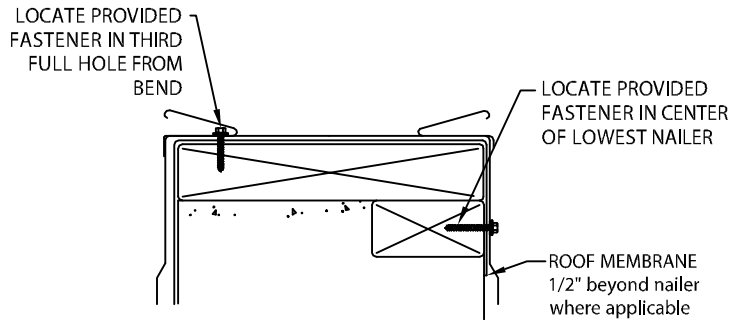

### ANCHOR CLIP FASTENING DETAIL B OUTSIDE FACE HEIGHT UNDER 4"

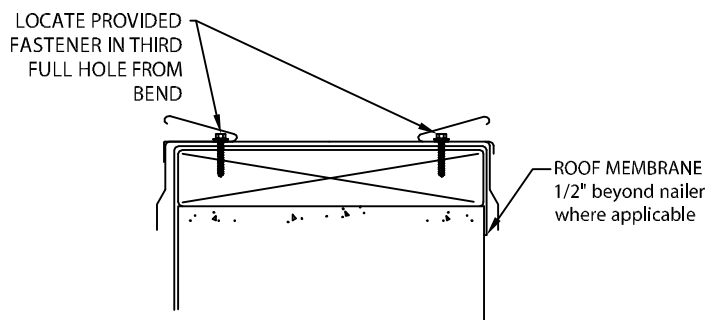

**NOTE:** THE FOLLOWING INSTALLATION INSTRUCTIONS REFLECT OUTSIDE FACE HEIGHTS OF 4" AND OVER.

### INSTALLATION NOTES:

1) Installing contractor shall check as-built conditions, including nailer attachment, and verify the manufacturer's coping details for accuracy to fit the wall assembly prior to fabrication.

2) Fasteners must be corrosion resistant and rated for a minimum 250# pullout force for the substrate that is being used.

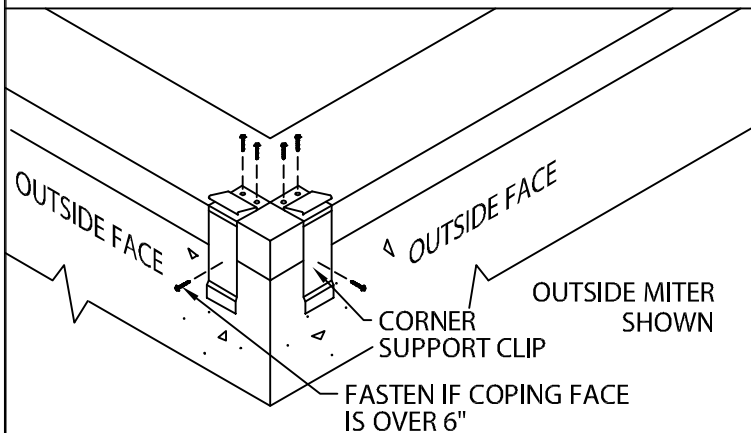
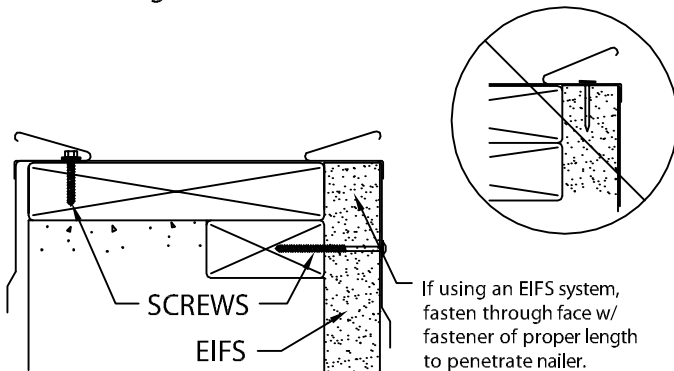

### STEP 1 - CORNER SUPPORT CLIPS

LOCATE AND FASTEN GALVANIZED CORNER SUPPORT CLIPS TO THE WALL. IF COPING FACE OVER 6", SECURE WITH ADDITIONAL FASTENER AS SHOWN.

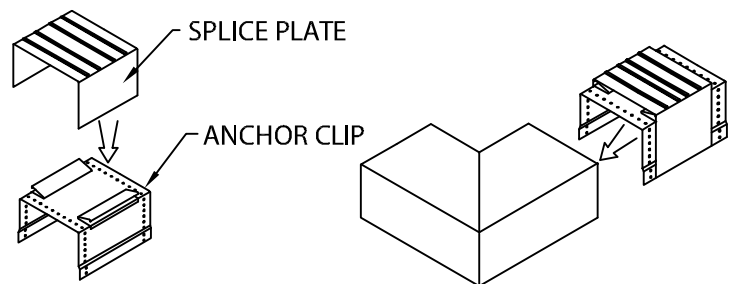

**STEP 2 - MITER SPLICE PLATES & ANCHOR CLIPS**  
 POSITION THE SPLICE PLATE IN THE CENTER OF THE ANCHOR CLIP. INSTALL THE SPLICE PLATE AND ANCHOR CLIP ASSEMBLY INTO EACH END OF THE CORNER AS SHOWN.



# PRESTO-LOCK COPING

FLAT VERSION - 4'-0" O.C.

## INSTALLATION INSTRUCTIONS

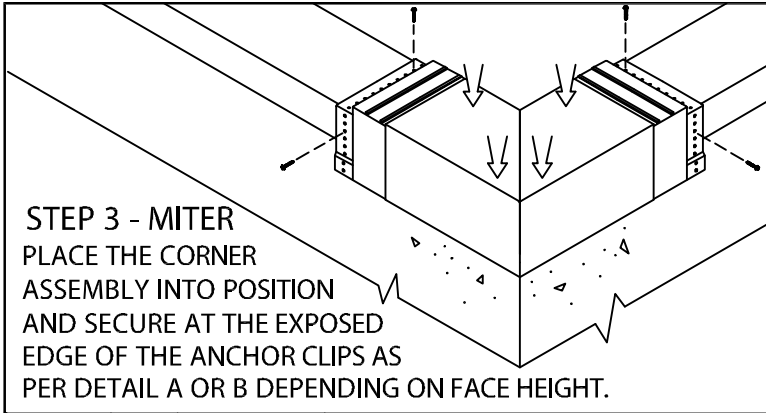

**STEP 3 - MITER**  
PLACE THE CORNER ASSEMBLY INTO POSITION AND SECURE AT THE EXPOSED EDGE OF THE ANCHOR CLIPS AS PER DETAIL A OR B DEPENDING ON FACE HEIGHT.

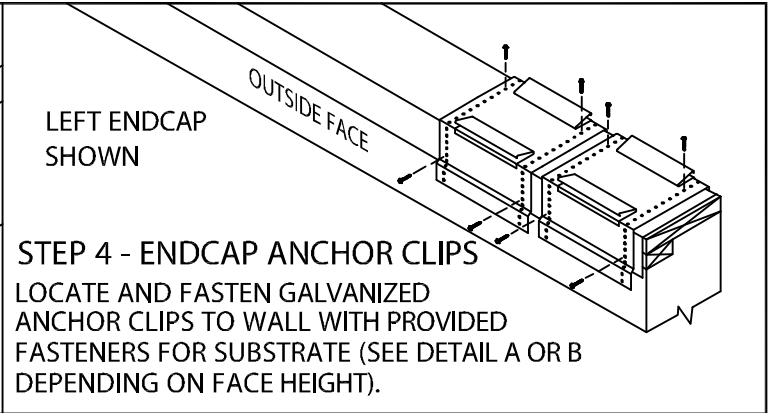

**STEP 4 - ENDCAP ANCHOR CLIPS**  
LOCATE AND FASTEN GALVANIZED ANCHOR CLIPS TO WALL WITH PROVIDED FASTENERS FOR SUBSTRATE (SEE DETAIL A OR B DEPENDING ON FACE HEIGHT).

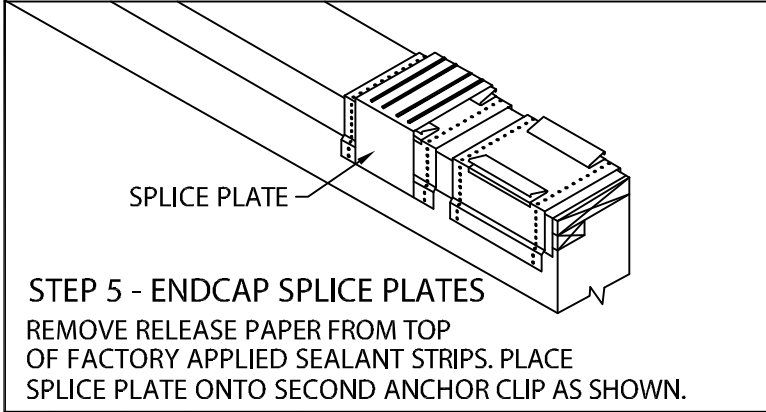

**STEP 5 - ENDCAP SPLICE PLATES**  
REMOVE RELEASE PAPER FROM TOP OF FACTORY APPLIED SEALANT STRIPS. PLACE SPLICE PLATE ONTO SECOND ANCHOR CLIP AS SHOWN.

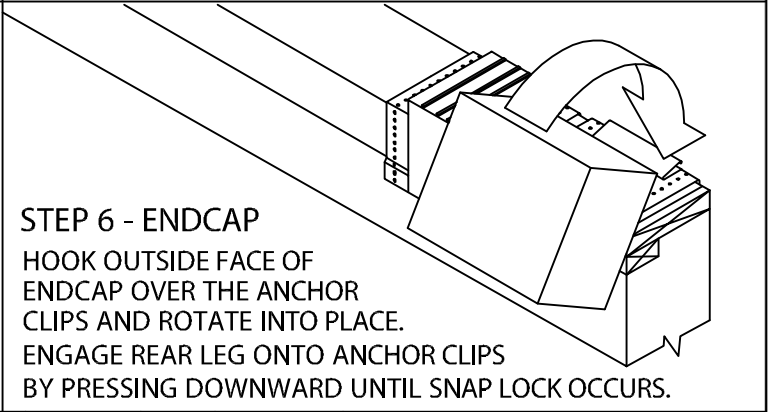

**STEP 6 - ENDCAP**  
HOOK OUTSIDE FACE OF ENDCAP OVER THE ANCHOR CLIPS AND ROTATE INTO PLACE. ENGAGE REAR LEG ONTO ANCHOR CLIPS BY PRESSING DOWNWARD UNTIL SNAP LOCK OCCURS.

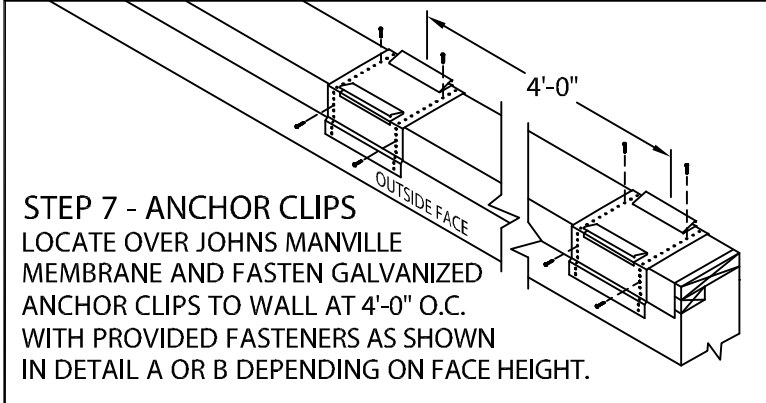

**STEP 7 - ANCHOR CLIPS**  
LOCATE OVER JOHNS MANVILLE MEMBRANE AND FASTEN GALVANIZED ANCHOR CLIPS TO WALL AT 4'-0" O.C. WITH PROVIDED FASTENERS AS SHOWN IN DETAIL A OR B DEPENDING ON FACE HEIGHT.

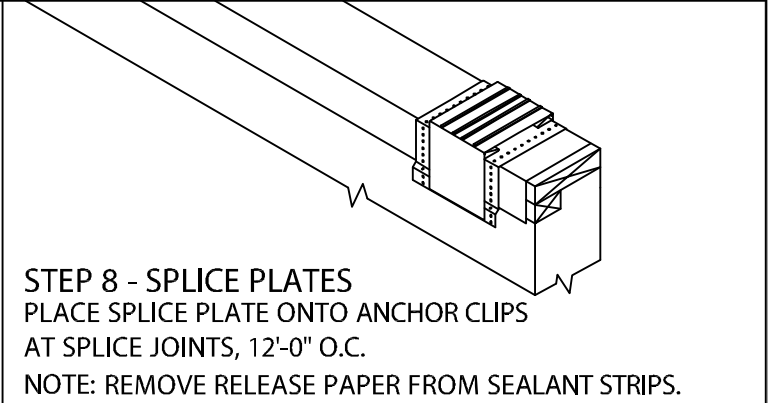

**STEP 8 - SPLICE PLATES**  
PLACE SPLICE PLATE ONTO ANCHOR CLIPS AT SPLICE JOINTS, 12'-0" O.C.  
NOTE: REMOVE RELEASE PAPER FROM SEALANT STRIPS.

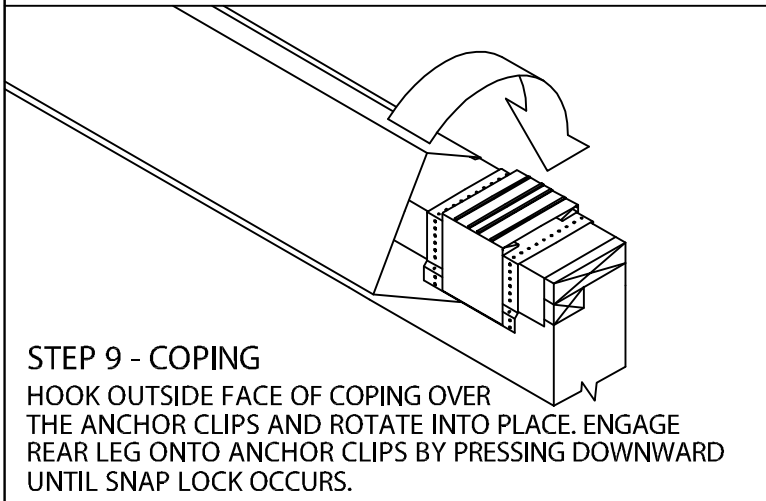

**STEP 9 - COPING**  
HOOK OUTSIDE FACE OF COPING OVER THE ANCHOR CLIPS AND ROTATE INTO PLACE. ENGAGE REAR LEG ONTO ANCHOR CLIPS BY PRESSING DOWNWARD UNTIL SNAP LOCK OCCURS.

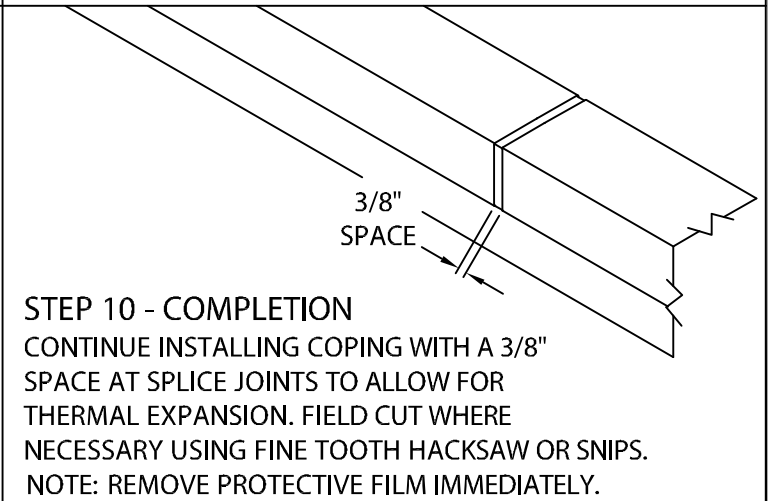

**STEP 10 - COMPLETION**  
CONTINUE INSTALLING COPING WITH A 3/8" SPACE AT SPLICE JOINTS TO ALLOW FOR THERMAL EXPANSION. FIELD CUT WHERE NECESSARY USING FINE TOOTH HACKSAW OR SNIPS.  
NOTE: REMOVE PROTECTIVE FILM IMMEDIATELY.



USA: 800-223-8317  
Canada: 800-445-1500

DATE: 10/26/16  
DRN BY: JJC  
CKD BY: SAK

SHT.# 2 OF 3  
DWG# 16111-25098 A

## TYPICAL COPING INSTALLATION (OUTSIDE FACE HEIGHT 4" AND OVER SHOWN)

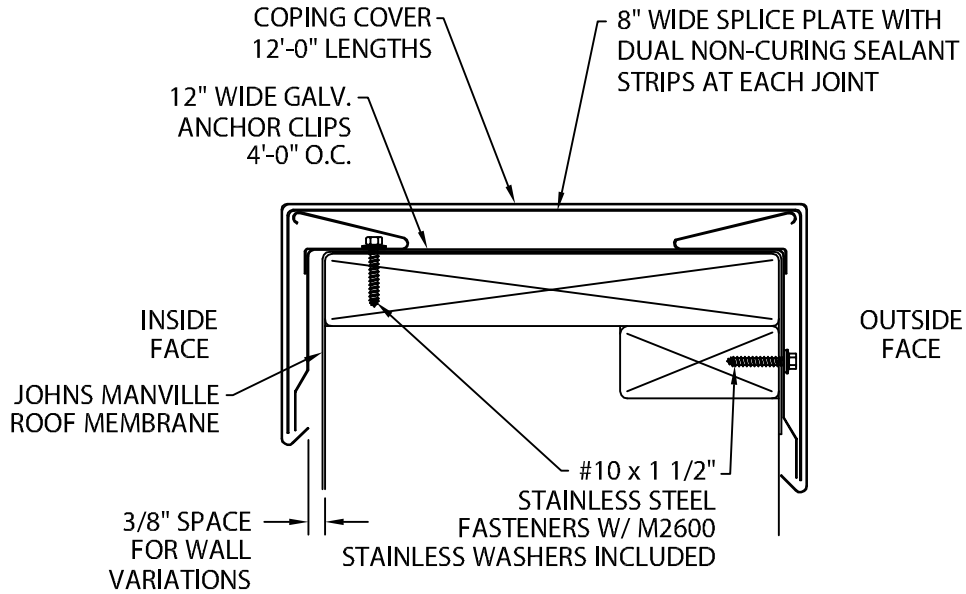

## TYPICAL COPING INSTALLATION (OUTSIDE FACE HEIGHT UNDER 4" SHOWN)

