

INDUSTRIAL DOWNSPOUT

CLOSED DOWNSPOUT, STYLE 1 DOWNSPOUT STRAP VERSION

INSTALLATION INSTRUCTIONS

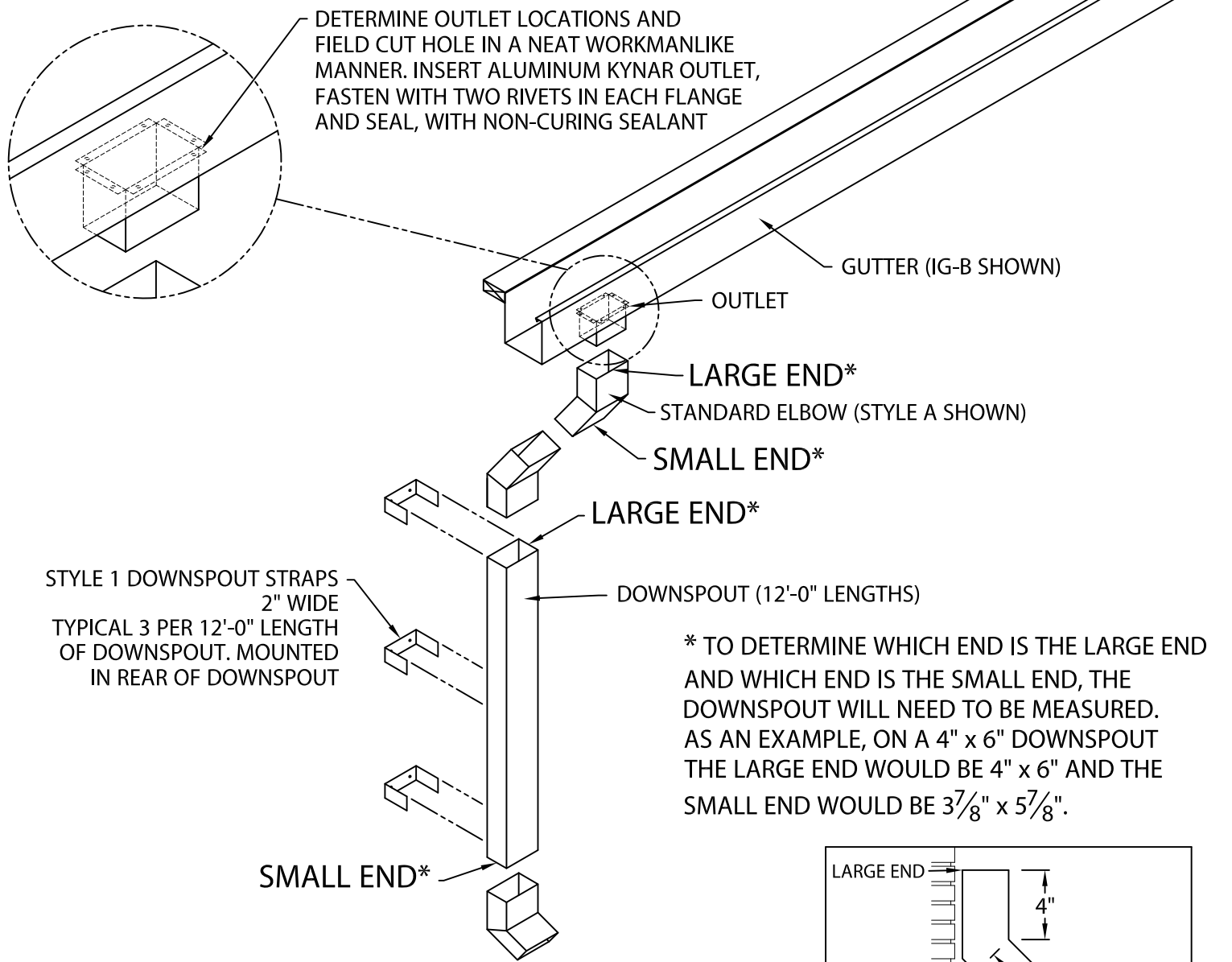

STYLE 1 DOWNSPOUT STRAPS
2" WIDE
TYPICAL 3 PER 12'-0" LENGTH
OF DOWNSPOUT. MOUNTED
IN REAR OF DOWNSPOUT

* TO DETERMINE WHICH END IS THE LARGE END AND WHICH END IS THE SMALL END, THE DOWNSPOUT WILL NEED TO BE MEASURED. AS AN EXAMPLE, ON A 4" x 6" DOWNSPOUT THE LARGE END WOULD BE 4" x 6" AND THE SMALL END WOULD BE 3⁷/₈" x 5⁷/₈".

DOWNSPOUT SECTION

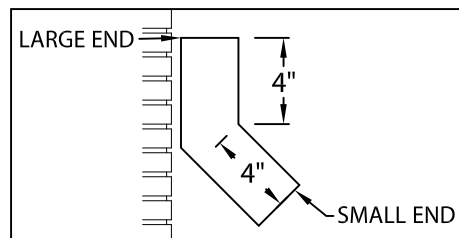
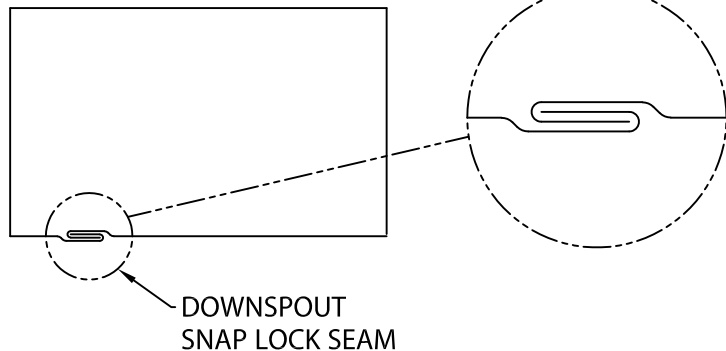

STYLE A DOWNSPOUT

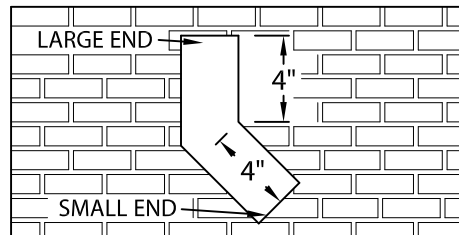

STYLE B DOWNSPOUT



Customer Service
866-458-3537
(Metal-Era)

DATE: 02/15/19
DRN BY: JJC
CKD BY: SAK

SHT.# ___ OF ___
DWG# 15113-30620

A