

DOW SYSTEM 200 FASCIA

CRIMP-ON VERSION

ANSI/SPRI ES-1 DESIGN PRESSURE OF 150 psf

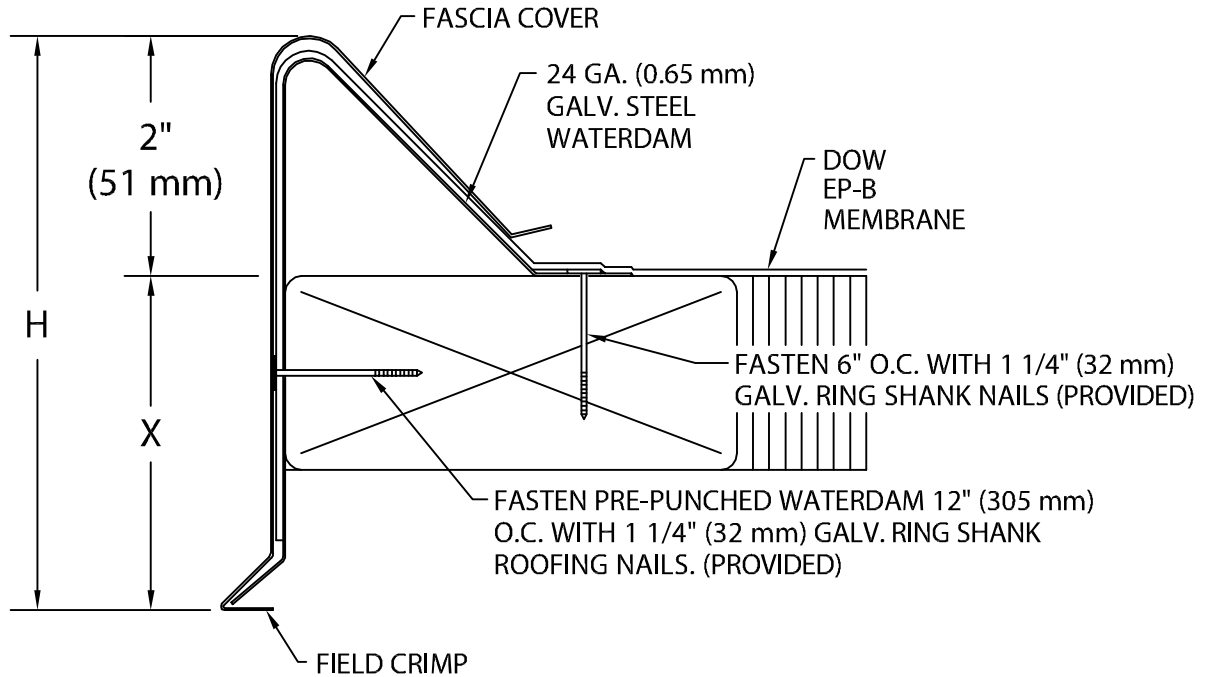

Fascia is to be installed per Specifications and Dow Roofing Systems' Installation Instructions Dwg. # 12110-2985

NOTE: FASCIA INCLUDES 3 1/2" (89 mm) WIDE SPLICE PLATE AT JOINTS.

MATERIAL:

- ___ 24 Ga. (.65 mm) Galv. Steel
- ___ .040" (1.01 mm) Aluminum
- ___ OTHER _____

Color: _____

Finish: _____

DOW SYSTEM 200 FASCIA DIMENSIONS

PRODUCT ID. NO.	H DIM	X DIM	NAILER COVERAGE
<input type="checkbox"/> FA-S50	5" (127 mm)	3" (76 mm)	1 NAILER
<input type="checkbox"/> FA-S65	6.5" (165 mm)	4.5" (114 mm)	2 NAILERS
<input type="checkbox"/> FA-S80	8" (203 mm)	6" (152mm)	3 NAILERS

Fabrication will proceed only after receipt of signed print approval.

Print Approval:

Architect and/or contractor shall verify all dimensions, sizes and quantities. All products to be installed in strict accordance with Dow Roofing Systems' printed instructions.

Approved by: _____

Date: _____

QUANTITIES:

- _____ Lineal Feet (12'-0" (3.65 m) Lengths)
- _____ Outside Miters @ (____°)
- _____ Inside Miters @ (____°)
- _____ Overflow Scupper Style ___A___B
- _____ Spillout Scupper Style ___A___B
- _____ Downspout Scupper Style ___A___B
- (____X____) Size
 - A: Tapered 1 1/2" (38 mm) Drop
 - B: Flat

PROJECT:

ARCHITECT:

ROOFING CONTRACTOR:

REPRESENTATIVE/DISTRIBUTOR:

Corporate Offices
Dow Roofing Systems
Nine Sullivan Road
Holyoke, MA 01040
P: 800-621-ROOF



ROOFING SYSTEMS

DATE: 03/02/12

DRN BY: JJC

CKD BY: SAK

SHT.# ___ OF ___

DWG# 12010-2983

E