



PRESTO-TITE CANTED FASCIA

GALVANIZED WATERDAM VERSION

INSTALLATION INSTRUCTIONS

SINGLE-PLY APPLICATION

1. WATERDAM & LEVELER

POSITION LEVELER 2" FROM END OF WATERDAM, HOOKING ONTO WATERDAM AND ROTATING INTO PLACE AS SHOWN. DO THE SAME AT THE OTHER END OF 12'-0" LENGTH OF WATERDAM. ALSO PLACE A LEVELER IN CENTER OF 12'-0" LENGTH (3 LEVELERS PER 12'-0" LONG WATERDAM). DO THE SAME FOR MITERS, 2" FROM END OF WATERDAM (2 LEVELERS PER MITER).

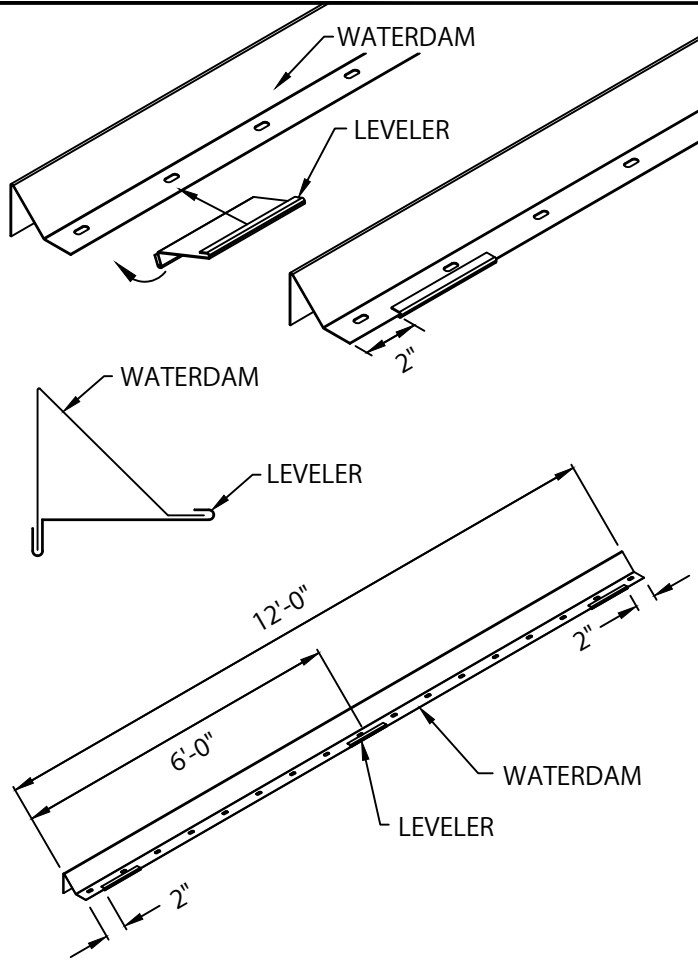

2. WATERDAM

LOCATE AND INSTALL WATERDAM MITERS, NAILING THROUGH PRE-SLOTTED FASTENING HOLES ON TOP OF NAILER(S). DETERMINE AND IDENTIFY LOCATIONS OF SCUPPERS AT THIS TIME. LEAVE GAP OF 14 $\frac{1}{2}$ " FOR SCUPPER LOCATIONS. NEXT, INSTALL 12'-0" SECTIONS OF WATERDAM FROM RIGHT TO LEFT (AS SEEN FROM ROOF TOP) BY NAILING THROUGH PRE-PUNCHED HOLES PROVIDED ON TOP OF NAILER(S). BE SURE TO OVERLAP WATERDAM 1".

NOTE: PROVIDED WATERDAM FASTENER: 1 $\frac{1}{4}$ " RING SHANK GALVANIZED ROOFING NAILS.

CAUTION : INSTALLERS SHALL WEAR PROTECTIVE EYEWEAR TO PREVENT SERIOUS INJURY.

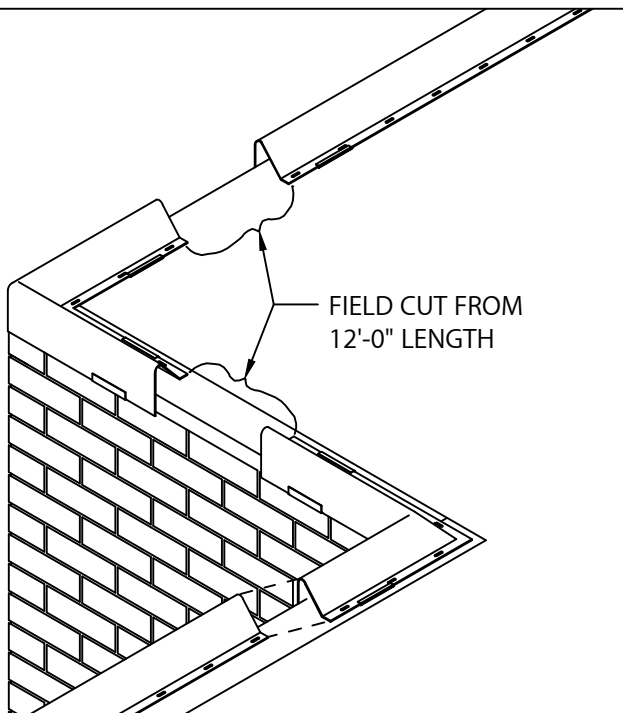



PRESTO-TITE CANTED FASCIA

GALVANIZED WATERDAM VERSION

INSTALLATION INSTRUCTIONS

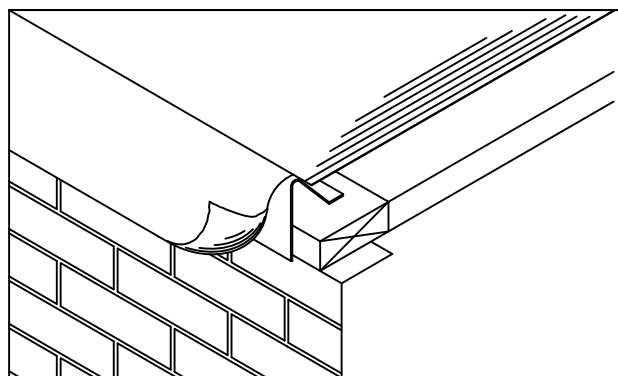

SINGLE-PLY APPLICATION (CONTINUED)

3. ROOFING MEMBRANE

FOLLOW GENERAL RECOMMENDATIONS OF THE ROOF MEMBRANE MANUFACTURERS APPLICATION OF MATERIALS OVER THE ROOF EDGE.

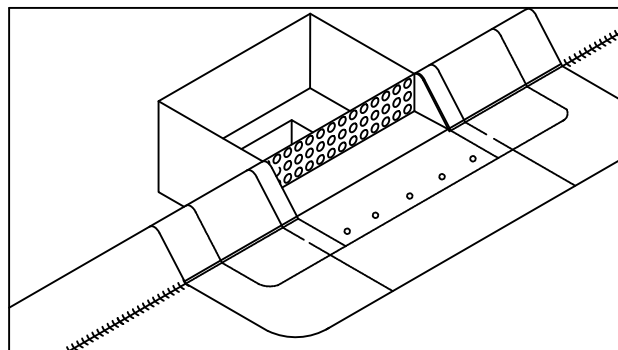

4. SCUPPERS

INSTALL SPILLOUT OR DOWNSPOUT SCUPPERS (IF APPLICABLE) AT PREDETERMINED LOCATIONS.

NOTE : ROOF MEMBRANE IS INSTALLED UNDER SCUPPER. SCUPPER FLANGE IS SET IN A CONTINUOUS BEAD OF NON-CURING SEALANT.

NOTE : FOLLOW GENERAL RECOMMENDATIONS OF THE ROOF MEMBRANE MANUFACTURERS APPLICATION ON STRIPPING IN THE SCUPPER.



PRESTO-TITE CANTED FASCIA

GALVANIZED WATERDAM VERSION

INSTALLATION INSTRUCTIONS

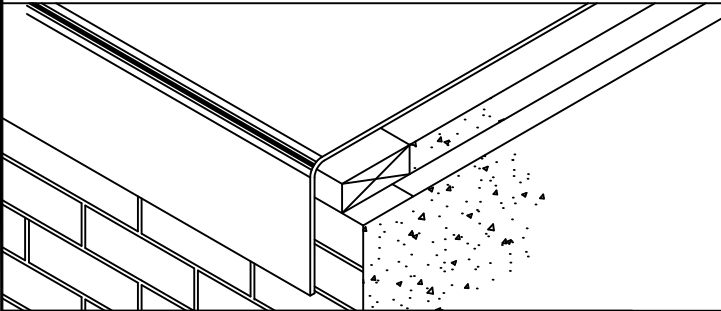

BUILT-UP OR MODIFIED ROOFING

1. BUILT-UP OR MODIFIED ROOFING

POSITION BASE SHEET OF THE BUILT-UP OR MODIFIED ROOFING MEMBRANE OVER THE ROOF EDGE COVERING NAILER(S) COMPLETELY.

NOTE : FOLLOW GENERAL RECOMMENDATIONS OF THE ROOFING MANUFACTURERS APPLICATION OF THE MEMBRANE OVER THE EDGE.

CAUTION : TAKE EXTREME CARE TO AVOID SPILLAGE OF THE ASPHALT OVER THE EDGE.

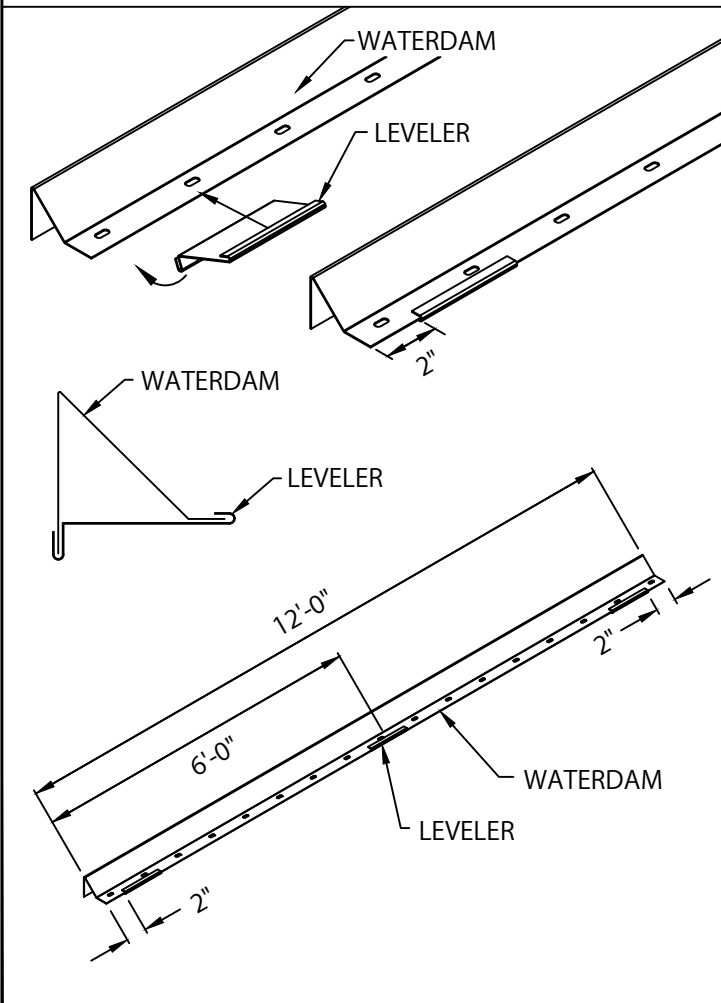

2. WATERDAM & LEVELER

POSITION LEVELER 2" FROM END OF WATERDAM, HOOKING ONTO WATERDAM AND ROTATING INTO PLACE AS SHOWN. DO THE SAME AT THE OTHER END OF 12'-0" LENGTH OF WATERDAM. ALSO PLACE A LEVELER IN CENTER OF 12'-0" LENGTH (3 LEVELERS PER 12'-0" LONG WATERDAM). DO THE SAME FOR MITERS, 2" FROM END OF WATERDAM (2 LEVELERS PER MITER).



PRESTO-TITE CANTED FASCIA

GALVANIZED WATERDAM VERSION

INSTALLATION INSTRUCTIONS

BUILT-UP OR MODIFIED ROOFING (CONTINUED)

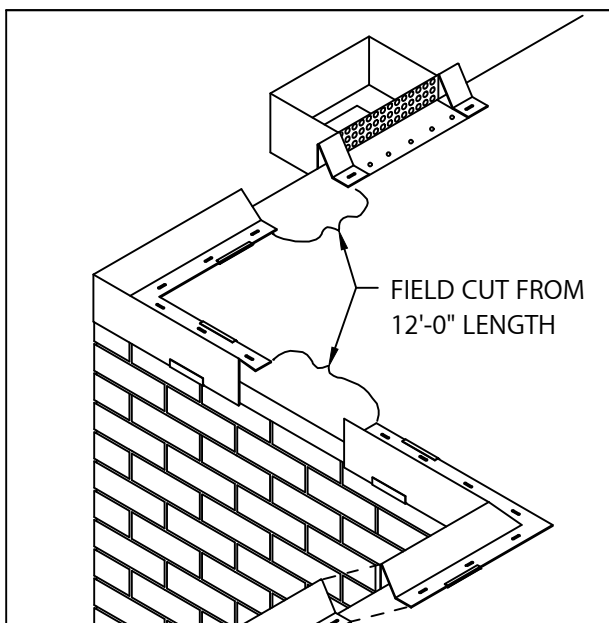

3. WATERDAM

LOCATE AND INSTALL WATERDAM MITERS, AND SCUPPERS FIRST. FASTEN ON TOP OF NAILER THROUGH PRE-PUNCHED HOLES PROVIDED. NEXT, INSTALL 12'-0" SECTIONS OF WATERDAM FROM RIGHT TO LEFT (AS SEEN FROM ROOF TOP) BY NAILING THROUGH PREPUNCHED HOLES PROVIDED ON TOP OF NAILER. BE SURE TO OVERLAP WATERDAM 1".

NOTE: FASTENERS MUST BE CORROSION RESISTANT AND RATED FOR A MINIMUM 250# PULLOUT FORCE FOR THE SUBSTRATE THAT IS BEING USED.

CAUTION: INSTALLERS SHALL WEAR PROTECTIVE EYEWEAR TO PREVENT SERIOUS INJURY.

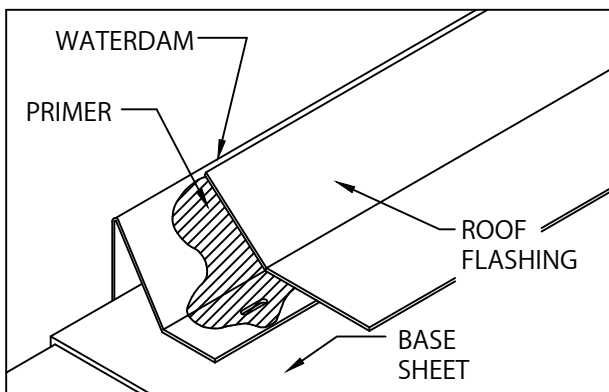

4. ROOF FLASHING

USE APPROPRIATE TYPE AND WIDTH OF ROOF MEMBRANE FLASHING. METAL ASPHALT PRIMER IS NECESSARY TO FLASH UP THE CANT OF THE WATERDAM. CONSULT ROOFING MANUFACTURER FOR PROPER MATERIALS PROCEDURE FOR STRIPPING IN WATERDAM WITH FLASHING.

DIAGONAL SLOT ANCHOR BAR INSTALLATION

NOTE: IF THE SLOTS ON THE ANCHOR BAR ARE ALL HORIZONTAL, NOT DIAGONAL, FASTEN IN THE CENTER OF THE SLOT

PLACE FASTENER AT TOP OF SLOT FOR SINGLE NAILER INSTALLATION

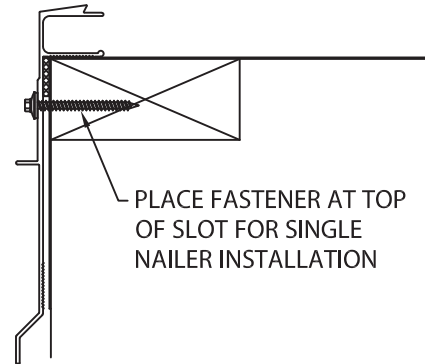

PLACE FASTENER AT BOTTOM OF SLOT IF 1/2" COVER BOARD IS USED

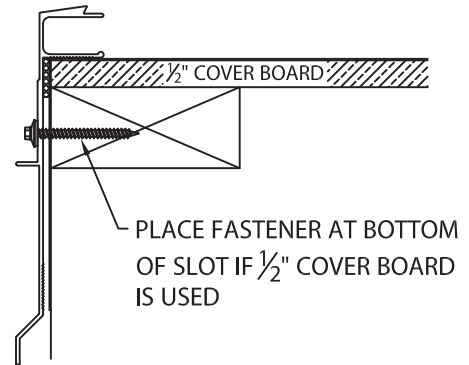

PLACE FASTENER AT BOTTOM OF SLOT IF FASTENING INTO MASONRY

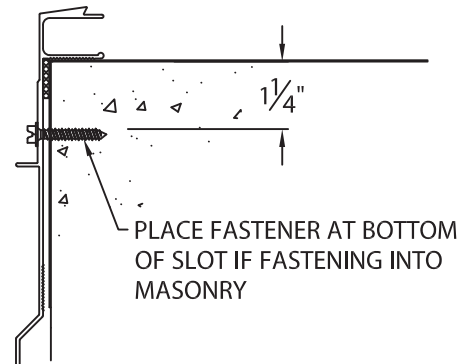

PLACE FASTENER AT BOTTOM OF SLOT IF FASTENING INTO ELIMINAILER-T

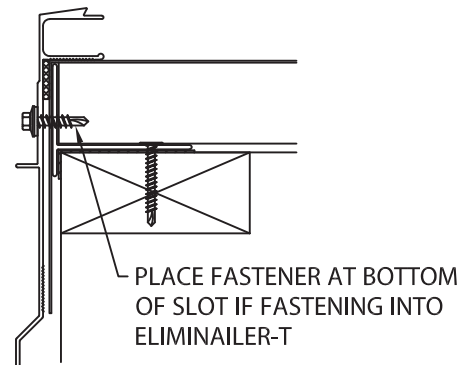



PRESTO-TITE CANTED FASCIA

GALVANIZED WATERDAM VERSION

INSTALLATION INSTRUCTIONS

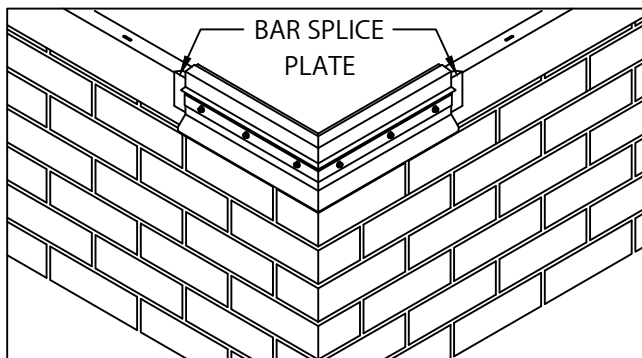

5. MITER BAR INSTALLATION

INSTALL MITER ANCHOR BAR WITH ONE ANCHOR BAR SPLICE PLATE UNDER EACH END OF MITER BAR. FASTEN THE MITER BAR USING 2" HEX HEAD STAINLESS STEEL FASTENERS. FASTENERS AND DRIVE BITS PROVIDED. NEXT LOCATE AND INSTALL THE SPILLOUTS AND SCUPPERS WITH FASTENERS AND SPLICE PLATES.

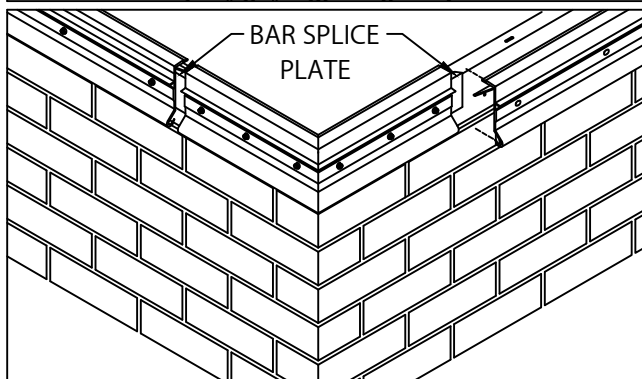

6. ANCHOR BAR INSTALLATION

POSITION 12'-0" ANCHOR BAR SECTIONS OVERLAPPING BAR SPLICE PLATE. ALLOW 3/8" SPACE BETWEEN ANCHOR BARS. INSTALL BAR SPLICE PLATE AT OTHER END OF BAR SECTION. FASTEN ANCHOR BAR 12" O.C. THROUGH THE SLOTTED HOLES USING PROVIDED 2" FASTENERS. FIELD CUT SECTIONS AS IS NECESSARY.

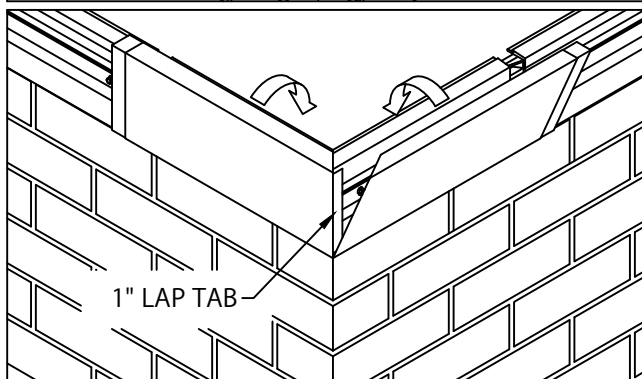

7. FASCIA MITERS COVERS

INSTALL MITER COVERS FIRST. INSERT ONE SPLICE PLATE UNDER EACH END OF THE TWO PIECE MITER COVER. ENGAGE COVER WITH 90° TAB ONTO BOTTOM OF ANCHOR BAR AND ROTATE MITER COVER UP AND OVER ANCHOR BAR MITER UNTIL ENGAGED ALONG ENTIRE LENGTH OF THE ANCHOR BAR. REPEAT STEPS TO INSTALL MITER COVER WITHOUT THE 90° TAB.

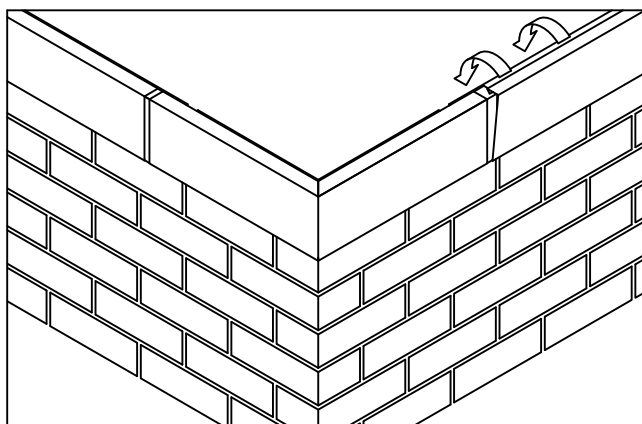

8. FASCIA COVERS

INSTALL 12'-0" FASCIA COVER SECTIONS. ALLOW A 3/8" GAP BETWEEN FASCIA COVER SECTIONS. INSERT ONE SPLICE PLATE UNDER FAR END OF EACH FASCIA COVER SECTION. INSTALL COVER BY HOOKING LOWER EDGE OF COVER ONTO ANCHOR BAR AND ROTATING UP AND OVER ANCHOR BAR UNTIL ENGAGED ALONG ENTIRE LENGTH OF COVER SECTION. CONTINUE TO INSTALL COVER SECTIONS IN THIS MANNER, FIELD CUTTING WHERE NECESSARY USING A FINE TOOTH HACKSAW.

IMPORTANT !

BE SURE TO REMOVE PROTECTIVE FILM PRIOR TO INSTALLING EACH FASCIA SECTION.



PRESTO-TITE CANTED FASCIA

GALVANIZED WATERDAM VERSION

INSTALLATION INSTRUCTIONS

SINGLE-PLY APPLICATION TYPICAL INSTALLATION

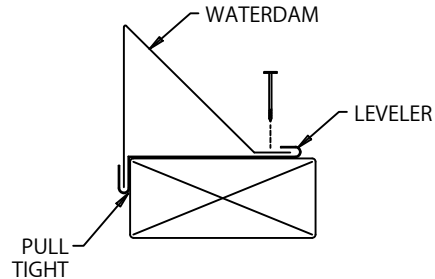
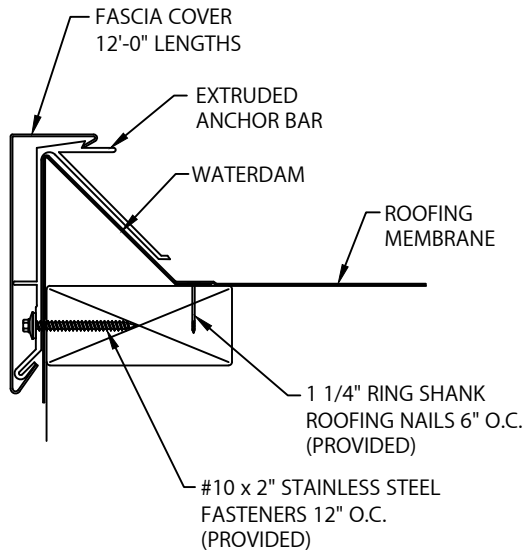

WATERDAM MUST BE PULLED TIGHT TO THE OUTSIDE FACE OF THE BUILDING BEFORE NAILING THE ROOF FLANGE.

B.U.R. / MODIFIED APPLICATION TYPICAL INSTALLATION

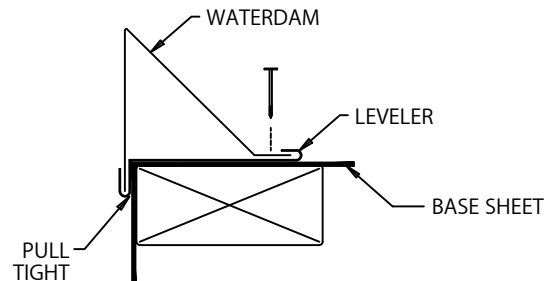
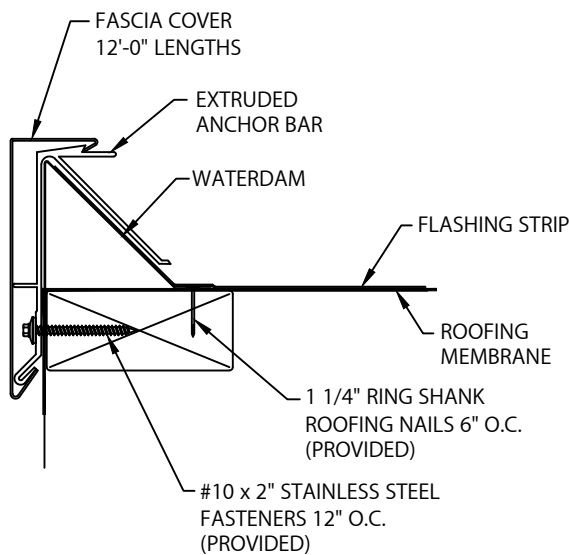

WATERDAM MUST BE PULLED TIGHT TO THE OUTSIDE FACE OF THE BUILDING BEFORE NAILING THE ROOF FLANGE.



PRESTO-TITE CANTED FASCIA

GALVANIZED WATERDAM VERSION

INSTALLATION INSTRUCTIONS

COMPONENT LIST



FASCIA COVER
12'-0" LENGTHS

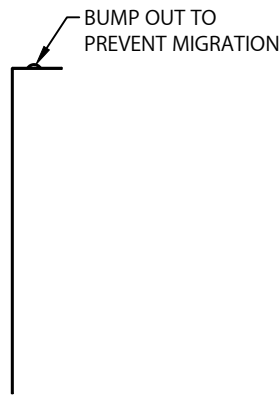

COVER SPLICE PLATE
3 1/2" WIDE

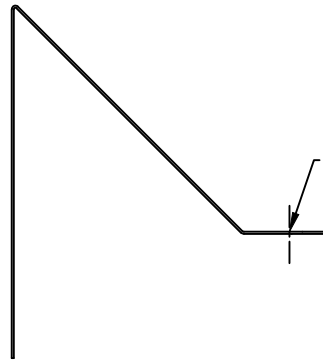

WATERDAM
12'-0" LENGTHS

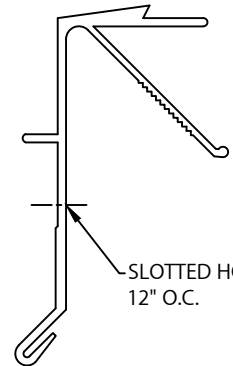

EXTRUDED ANCHOR BAR
12'-0" LENGTHS

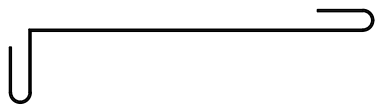

LEVELER
4" WIDE

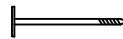

1/4" RING SHANK ROOFING
NAIL FOR INSTALLING
WATERDAM



#10 x 2" STAINLESS STEEL
SCREWS W/WASHER FOR
INSTALLING ANCHOR BAR

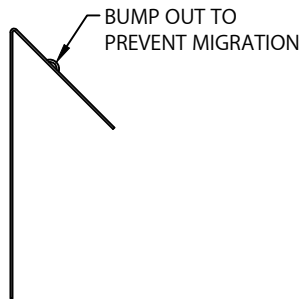

ANCHOR BAR SPLICE
3 1/2" WIDE

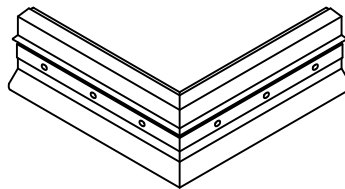

OUTSIDE ANCHOR BAR
MITER

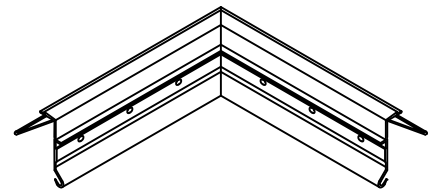

INSIDE ANCHOR BAR
MITER

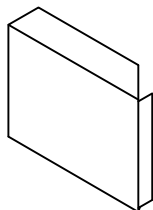

OUTSIDE MITER COVER
WITH TAB

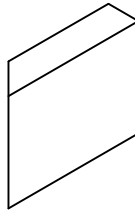

OUTSIDE MITER COVER
WITHOUT TAB

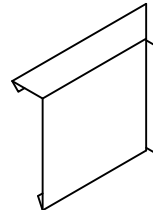

INSIDE MITER COVER
WITH TAB

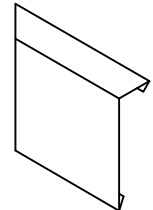

INSIDE MITER COVER
WITHOUT TAB