

1. Roof Membrane

Position Dow Roofing Membrane over the roof edge and down outside face of wall, covering treated wood nailer(s) completely. Allow 1/2" (13 mm) excess membrane.

IMPORTANT! Outside edge of treated wood nailer(s) (min. 2" X 4") shall be aligned flush with or extend slightly past outermost edge of wall.

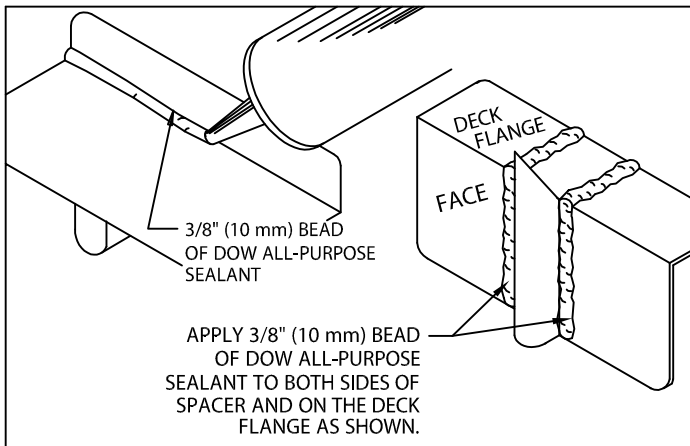

3. Anchor Bar Splice Plates

Apply Dow All-Purpose Sealant to each plate as shown and described in STEP 2.

CAUTION! Installers shall wear protective eye wear to prevent injury. Do not over-drive fasteners, as stripping can occur at high driver torque. Recommended driving tool: 600-800 rpm electric drill equipped with depth-sensing nose-piece to prevent driving and stripout. Do not use impact type tool.

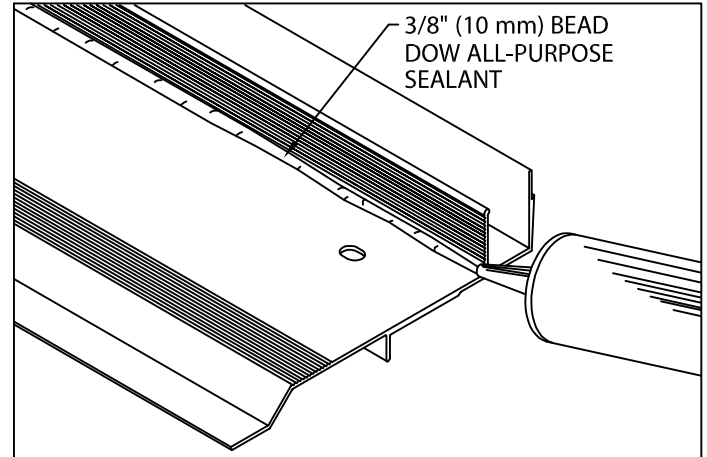

2. Miter & Scupper Anchor Bar (Preparation)

Lay miters and scuppers on deck with outside face down. Be sure aluminum anchor bar is clean and free of dirt or dust. Apply a heavy 3/8" (10 mm) bead of Dow All-Purpose Sealant to the right angle intersection of the deck flange and back of anchor bar as shown. Application of sealant is required along the full length of each miter anchor bar.

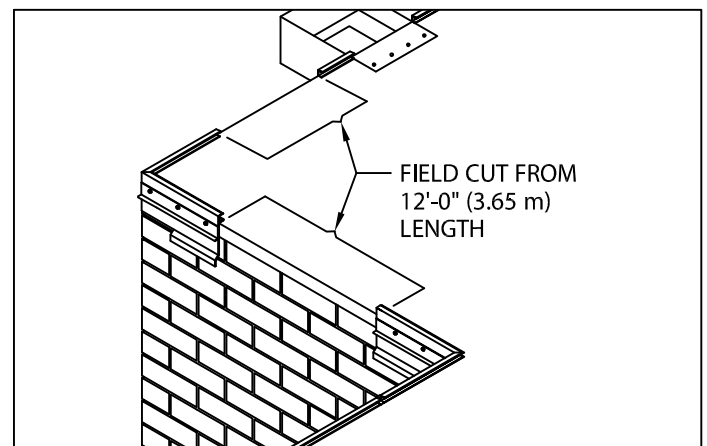

4. Miter Bar Installation

Fold roofing membrane at corners and install miters using 2" (51 mm) hex head stainless steel fasteners and driver bit furnished by Dow Roofing Systems. Fasten anchor bar corners to nailer with one splice plate under each end of corner. The anchor bar splice plate must be snug to ends of anchor bar. Next locate and install spill outs and scuppers with sealant, 2" (51 mm) fasteners and anchor bar splice plates.



DOW HG FASCIA

INSTALLATION INSTRUCTIONS

INSTALLATION INSTRUCTIONS

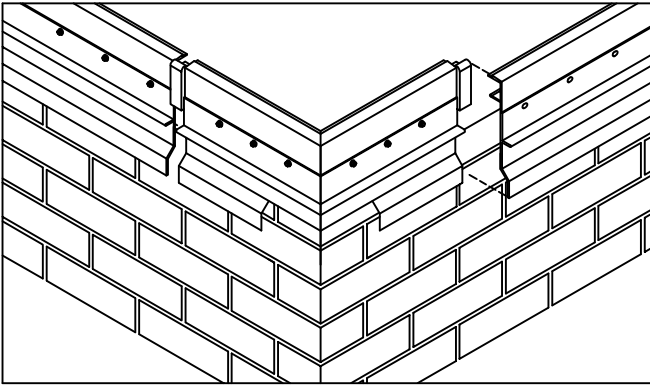

5. Anchor Bar Installation

Position 12' (3.65 m) anchor bar sections with applied Dow All-Purpose Sealant as shown in step 2, overlapping anchor bar splice plate. Allow $\frac{1}{2}$ " (13 mm) space between anchor bars. Install anchor bar splice plate at other end of bar section. Fasten anchor bar 12" (305 mm) O.C. through slotted holes using provided 2" (51 mm) fasteners. Field cut sections as necessary.

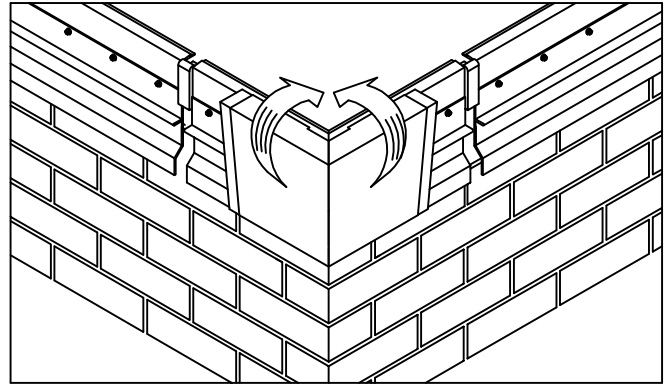

6. Fascia Miter Covers

Install miter covers first. Insert one splice plate under each end of miter cover. Install miter covers by engaging cover onto bottom of anchor bar and rotating miter cover up and over anchor bar miter until engaged along entire length of the anchor bar.

IMPORTANT! Be sure to remove protective plastic film prior to installing each fascia section.

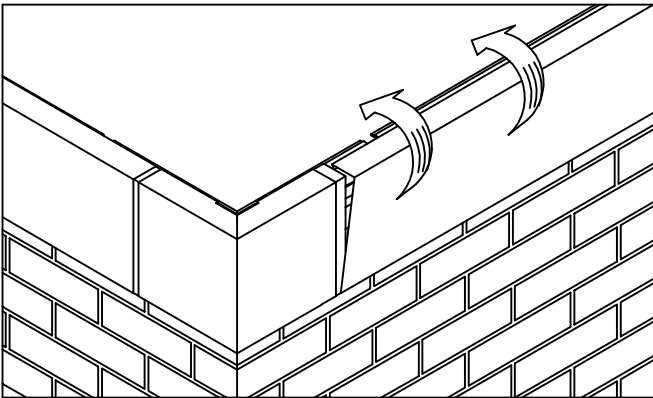

7. Fascia Covers

Install 12'-0" (3.65 m) fascia cover sections. Allow a $\frac{3}{8}$ " (10 mm) gap between fascia cover sections. Insert one splice plate under far end of each fascia cover section. Install cover by hooking lower edge of cover onto anchor bar and rotating cover up and over anchor bar until engaged along entire length of cover section. Continue to install cover sections in this manner, field cutting where necessary using a fine tooth hacksaw.

TYPICAL INSTALLATION

